

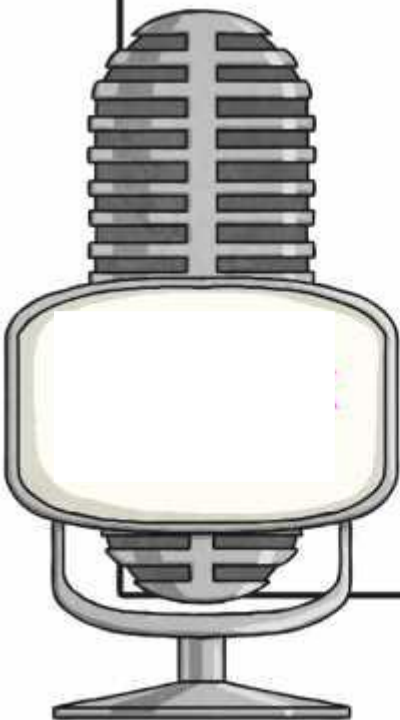

Insert text here



Insert text here



Insert text here



Insert text here

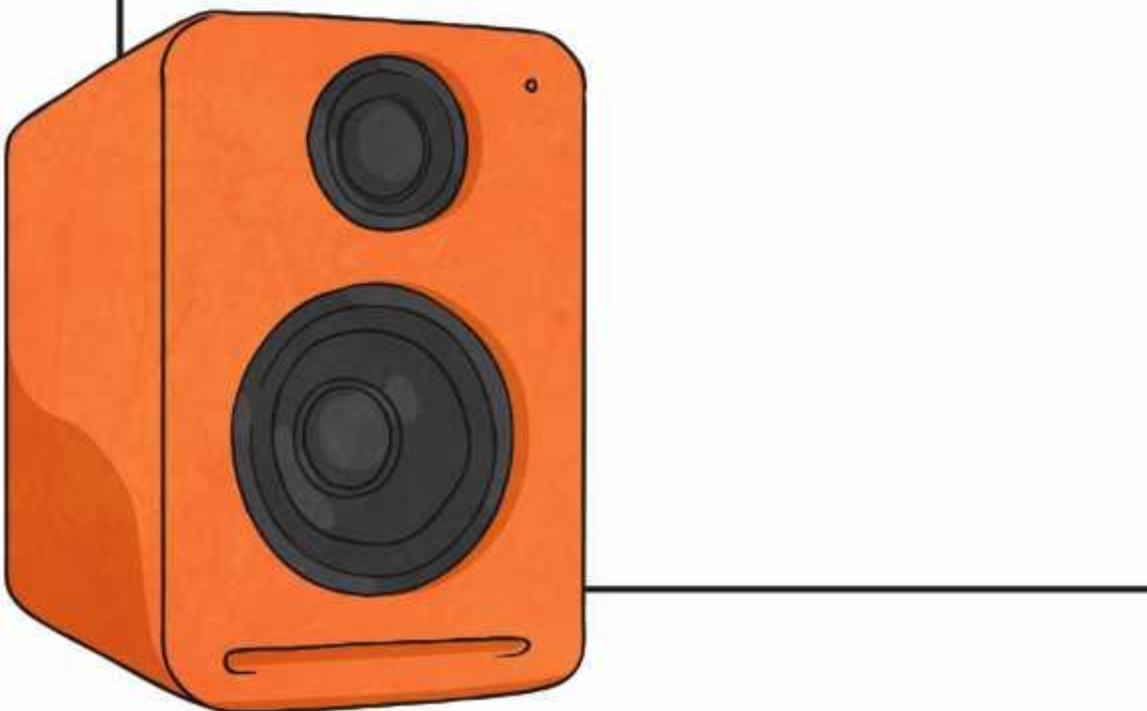

Insert text here

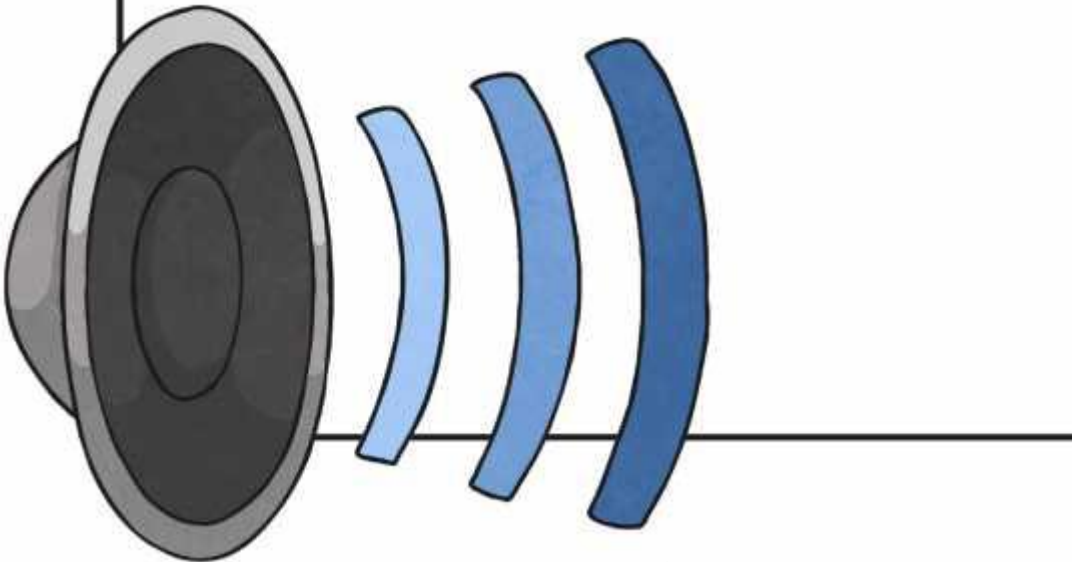

Insert text here



Insert text here



A large rectangular box with a black border, containing several horizontal lines for writing. The lines are positioned in the lower half of the box, starting from the left edge and extending towards the right edge.

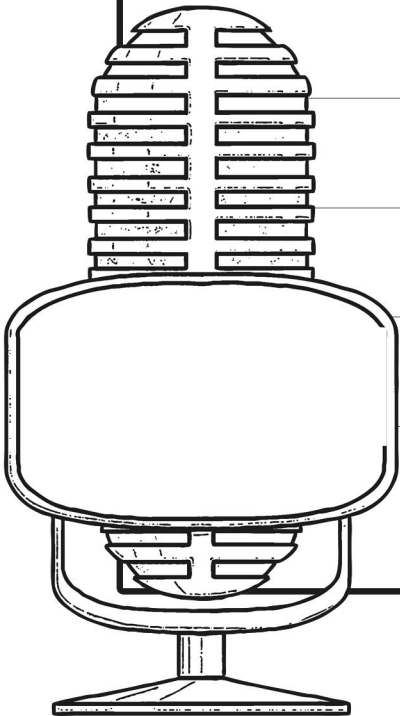

A large rectangular box with a black border, containing several horizontal lines for writing. The lines are evenly spaced and extend across most of the width of the box.

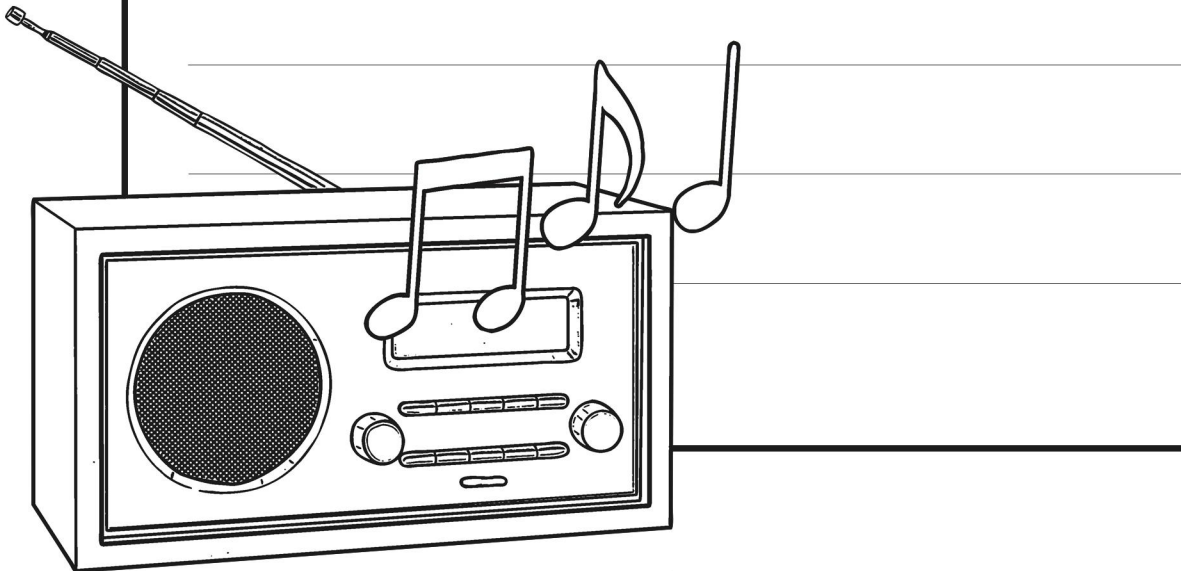

Blank writing area for notes.

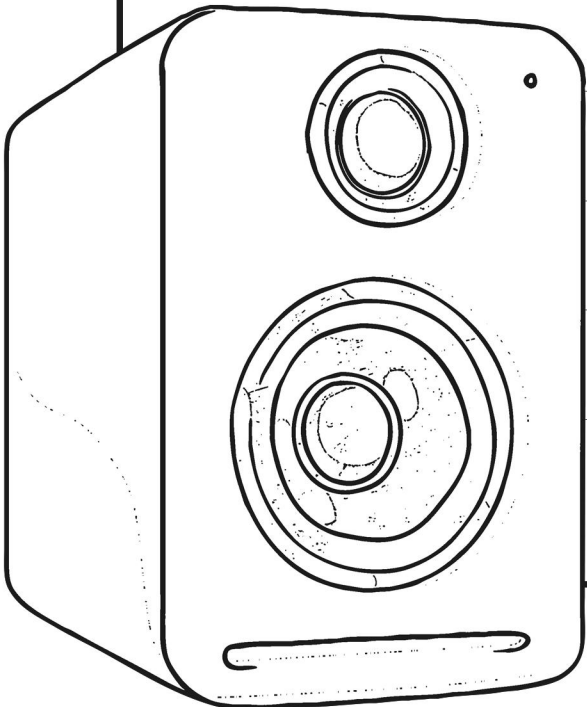

A large rectangular box with a black border, containing four horizontal lines for writing.

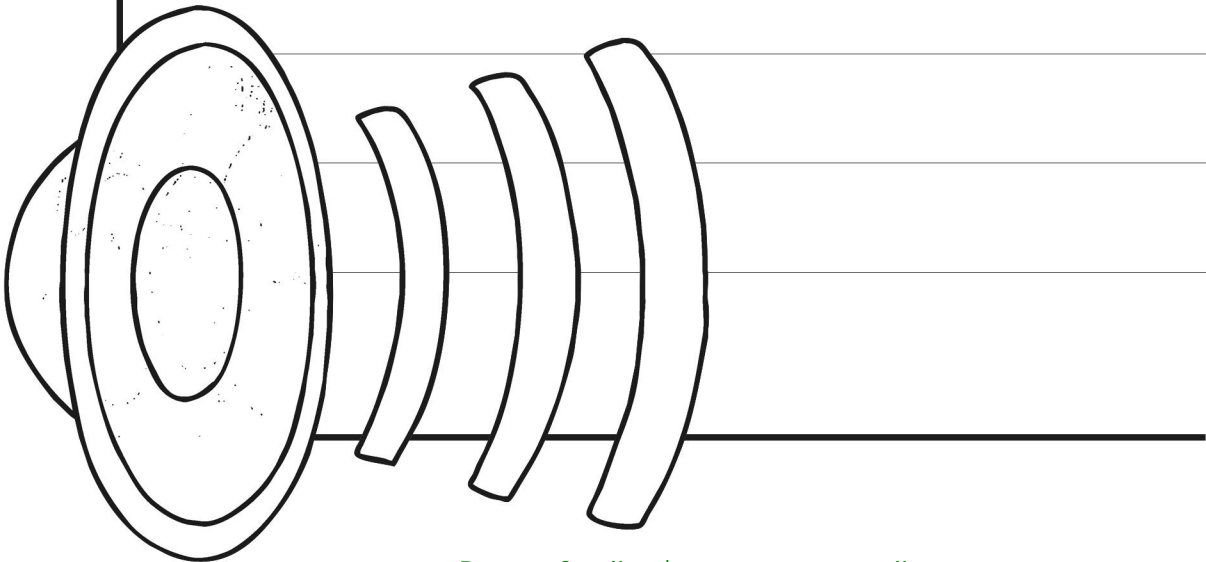

A large rectangular box with a black border, containing a series of horizontal lines for writing. The lines are evenly spaced and extend across most of the width of the box.

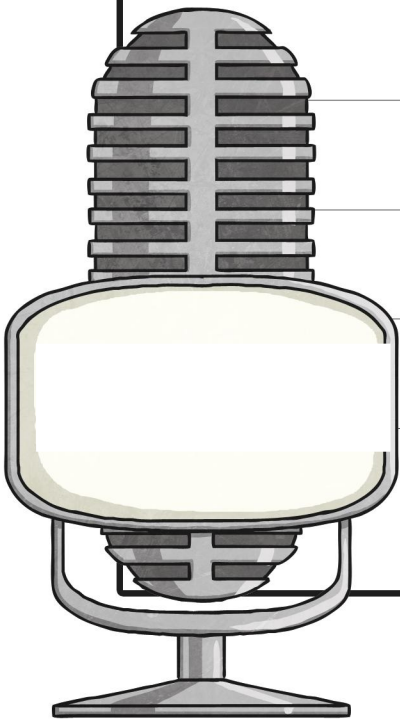

A large rectangular frame containing seven horizontal lines for writing.

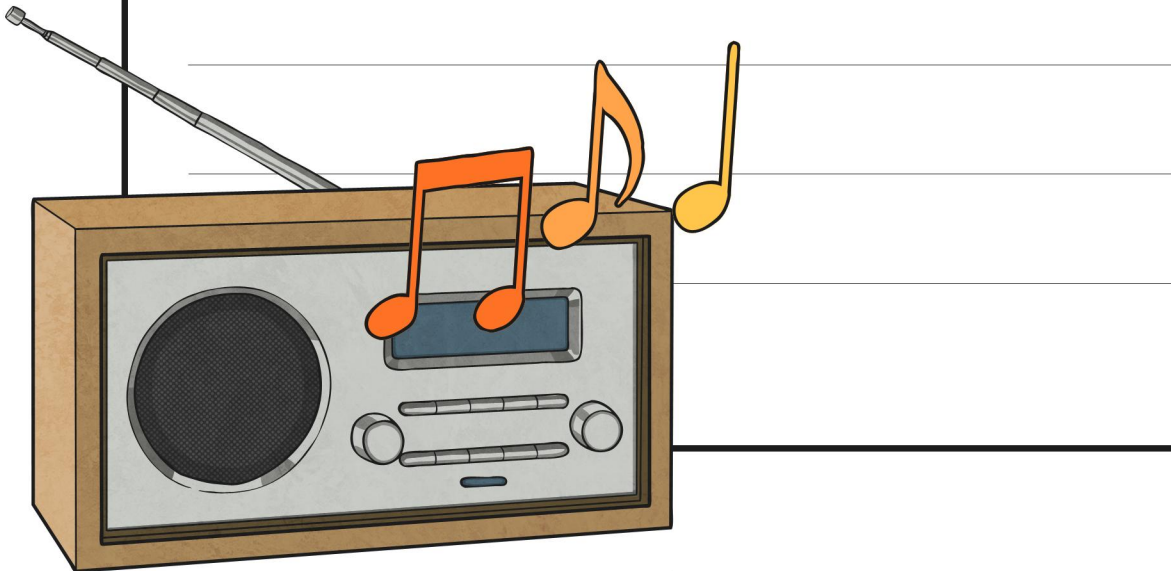



A large rectangular box with a black border, containing four horizontal lines for writing.

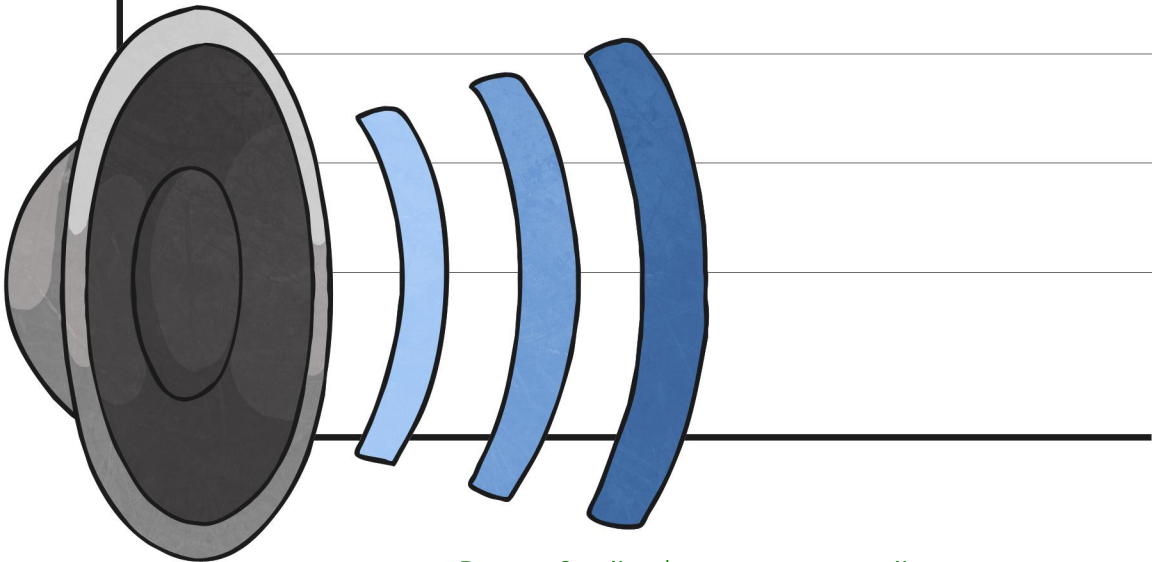

A large rectangular frame containing seven horizontal lines for writing.







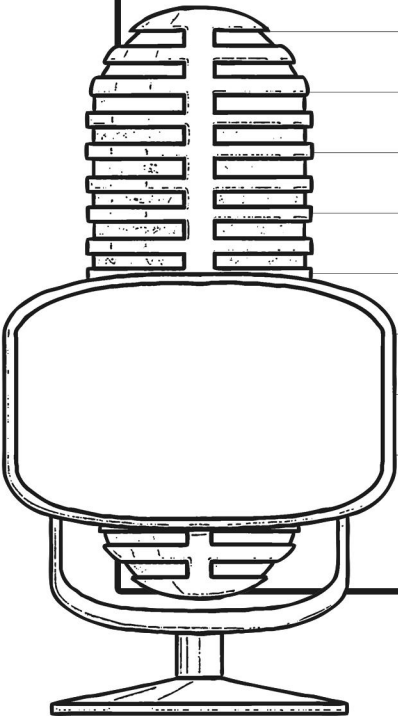

A large rectangular box with a black border, containing ten horizontal lines for writing. The lines are evenly spaced and extend across most of the width of the box.

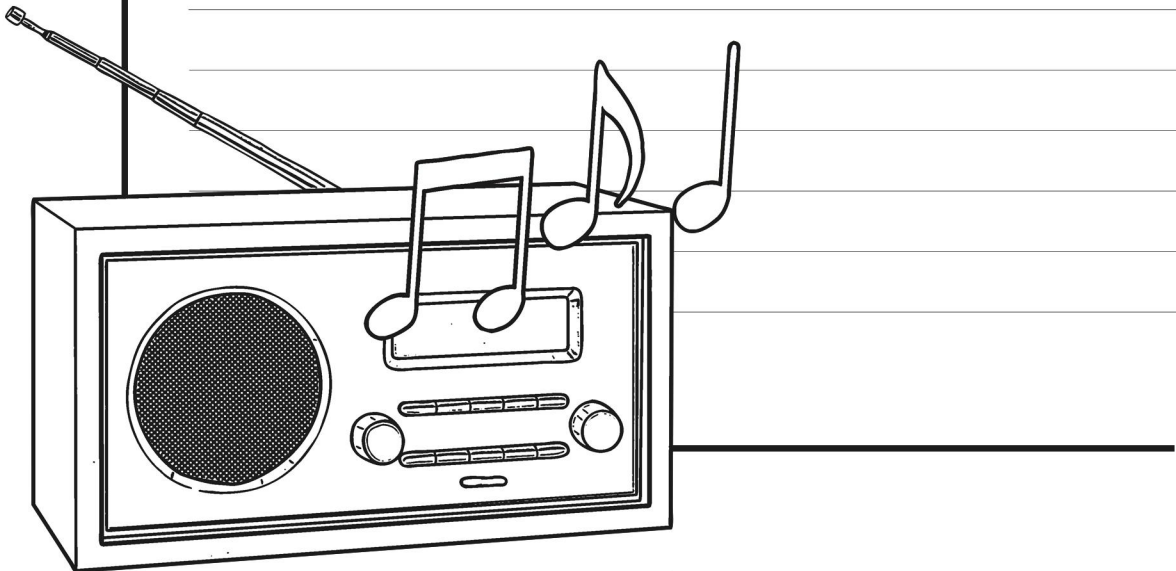

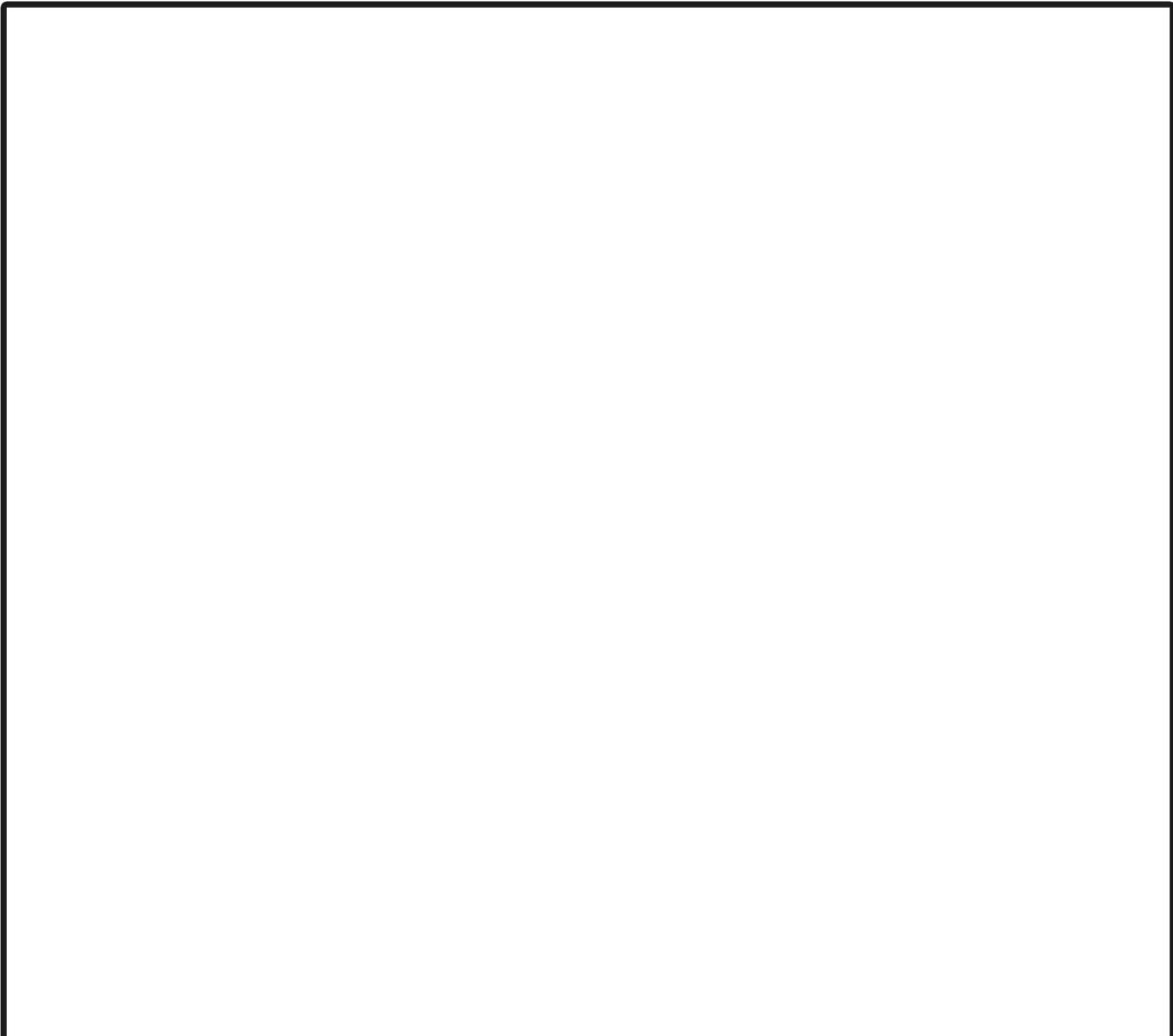

Four horizontal lines for writing, located below the main drawing area.

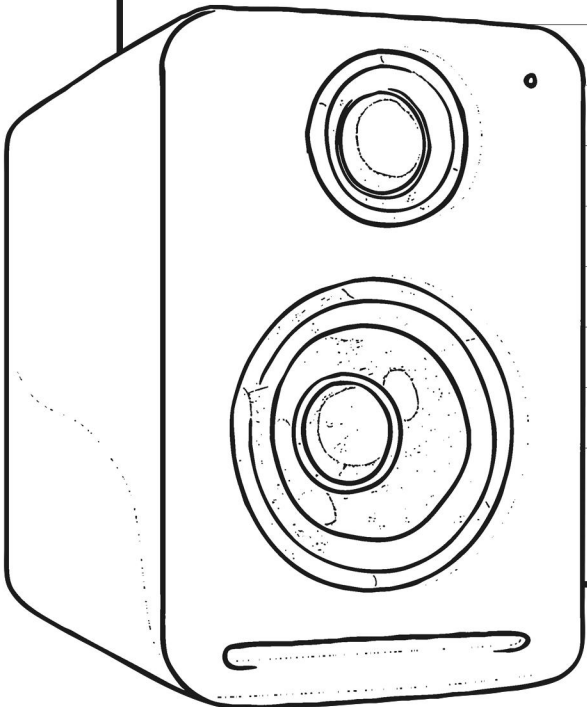

Eight horizontal lines for writing, located to the right of the speaker drawing.

A large rectangular box with a black border, containing a series of horizontal lines for writing.

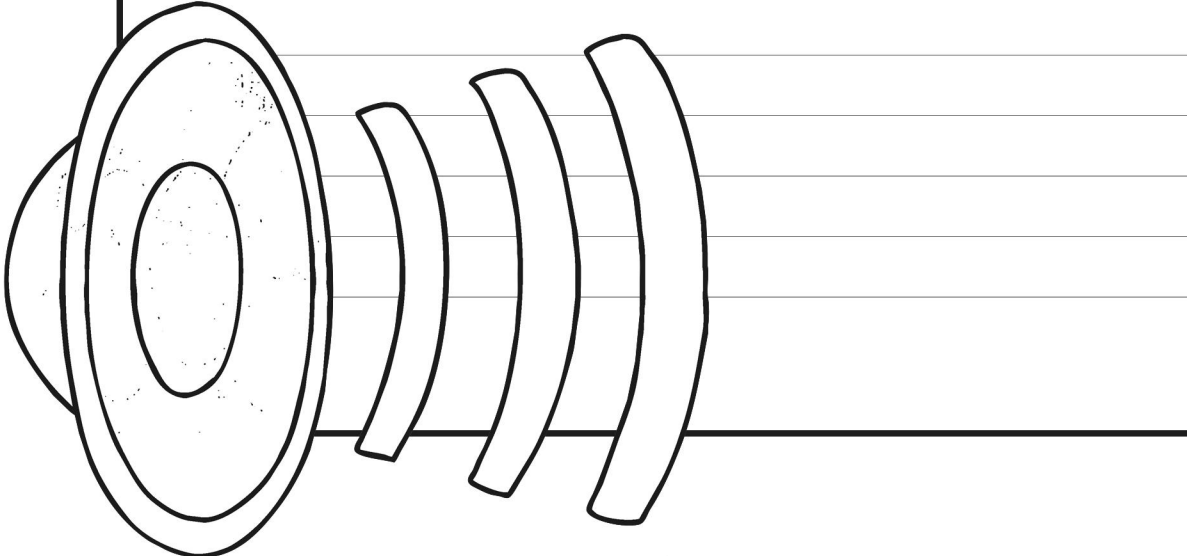

A large rectangular frame containing ten horizontal lines for writing.



A large rectangular frame containing a series of horizontal lines for writing, positioned in the upper and middle sections of the page.



A large rectangular box with a black border, containing a series of horizontal lines for writing. The lines are evenly spaced and extend across most of the width of the box.

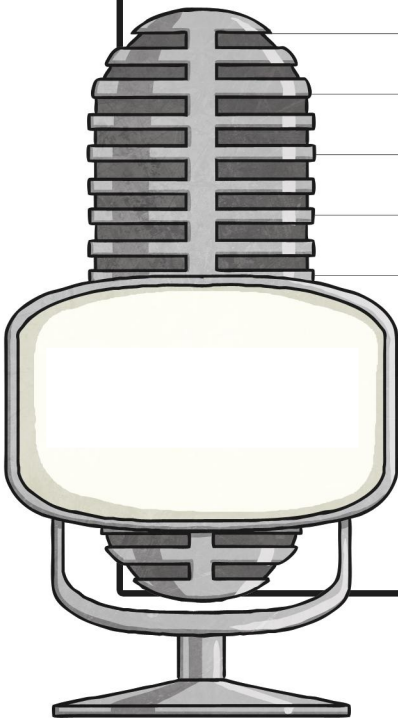

A large rectangular frame containing ten horizontal lines for writing.

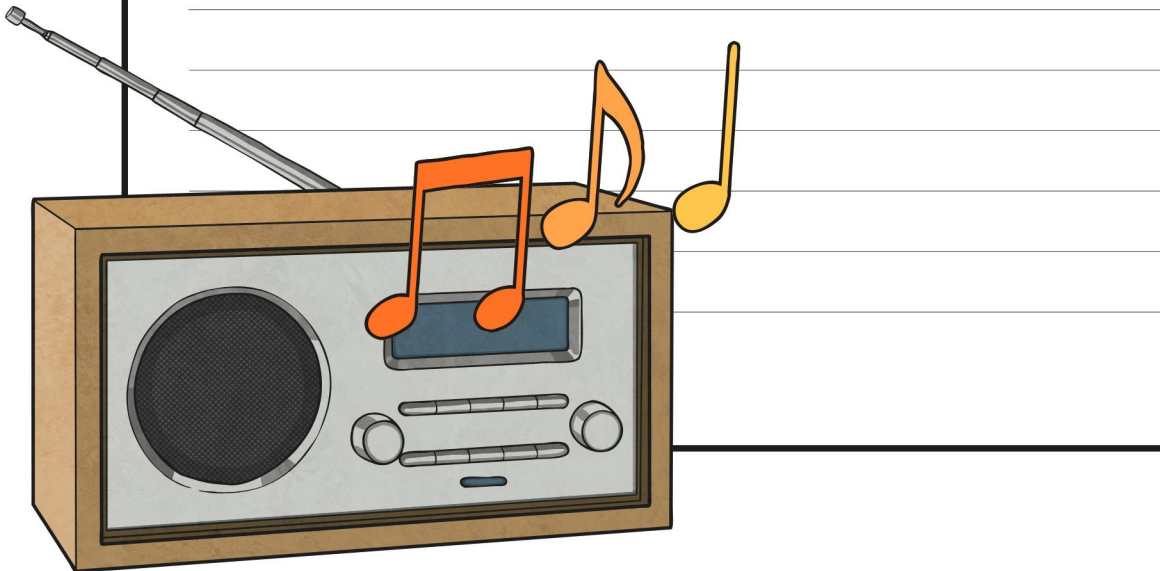

A large rectangular frame containing a series of horizontal lines for writing, positioned in the upper and middle sections of the page.

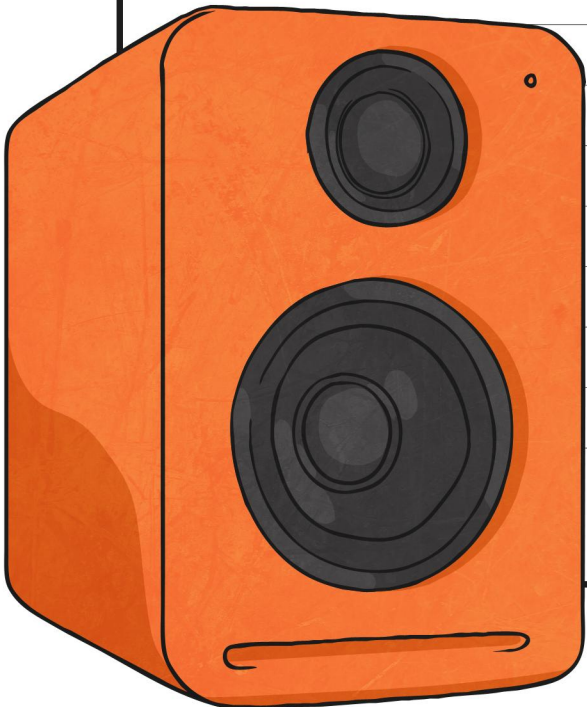

A large rectangular box with a black border, containing several horizontal lines for writing.

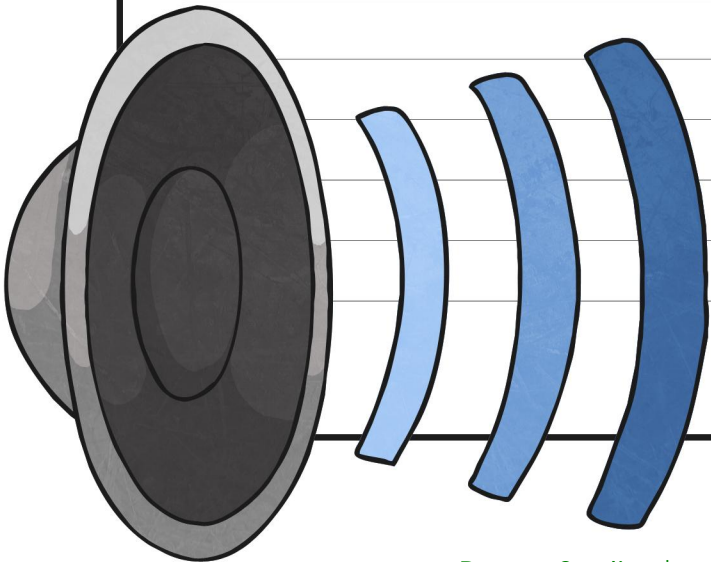

A large rectangular frame containing ten horizontal lines for writing.



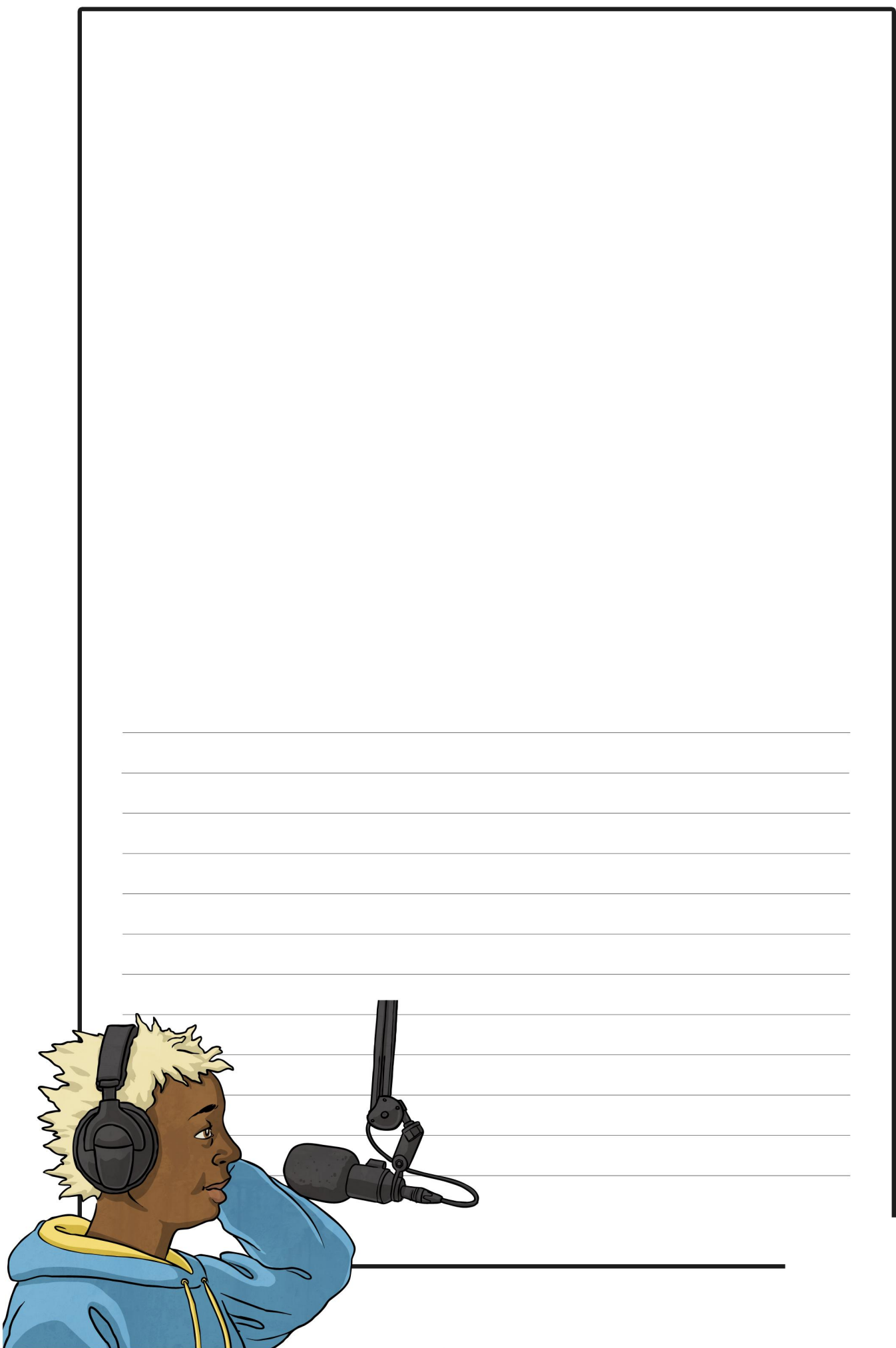

A large rectangular frame containing 15 horizontal lines for writing.

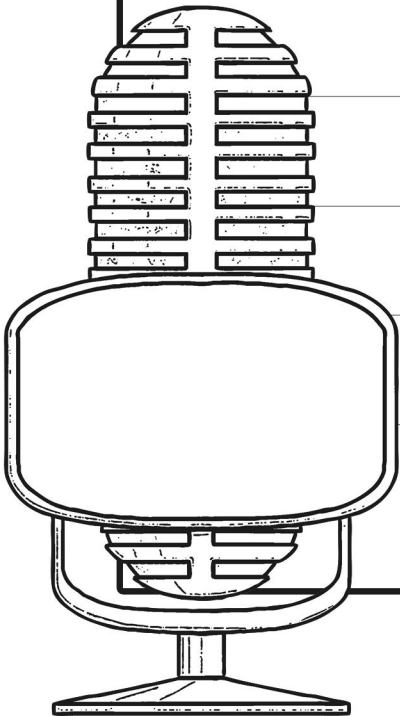

A large rectangular box containing 20 horizontal lines for writing.

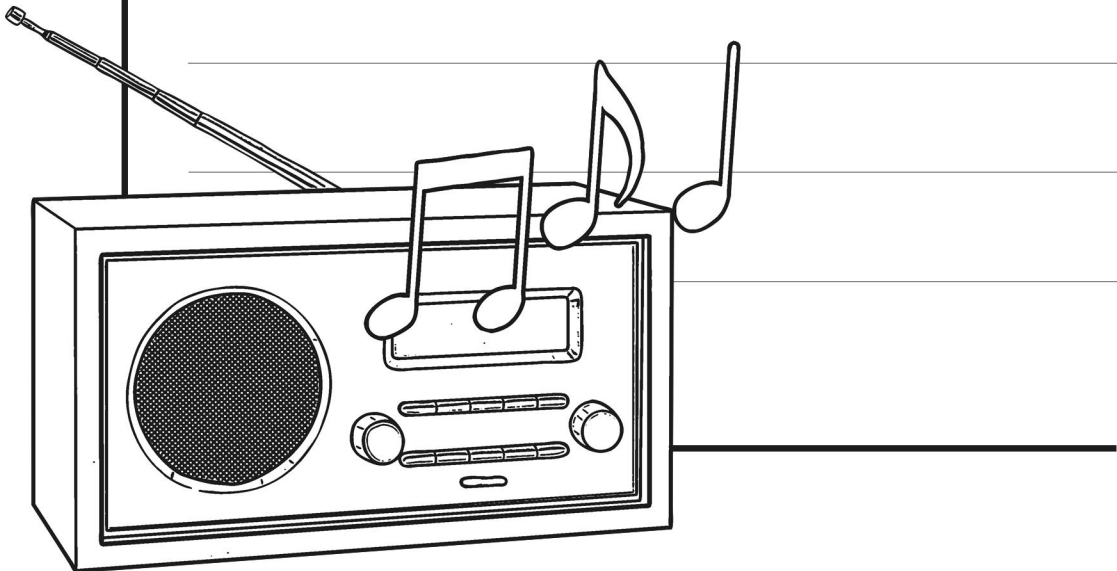

Lined writing area for notes.

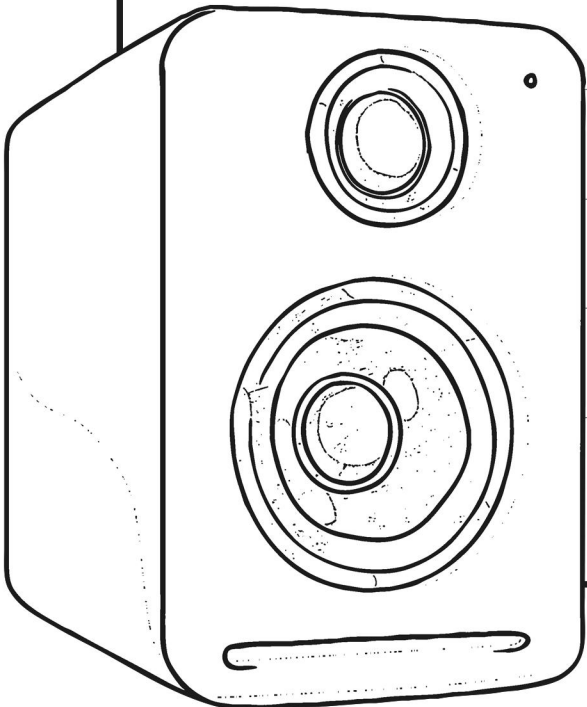

Lined writing area with 15 horizontal lines.

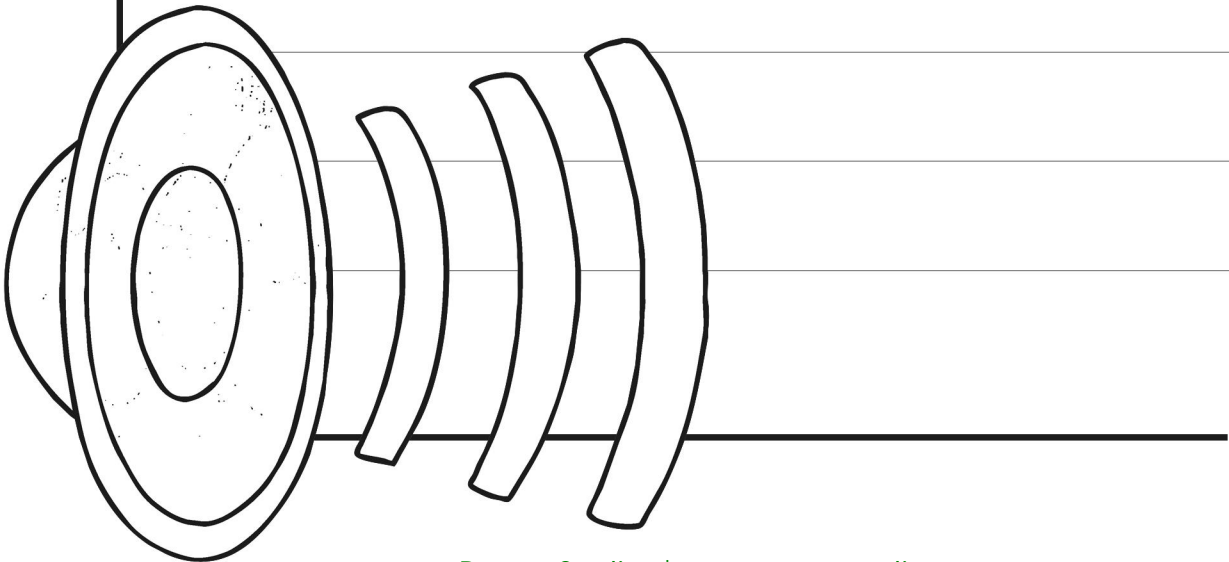

Lined writing area with 18 horizontal lines.

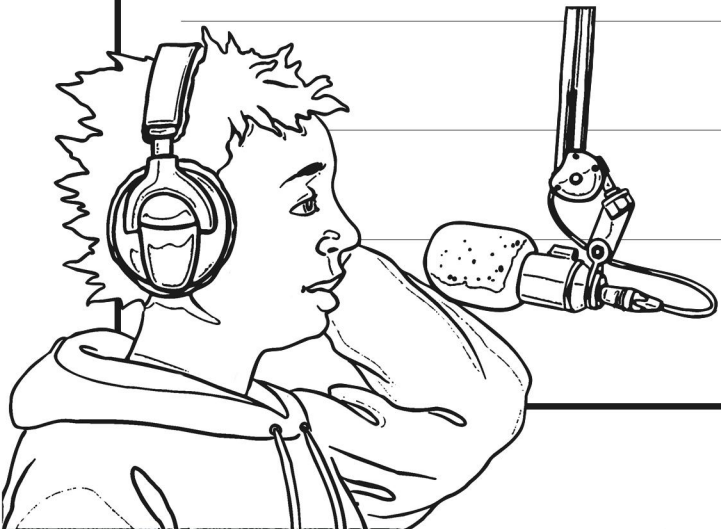

A large rectangular box containing 15 horizontal lines for writing.

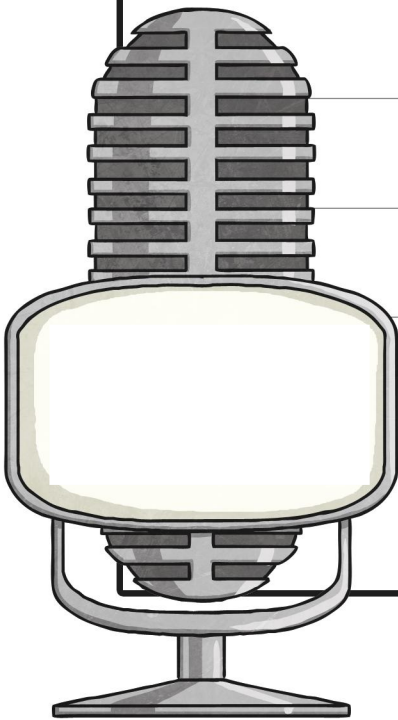

A large rectangular area with a black border, containing 20 horizontal lines for writing.

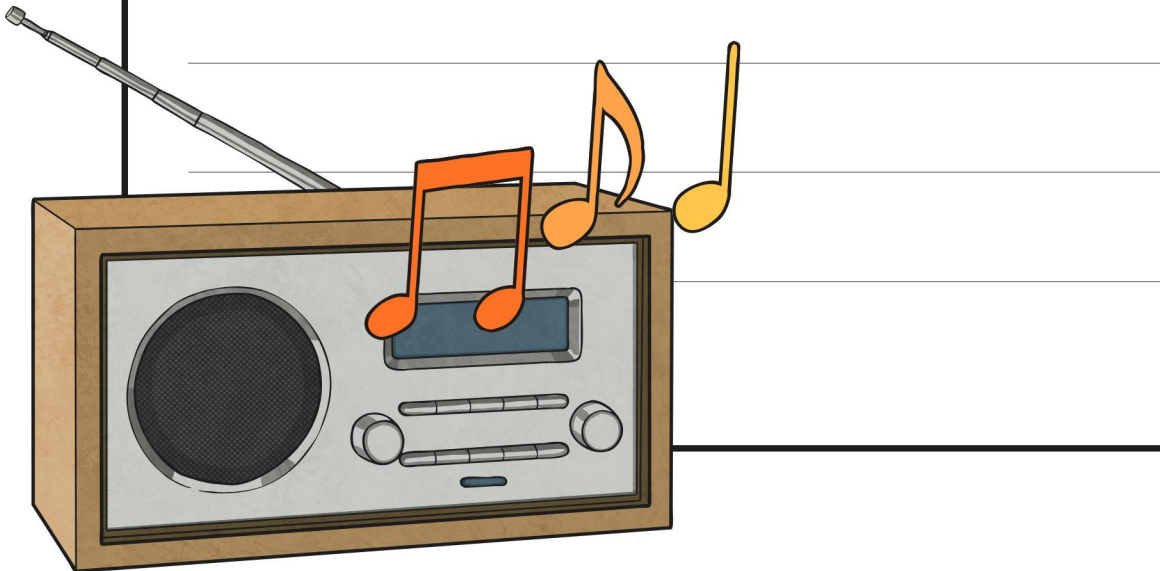

A large rectangular area with a black border, containing 15 horizontal lines for writing.



Lined writing area for notes.

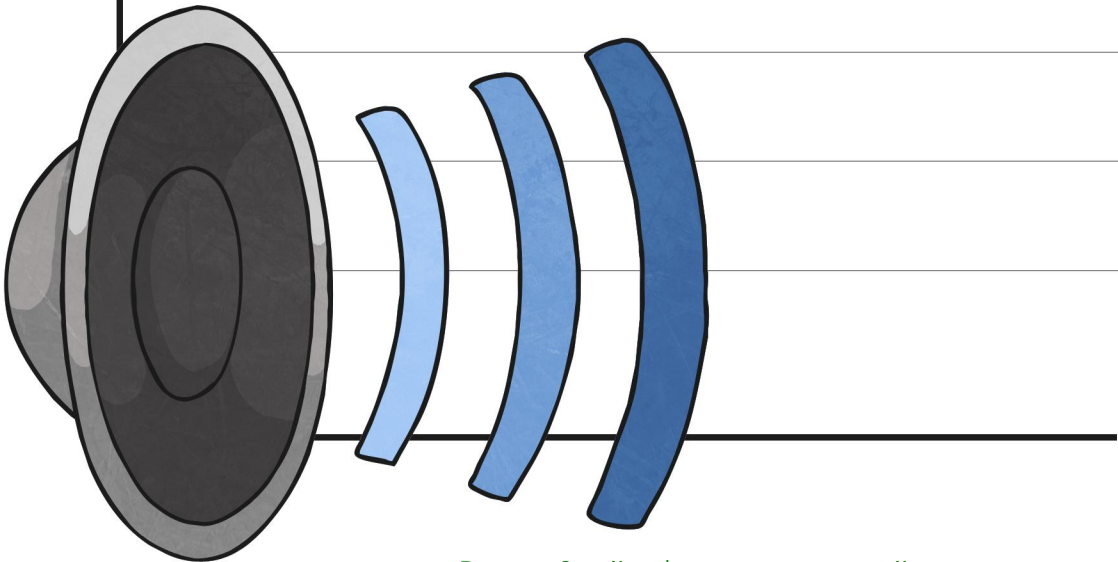

A large rectangular area with a black border, containing 20 horizontal lines for writing.



A large rectangular frame containing 18 horizontal lines for writing.



A large rectangular area with horizontal lines for writing, enclosed in a black border.

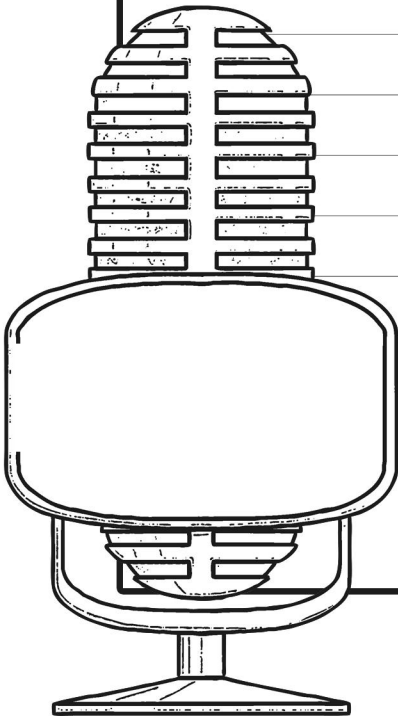

A large rectangular area with horizontal lines, intended for writing or drawing.

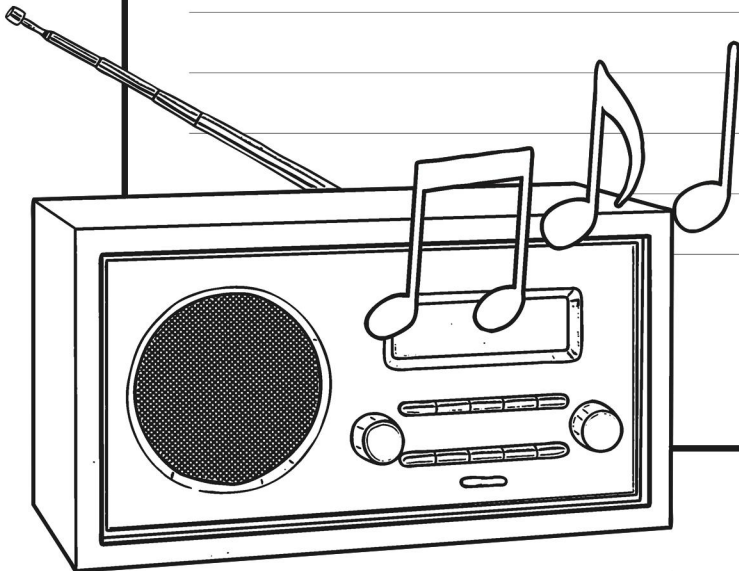

Lined writing area for notes.

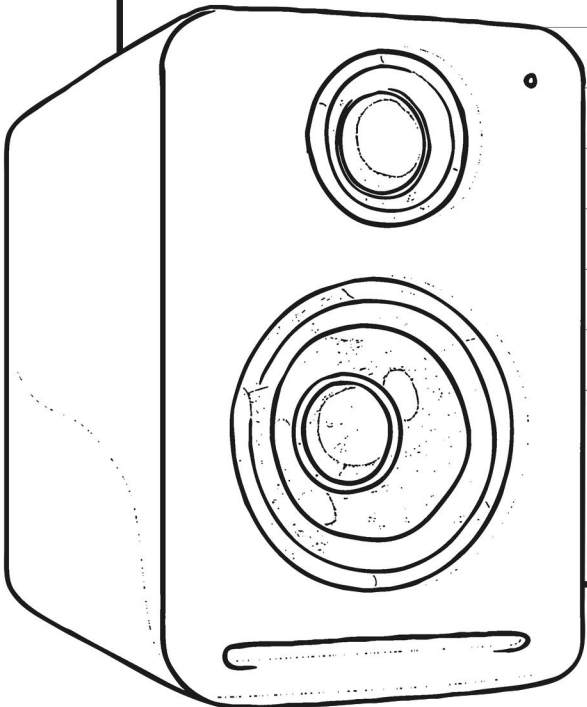

Lined writing area for notes.

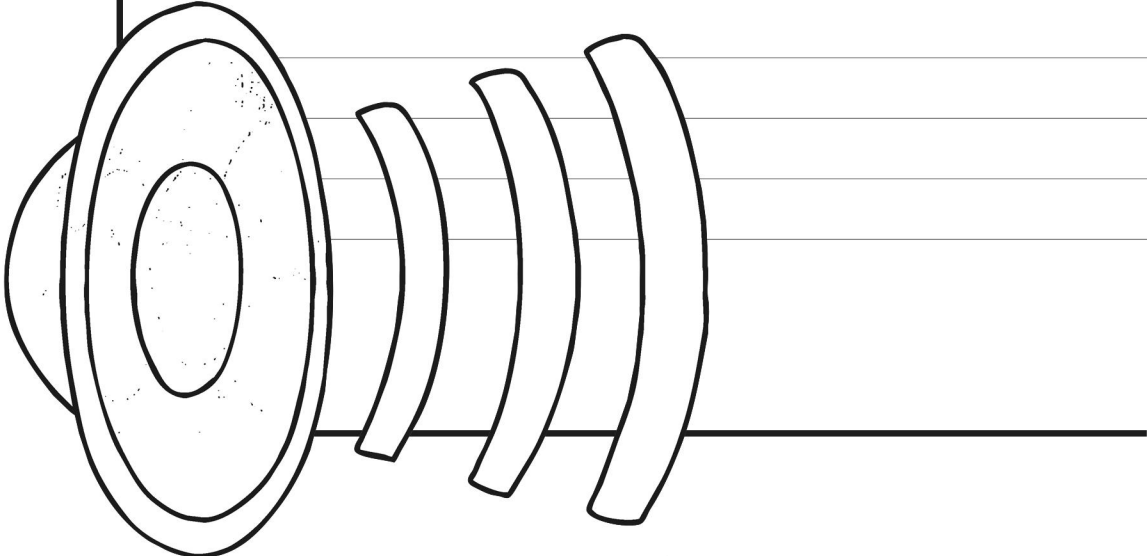

Lined writing area for notes or answers.



Lined writing area for notes.



A large rectangular area with a black border, containing 25 horizontal lines for writing.

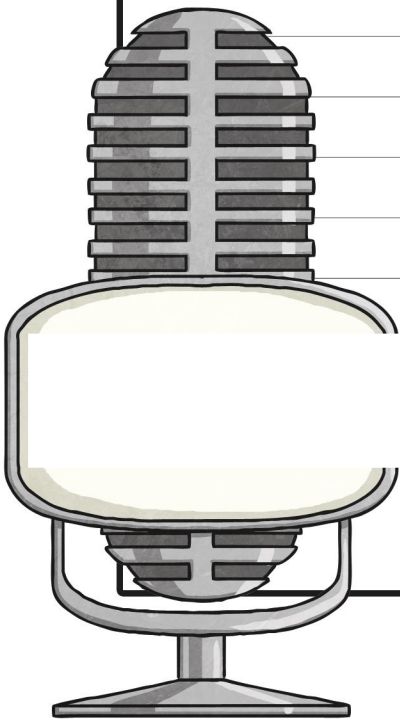

A large rectangular area with horizontal lines, intended for writing lyrics or notes.

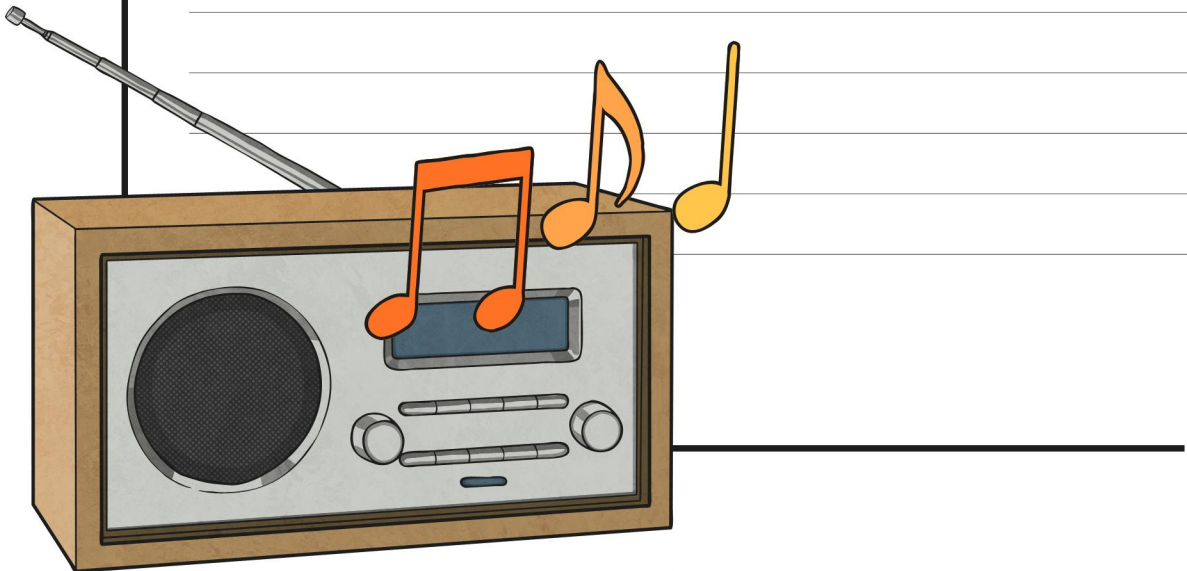

Lined writing area for notes or transcription.



A large rectangular area with a black border, containing 25 horizontal lines for writing.



Lined writing area for notes.

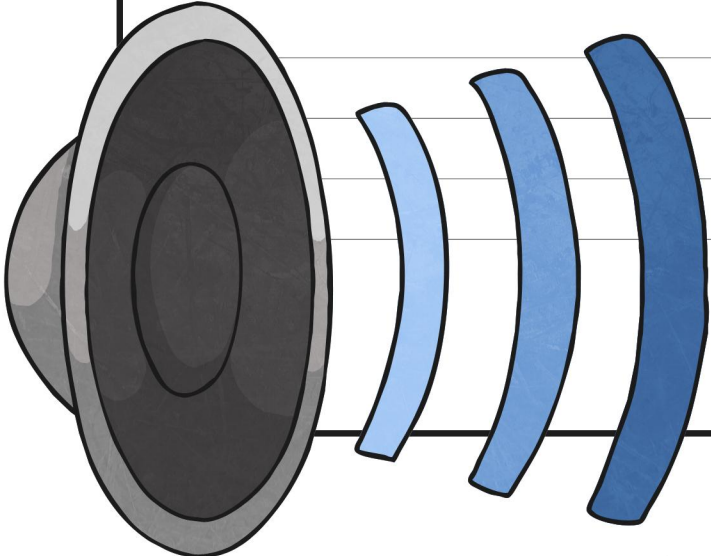

A large rectangular area with a black border, containing 25 horizontal lines for writing.



A large rectangular area with horizontal lines for writing, enclosed in a black border.





Radio Station

Challenge Cards



Radio Station

Challenge Cards

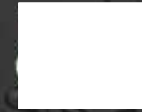

Radio Station

Challenge Cards

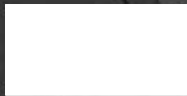

Radio Station

Challenge Cards





Can you use sound effects to record a scary voice for Halloween?



Can you use sound effects to make a voice recording sound like a chipmunk?



Can you use sound effects to make a voice recording sound like it has an echo?

Can you change the tone and pitch of your voice to make your expression more interesting, in the style of a good radio presenter?



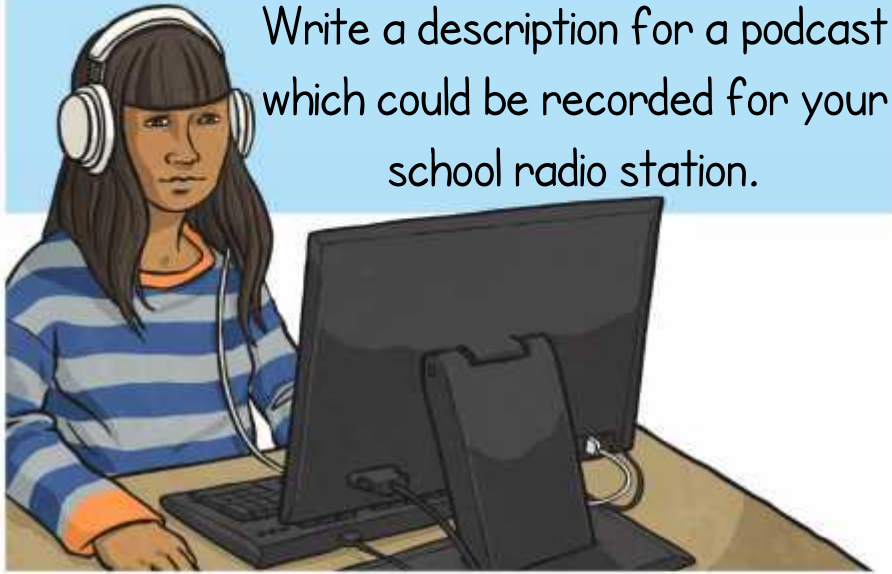

Write a description for a podcast which could be recorded for your school radio station.

Write an advert for a school radio station, persuading people to tune in and listen!



Design or draw a new radio station logo. Think of a name and slogan.



Research and write about a famous radio presenter from a local or national radio station.



Make a glossary/mini-dictionary of technical words related to a radio station or sound recording. Can you write definitions for them?



Write a letter to a radio station or radio DJ telling them about your work. You could ask some questions too!



Practise your interviewing technique with a partner. One person can be the interviewer while the other plays the part of a famous sports person musician or TV star!

Write a script and/or record a news report about something in your local area. It could be serious, funny or just interesting.



Radio Station

Challenge Cards



Radio Station

Challenge Cards



Radio Station

Challenge Cards



Radio Station

Challenge Cards





Can you use sound effects to record a scary voice for Halloween?



Can you use sound effects to make a voice recording sound like a chipmunk?



Can you use sound effects to make a voice recording sound like it has an echo?

Can you change the tone and pitch of your voice to make your expression more interesting, in the style of a good radio presenter?





Write a description for a podcast which could be recorded for your school radio station.

Write an advert for a school radio station, persuading people to tune in and listen!

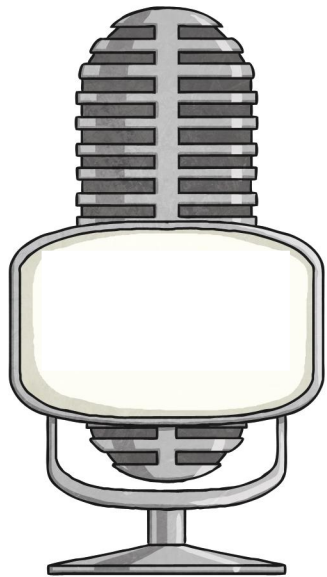
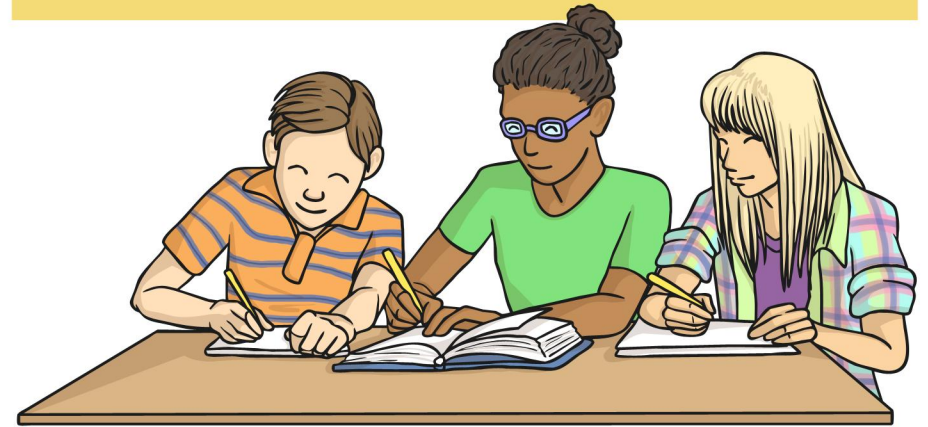

Design or draw a new radio station logo. Think of a name and slogan.



Research and write about a famous radio presenter from a local or national radio station.



Make a glossary/mini-dictionary of technical words related to a radio station or sound recording. Can you write definitions for them?

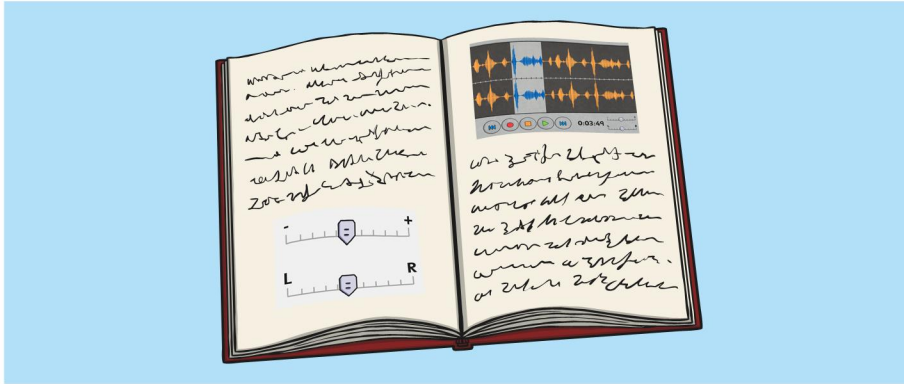

Write a letter to a radio station or radio DJ telling them about your work. You could ask some questions too!



Practise your interviewing technique with a partner. One person can be the interviewer while the other plays the part of a famous sports person musician or TV star!

Write a script and/or record a news report about something in your local area. It could be serious, funny or just interesting.



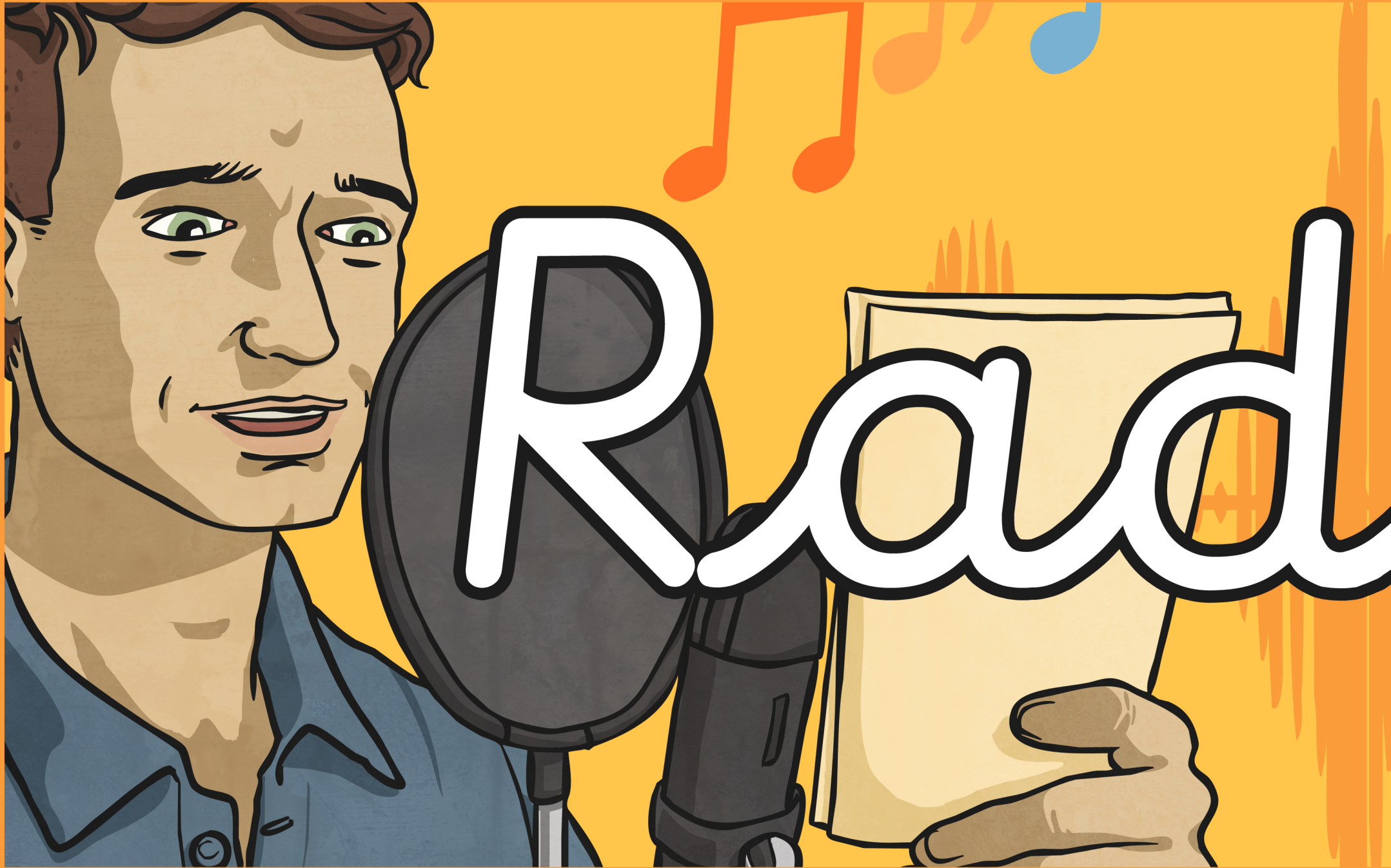

io

Sta







io S tat







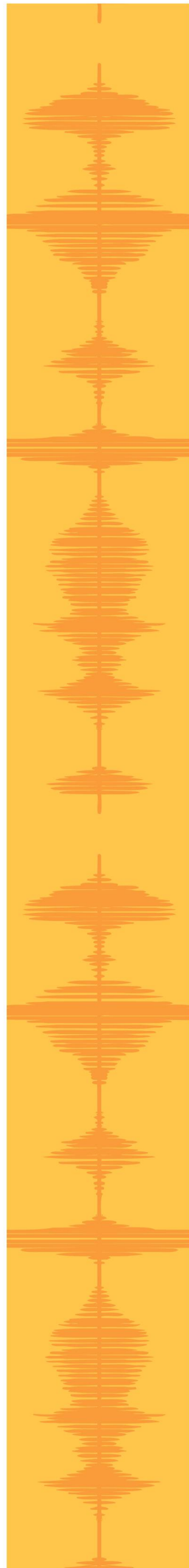
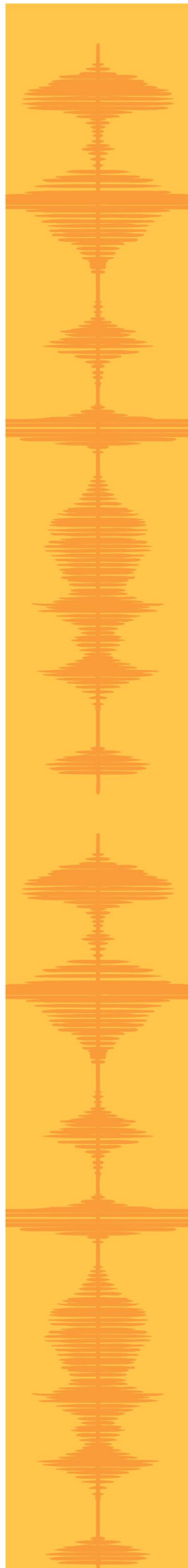
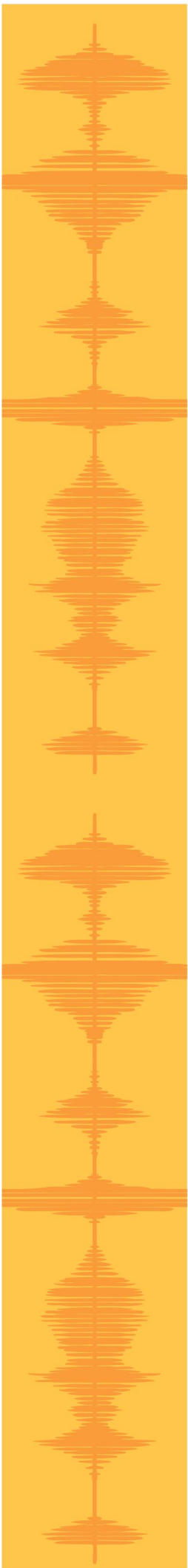

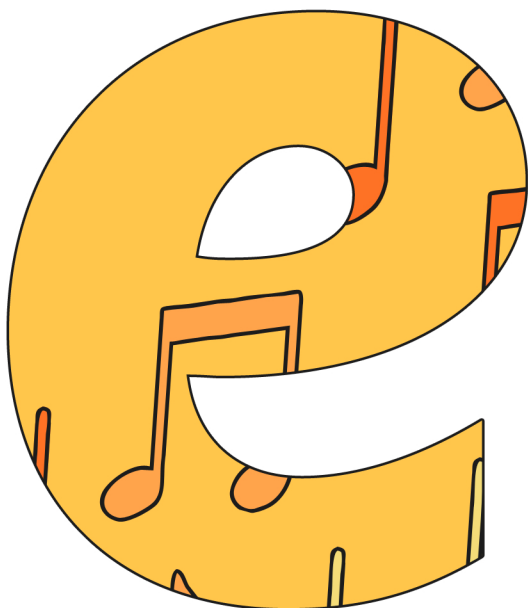
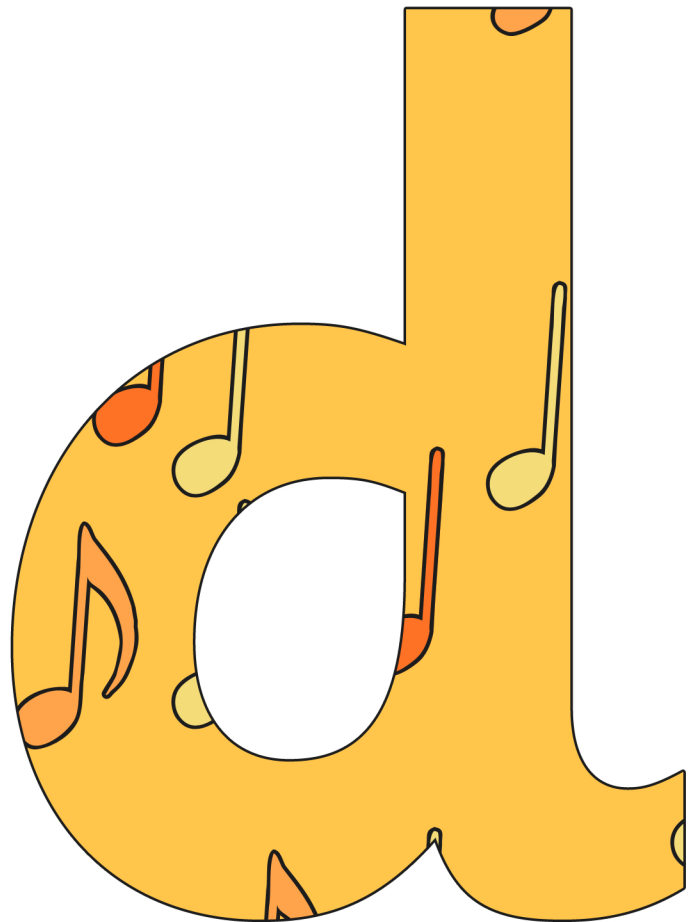
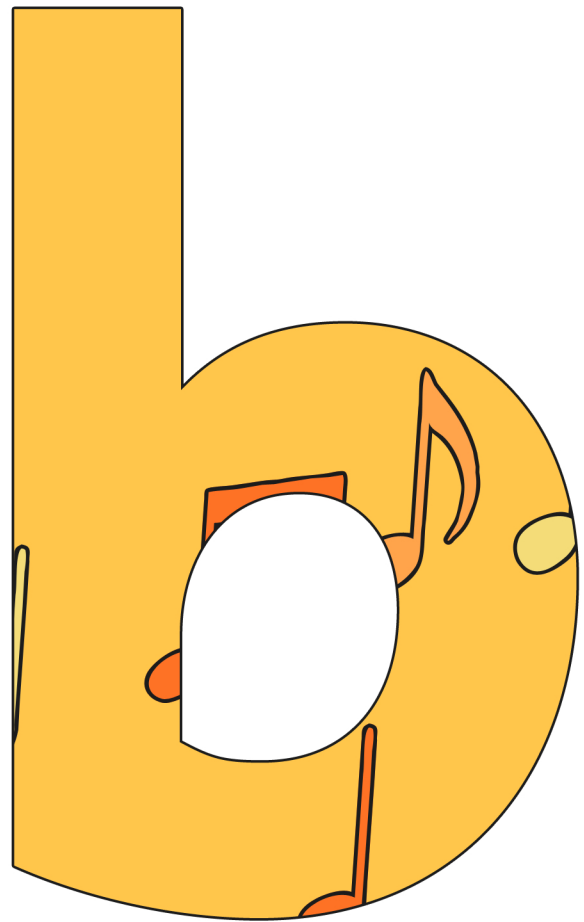

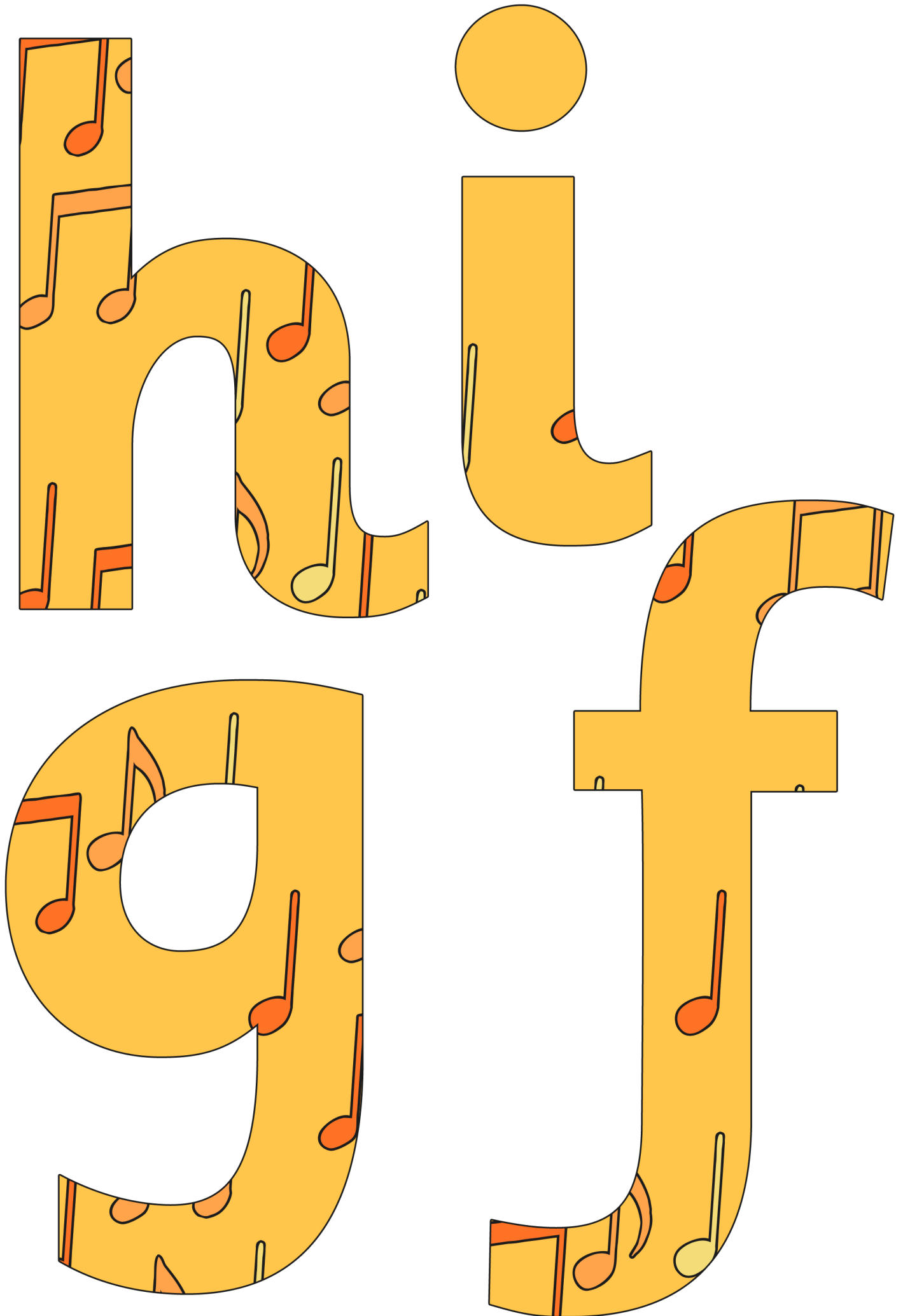

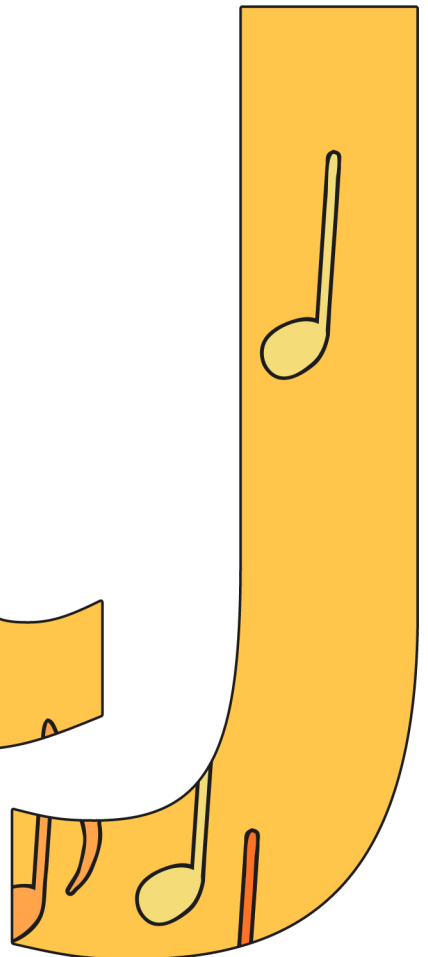
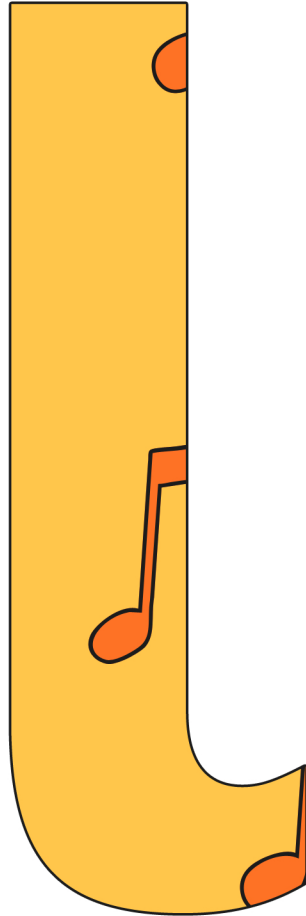

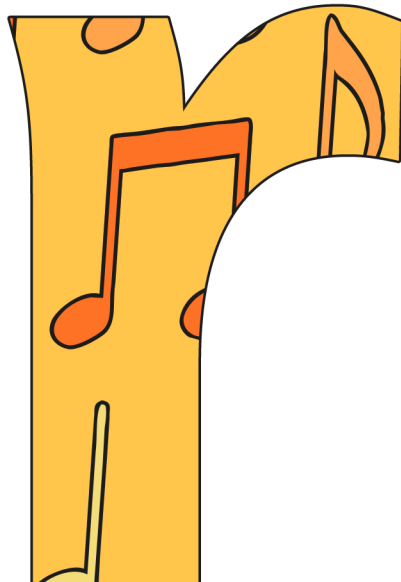
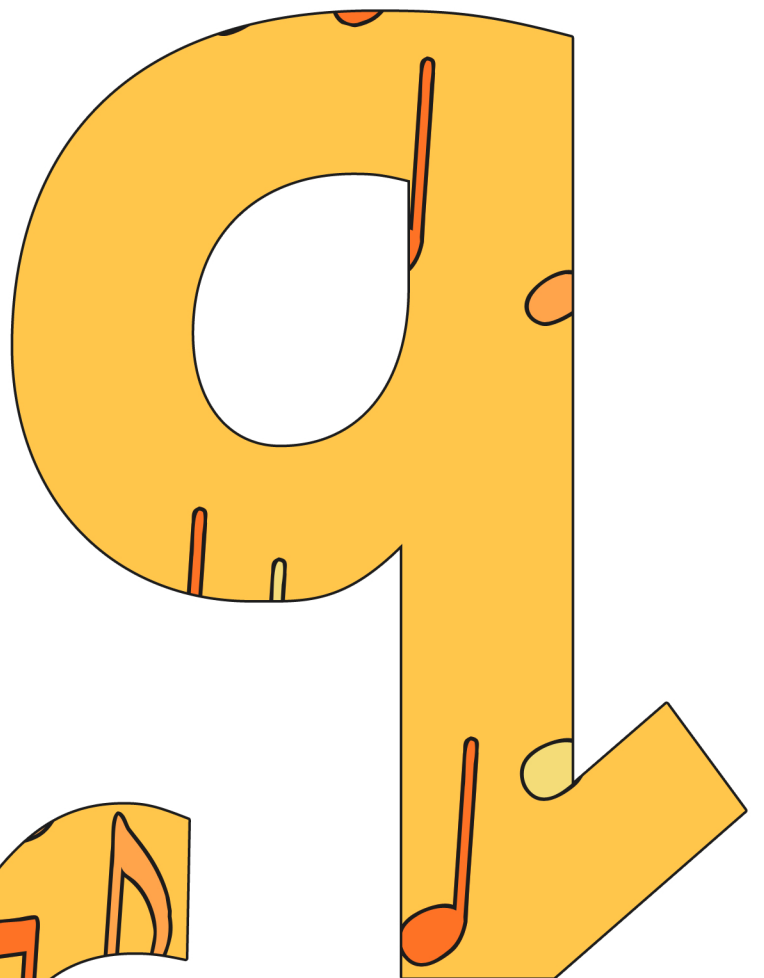
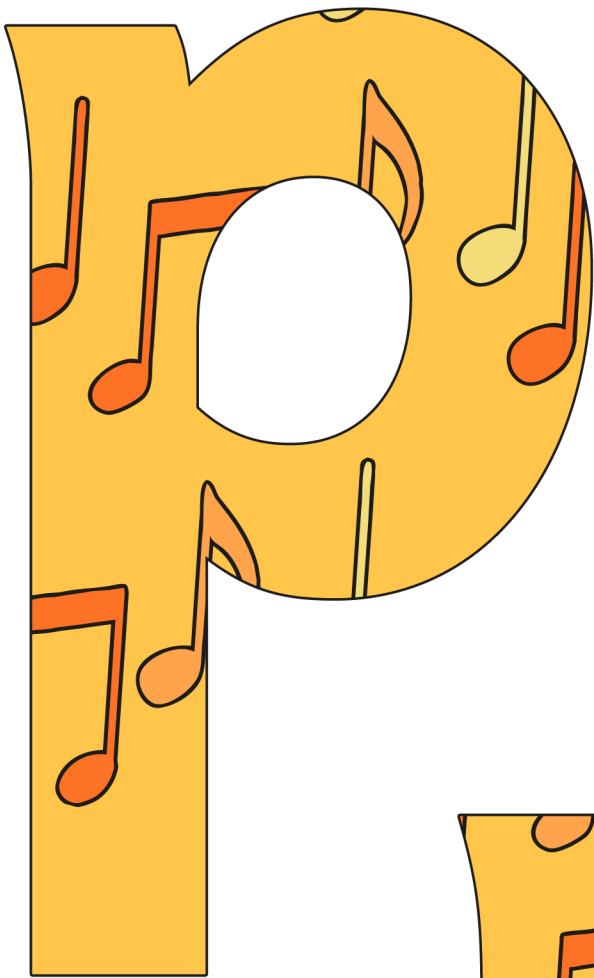
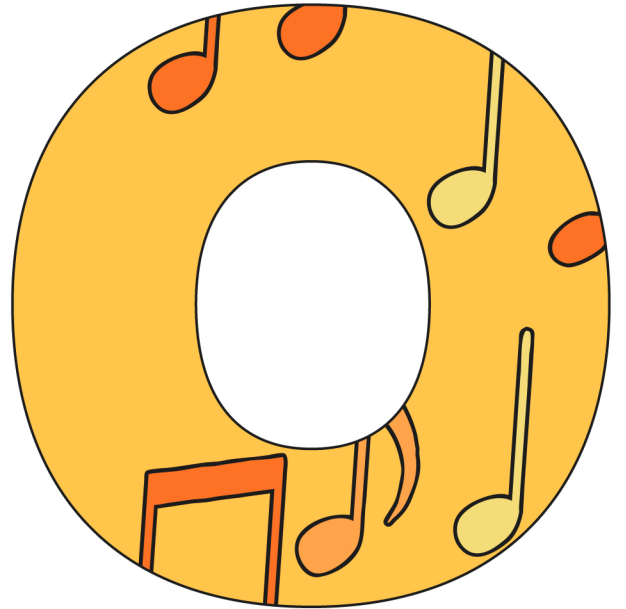

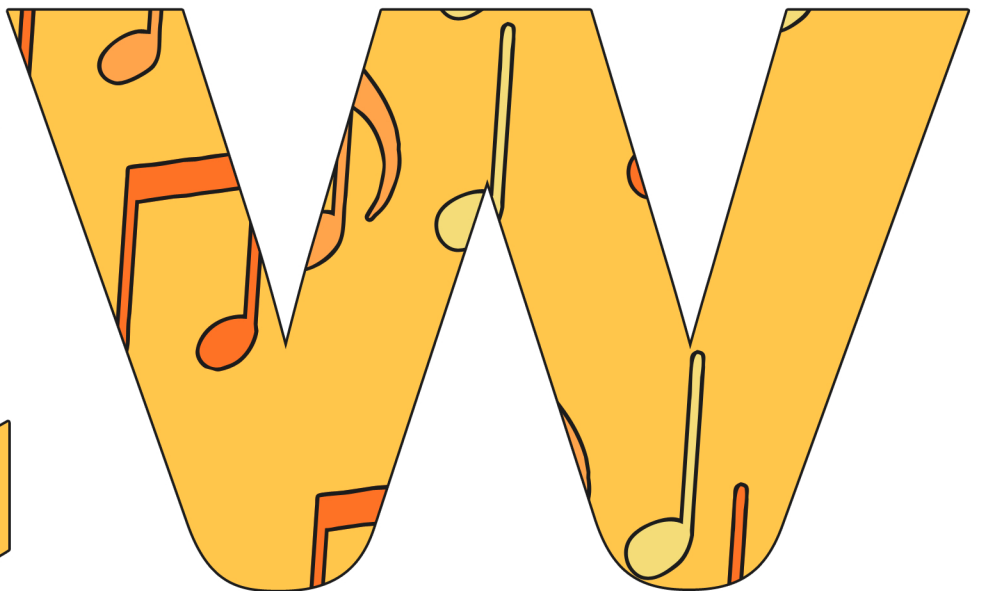
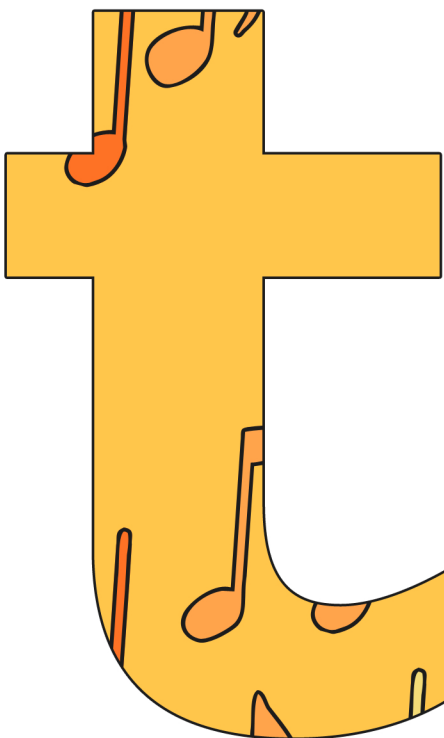
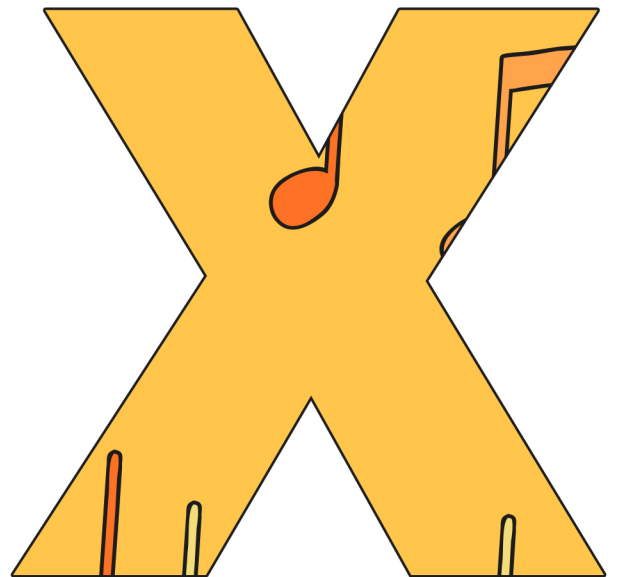
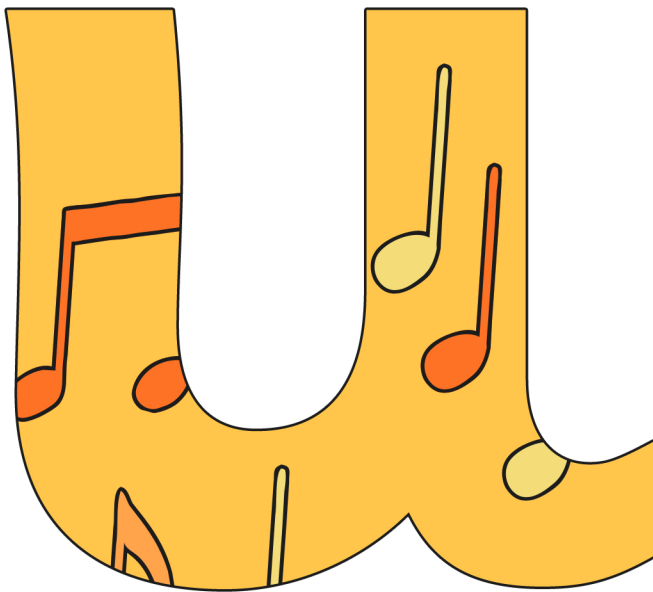
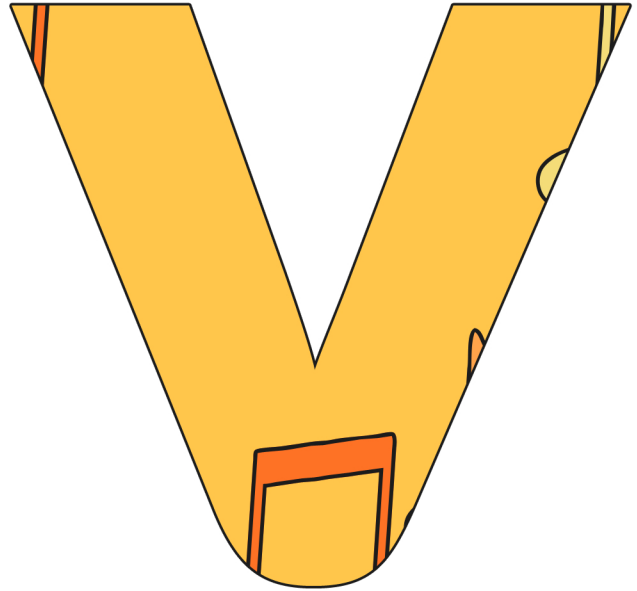

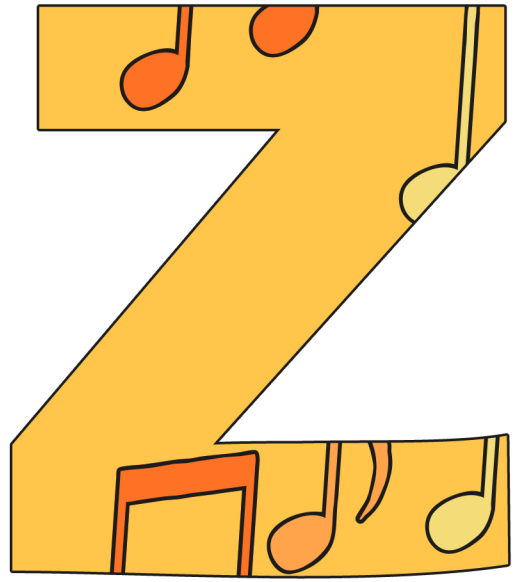
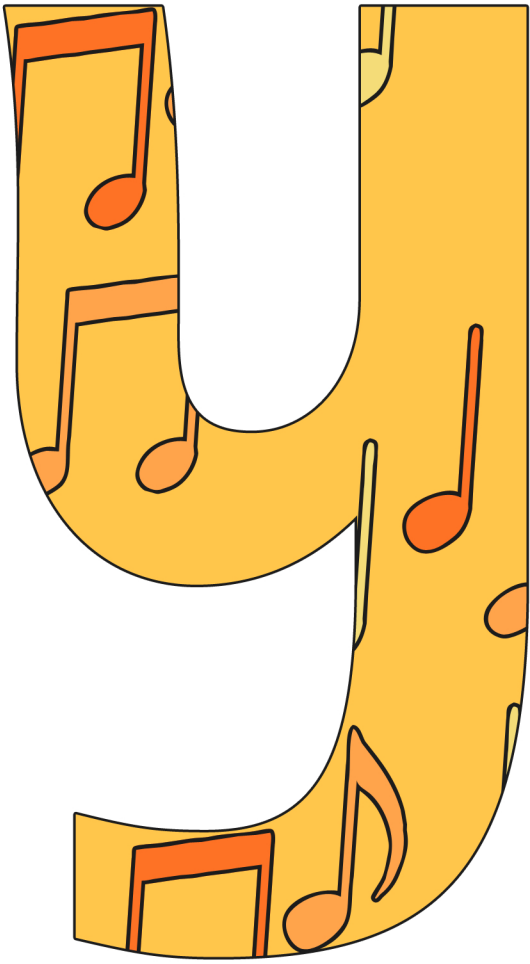

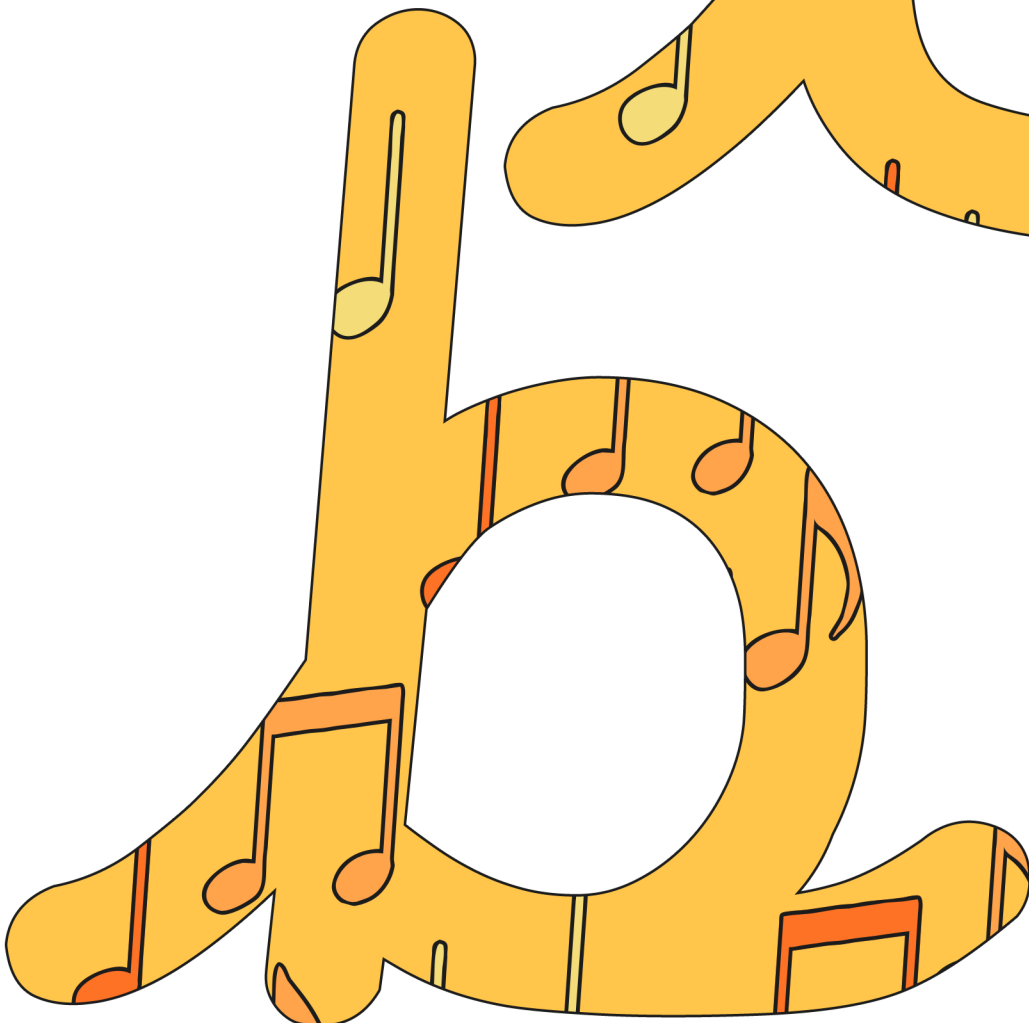
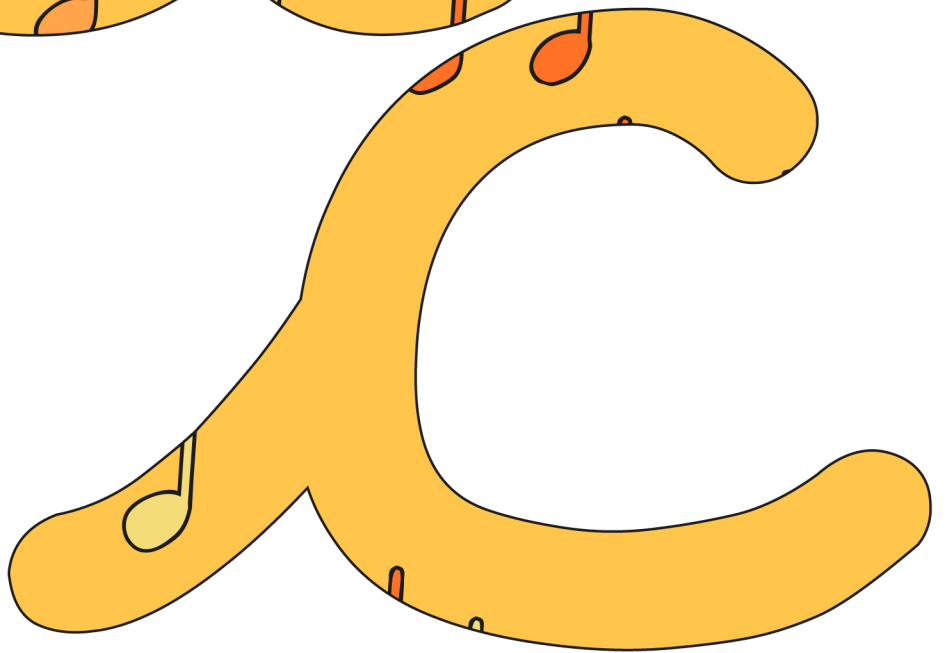
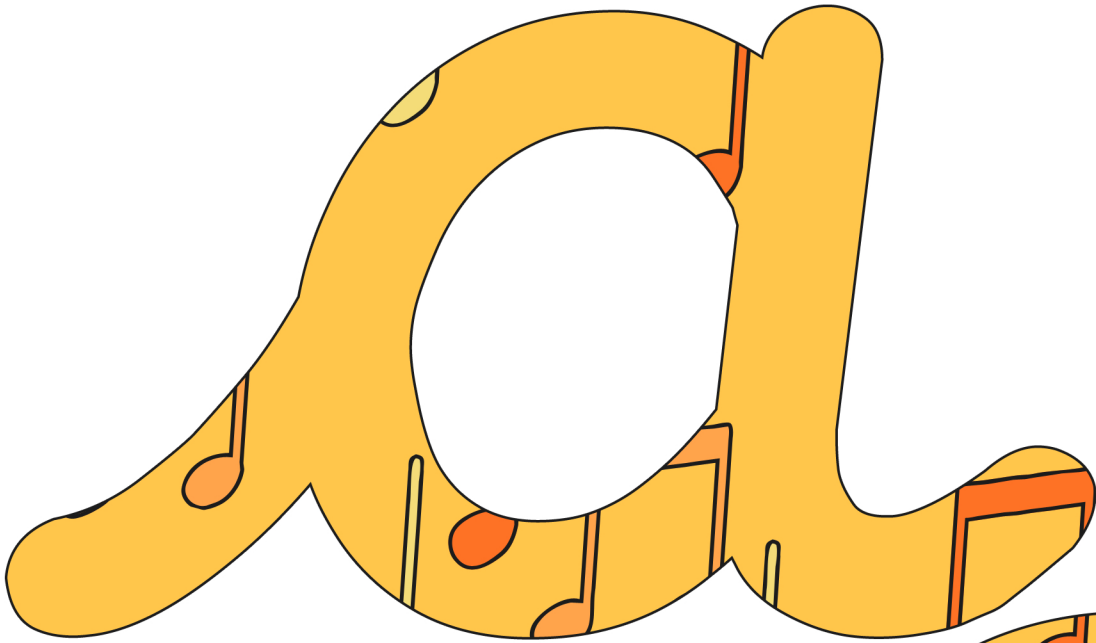

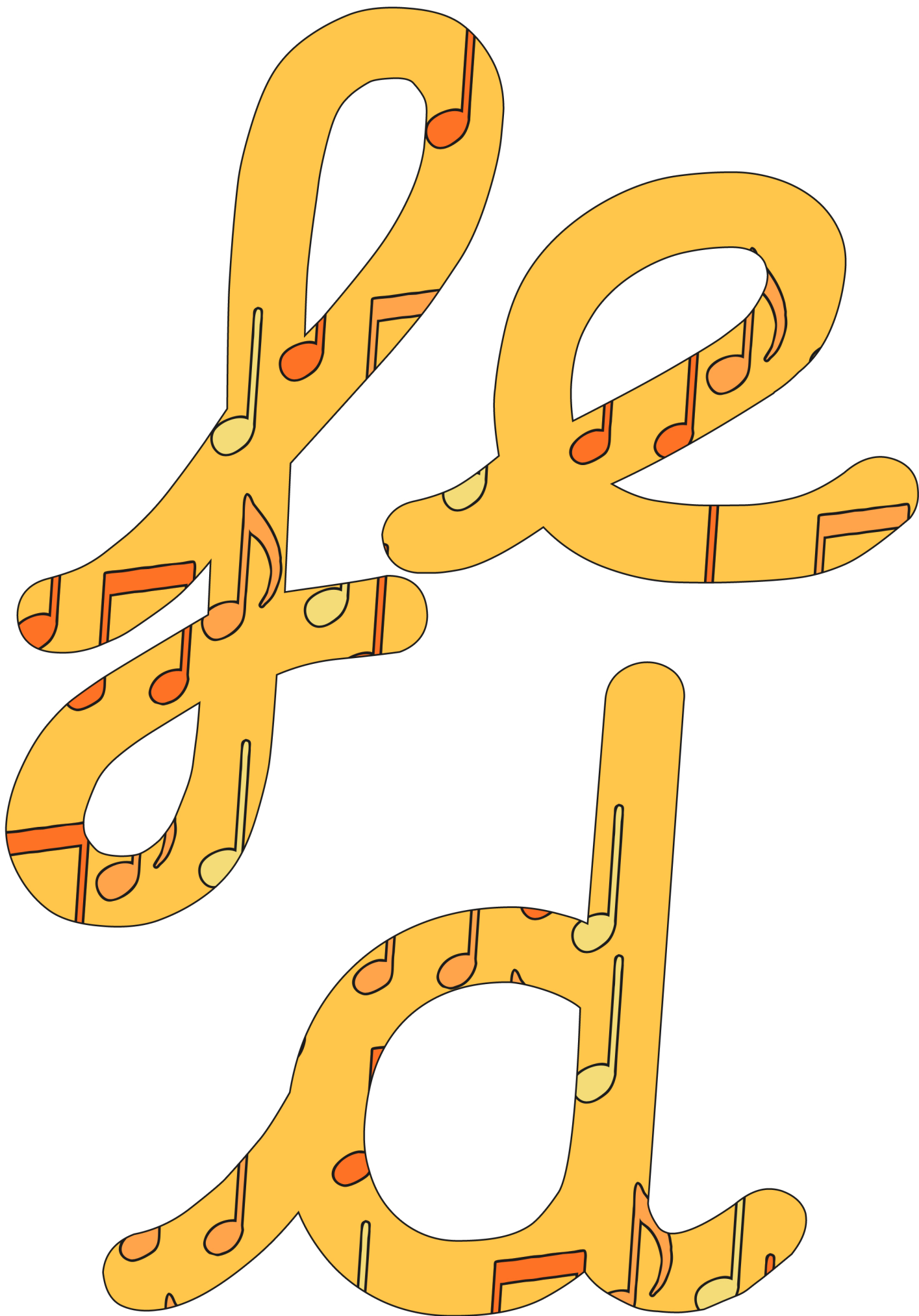

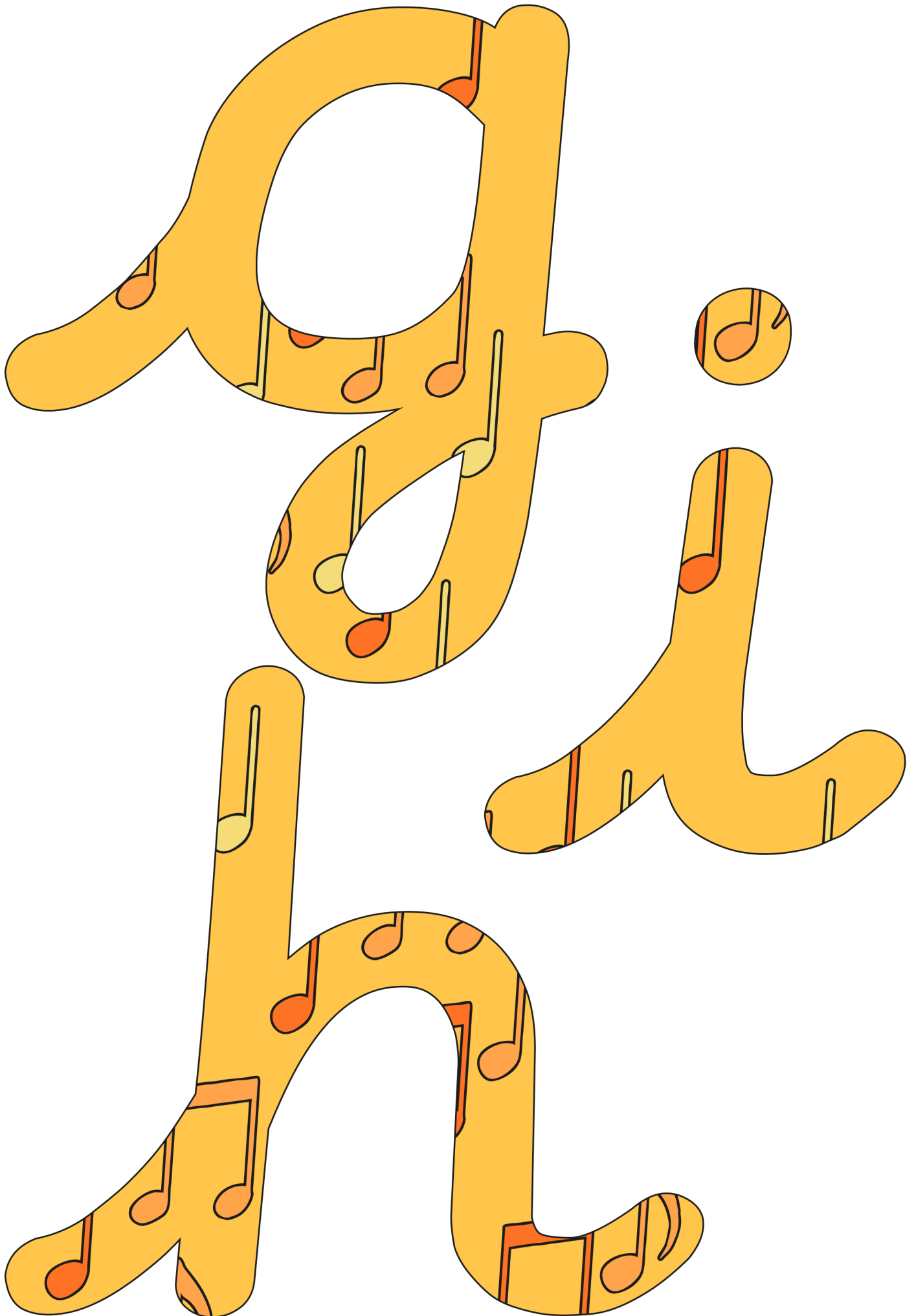

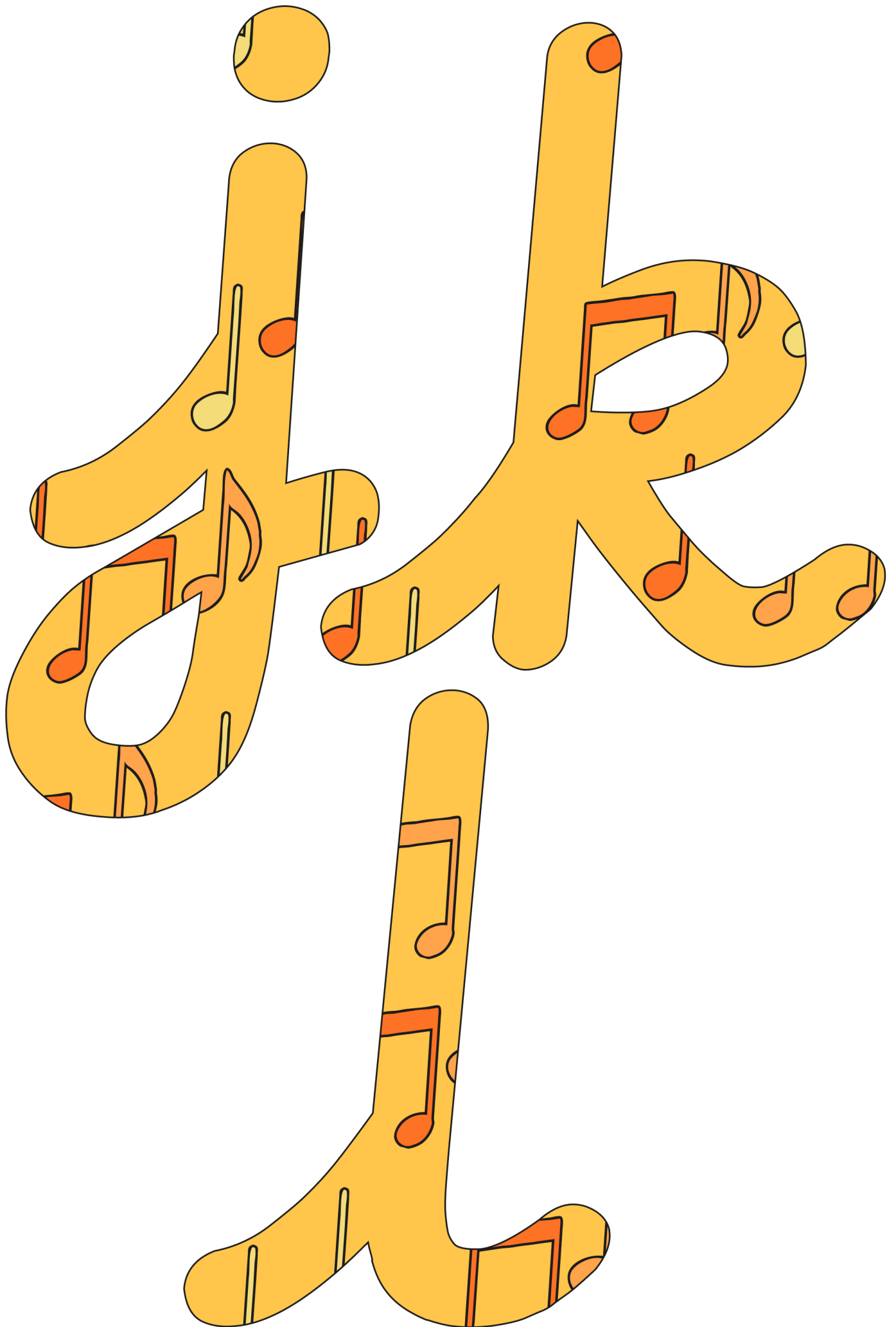

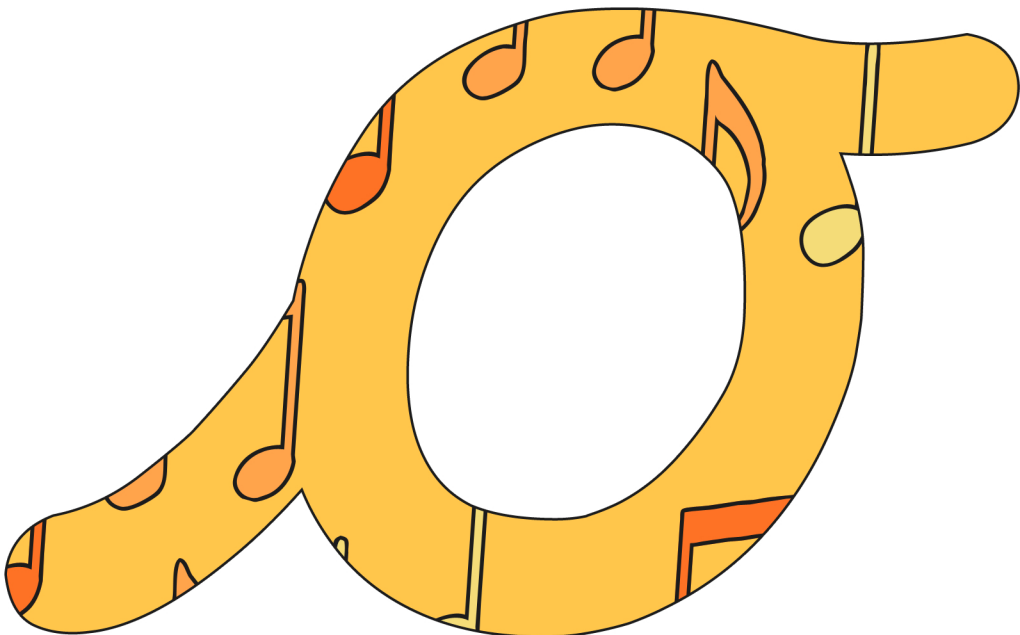
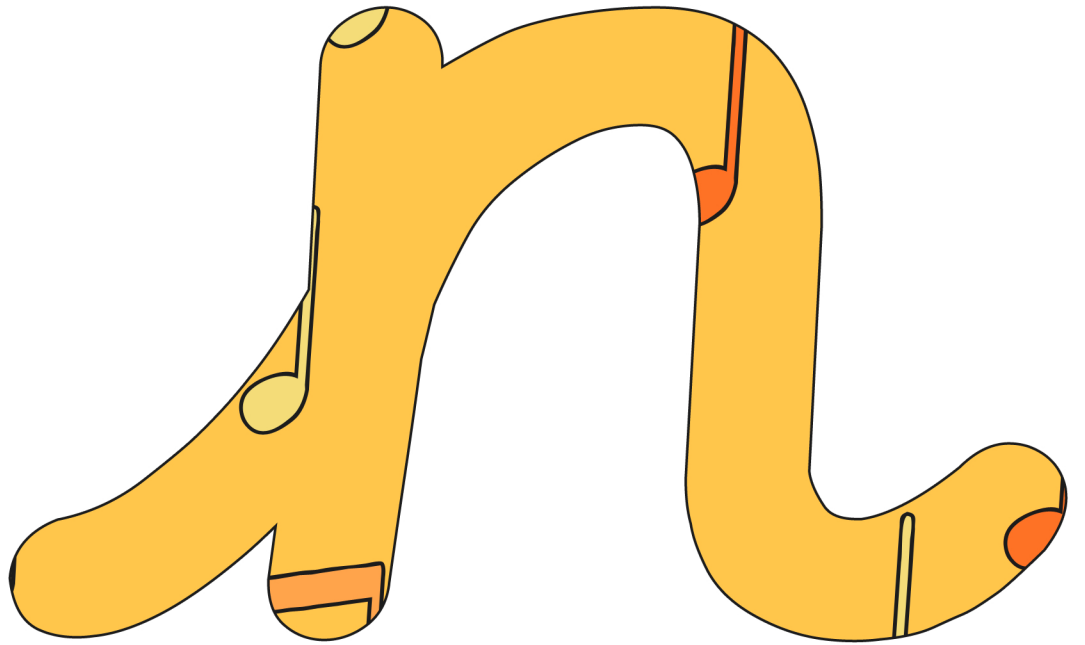
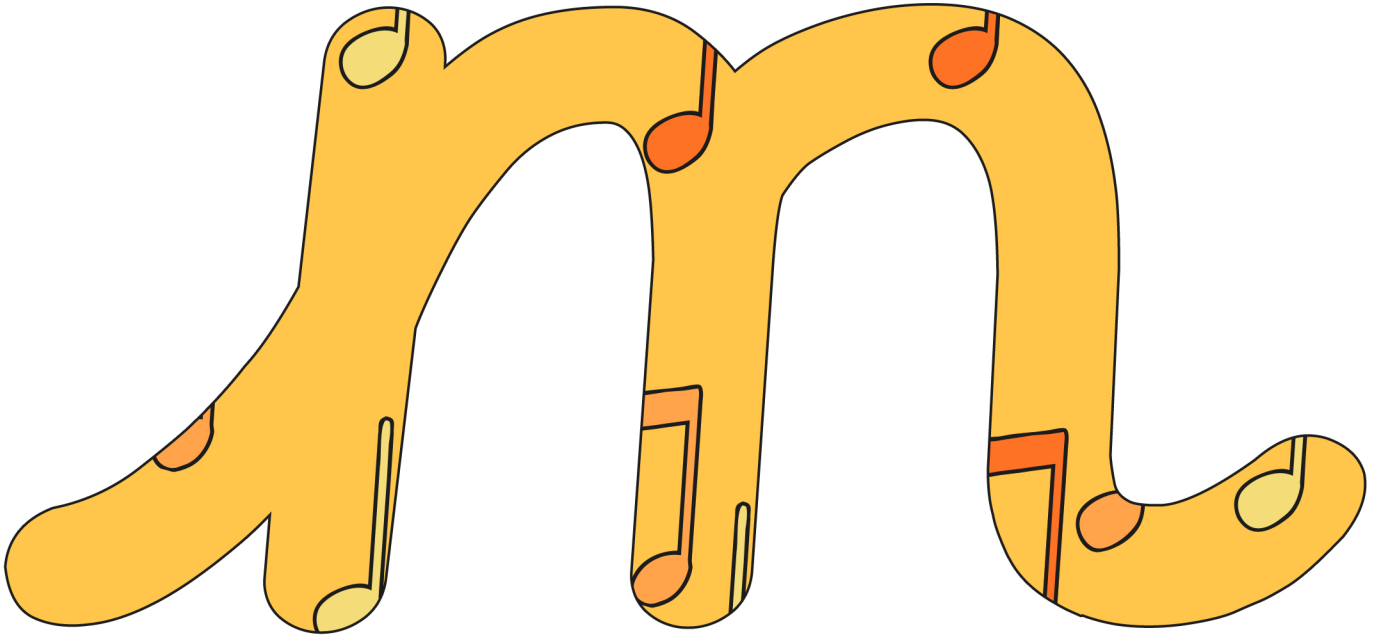

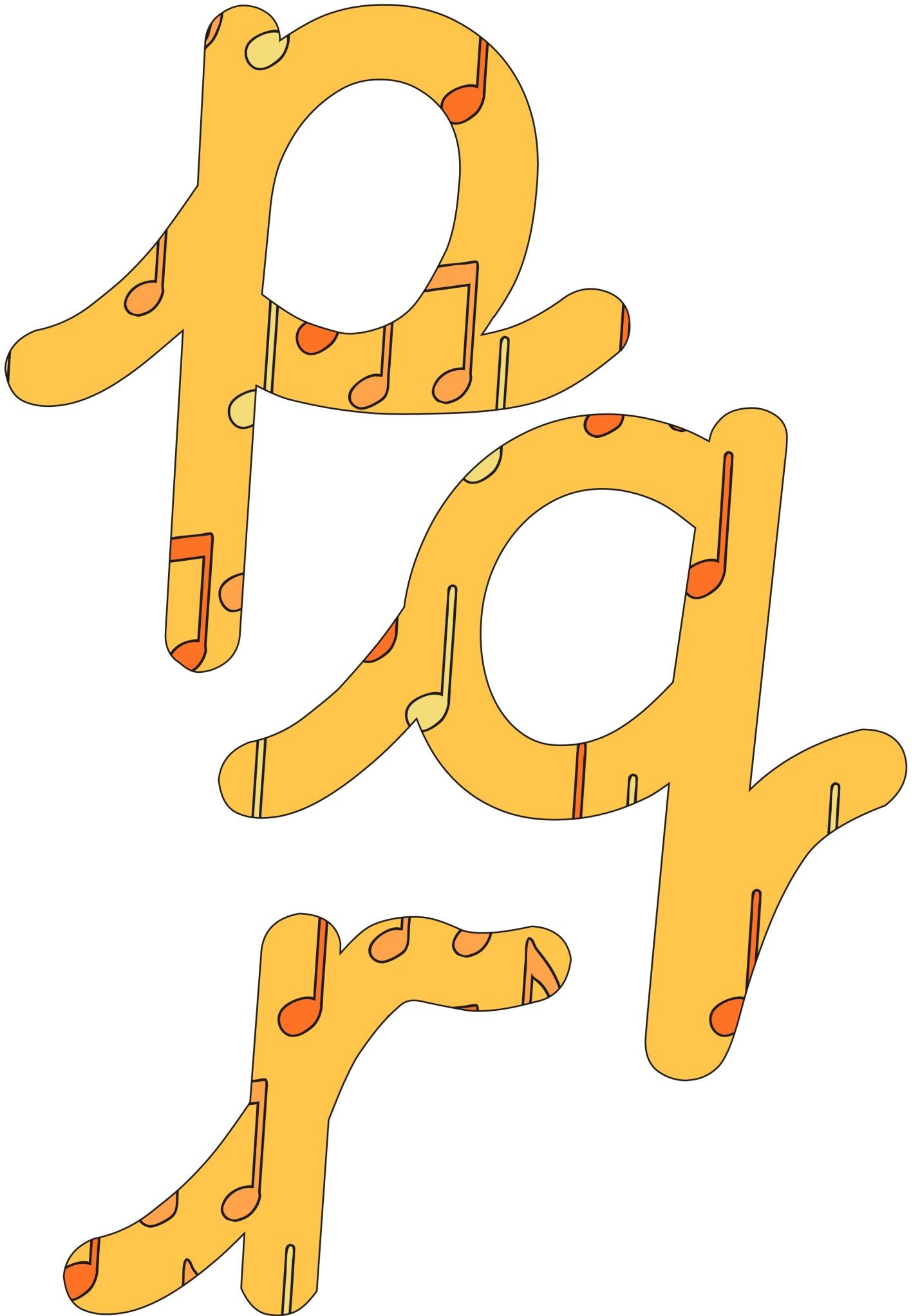

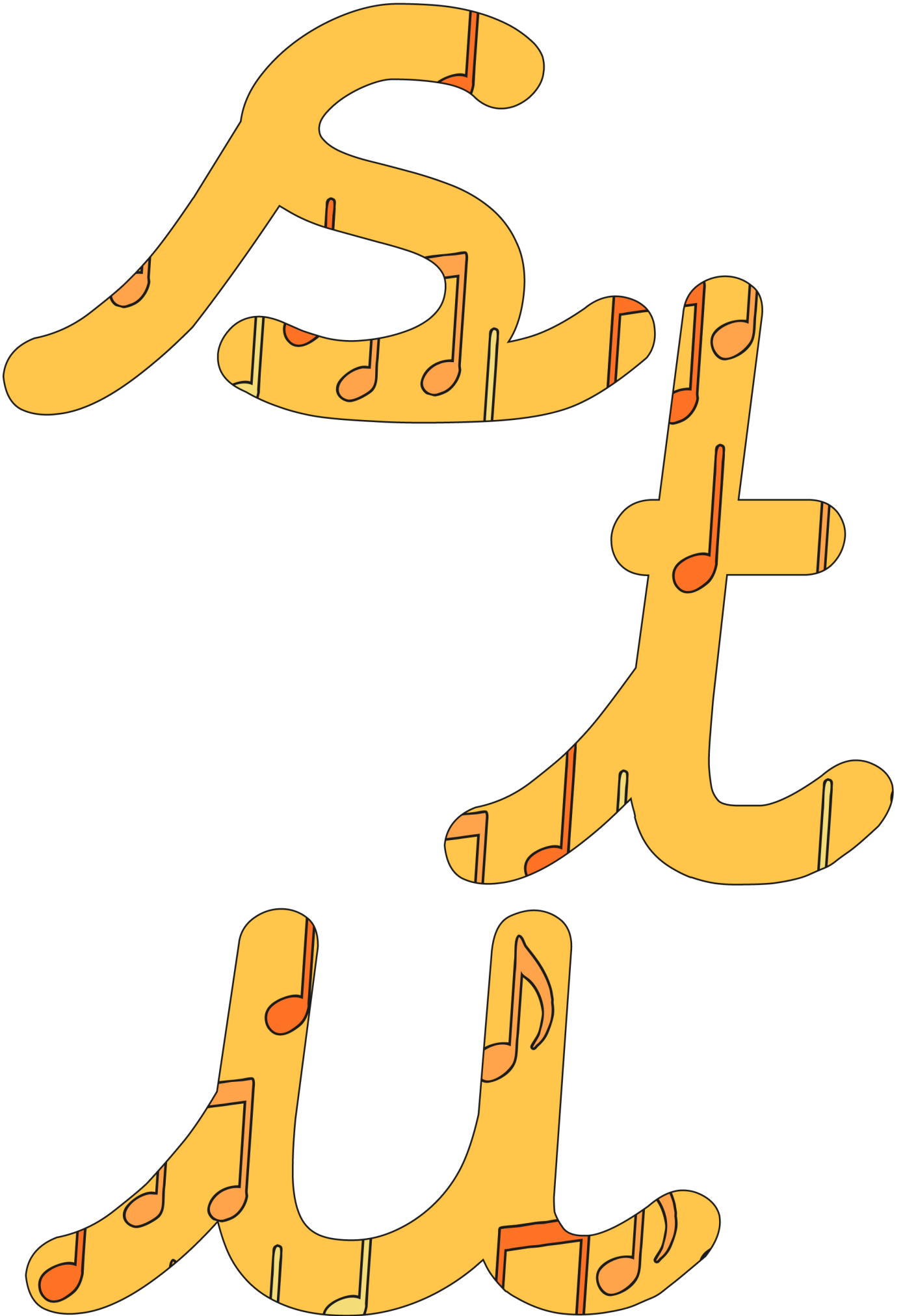

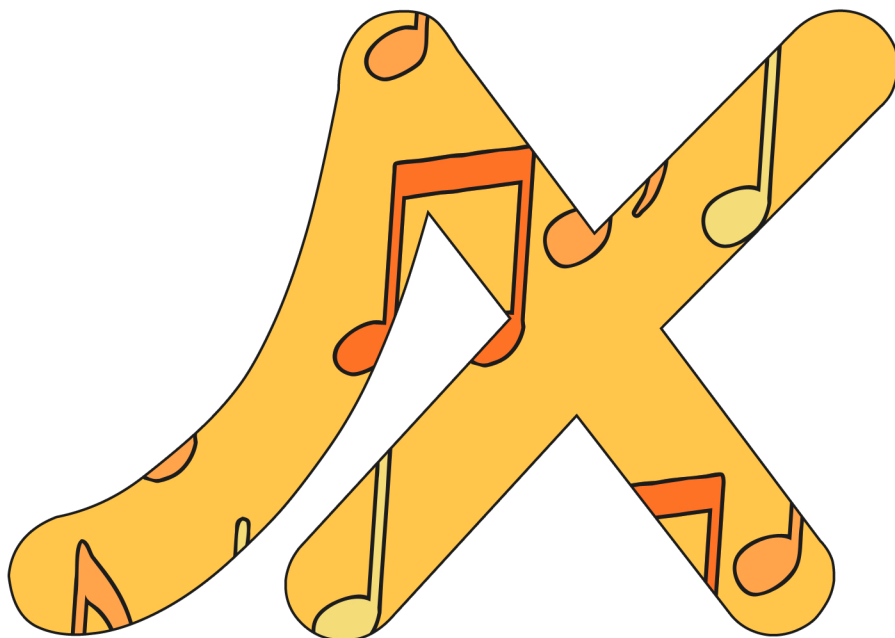
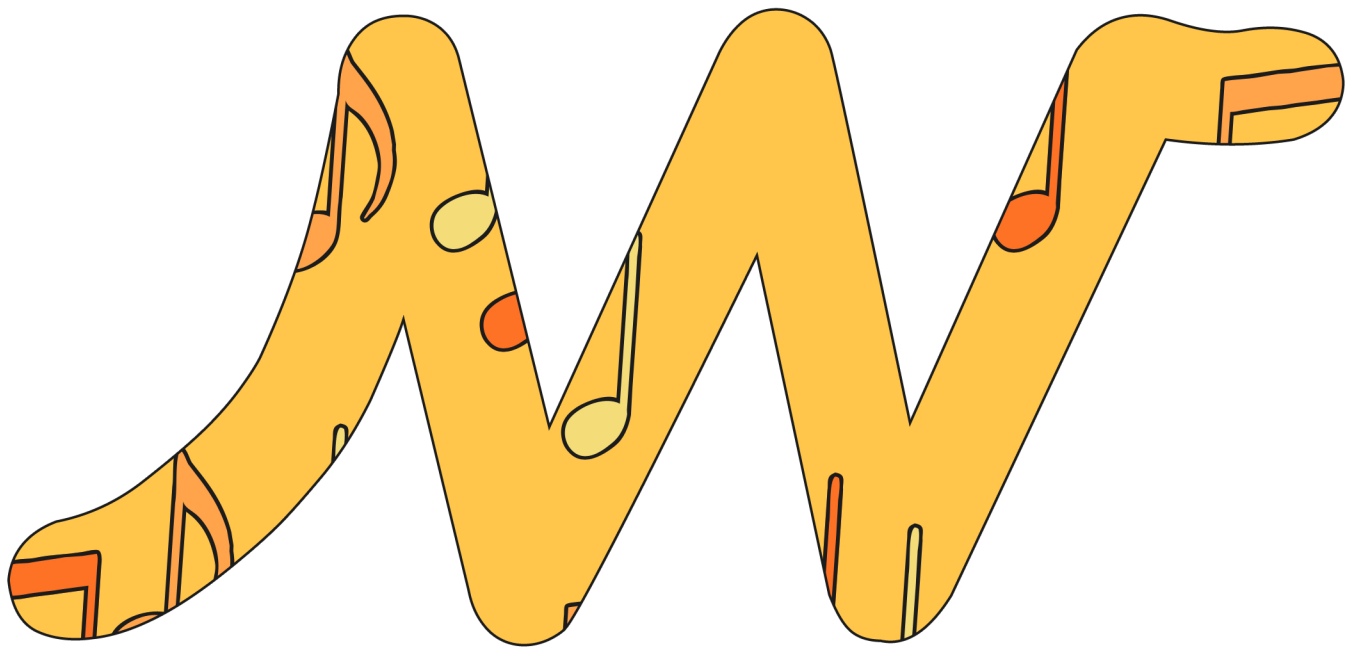
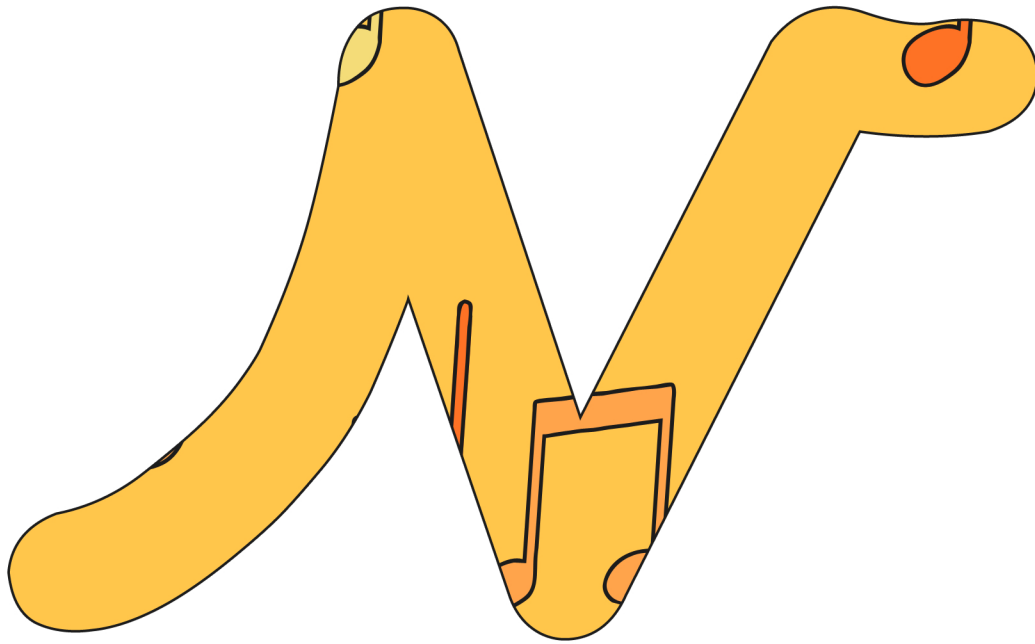

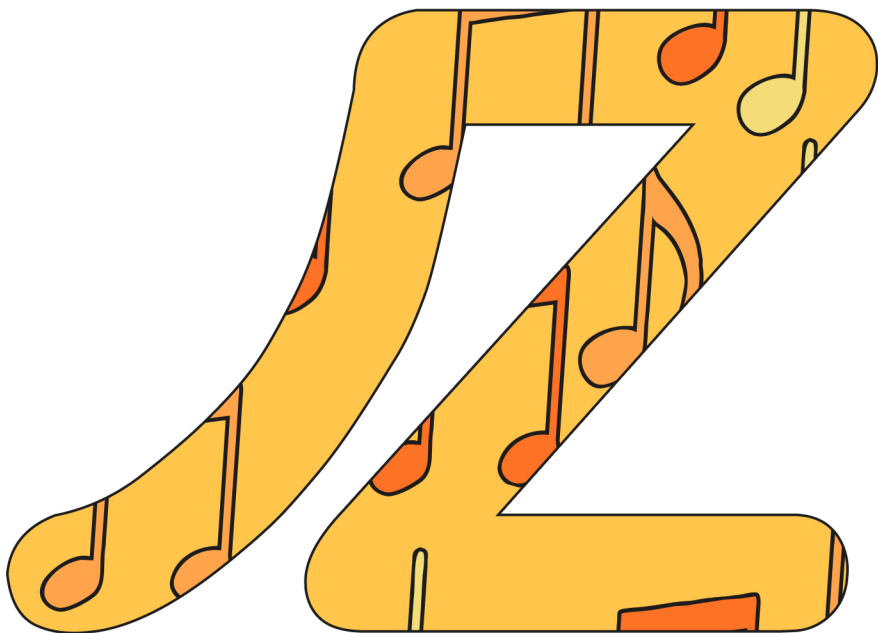
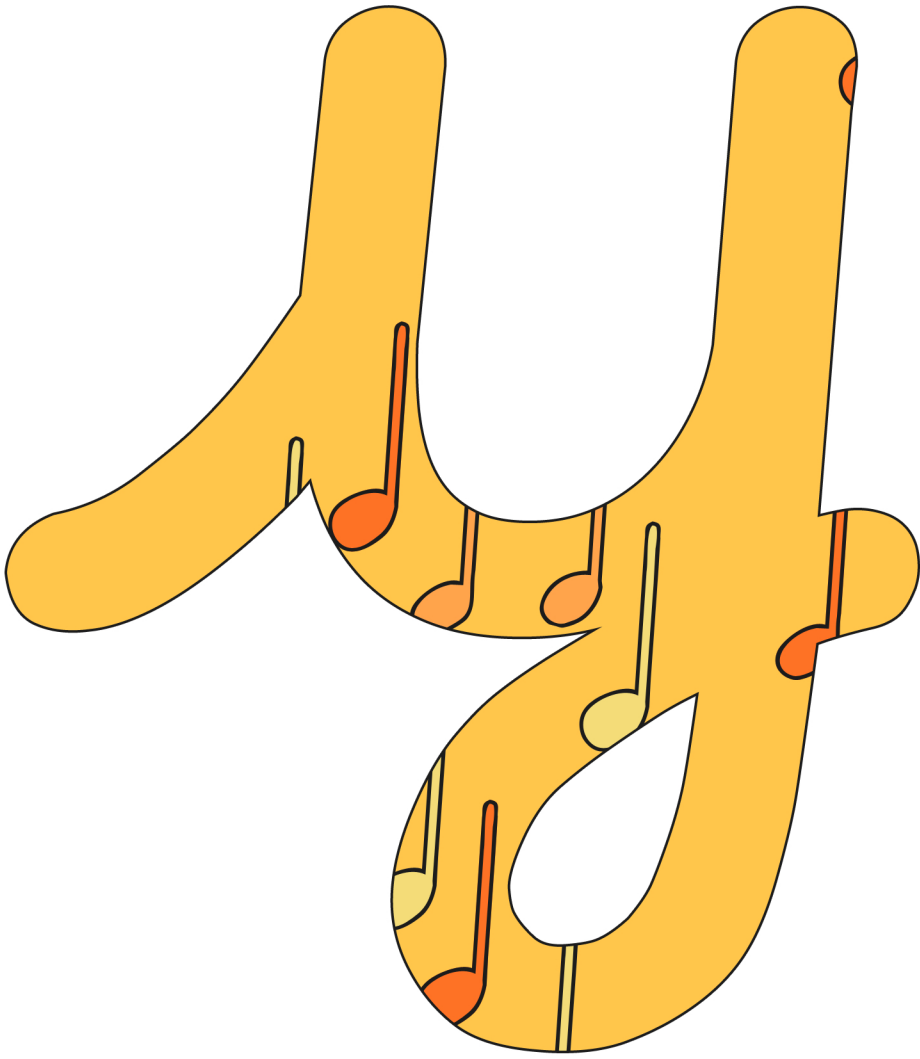

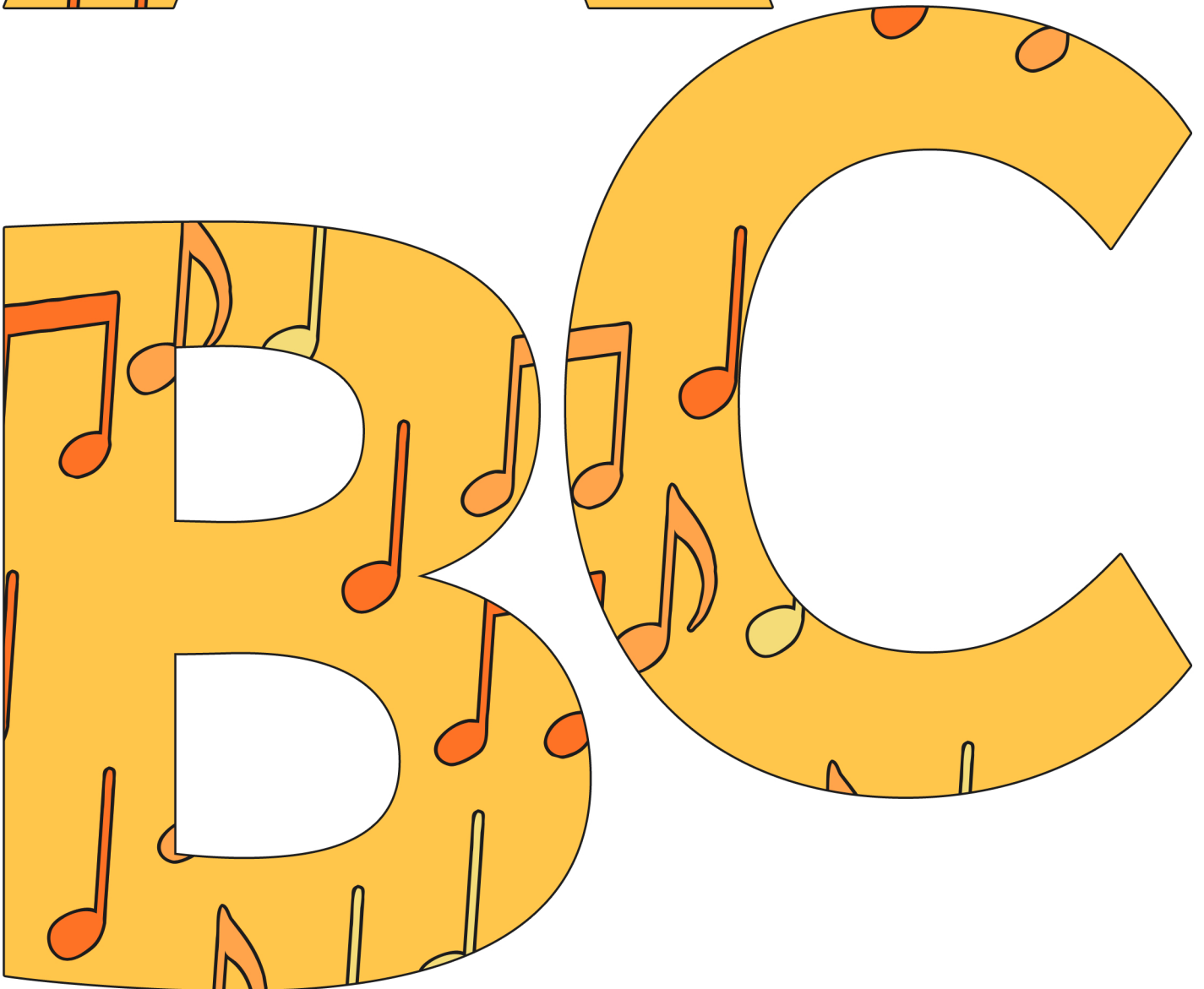
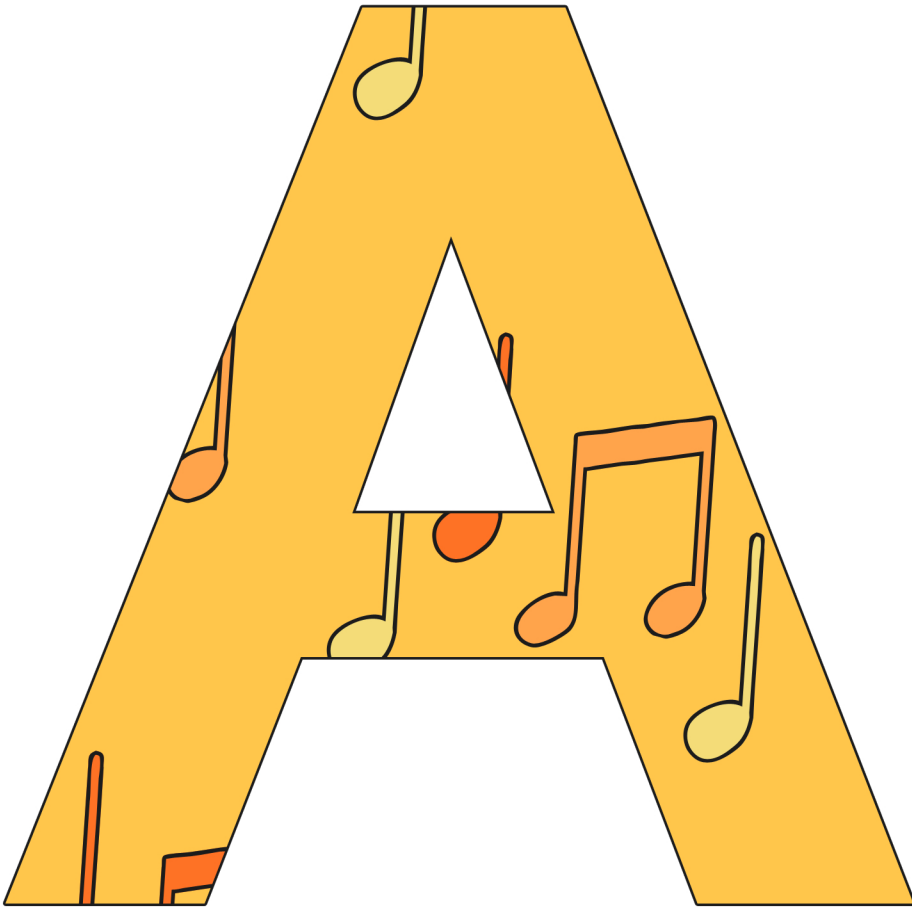

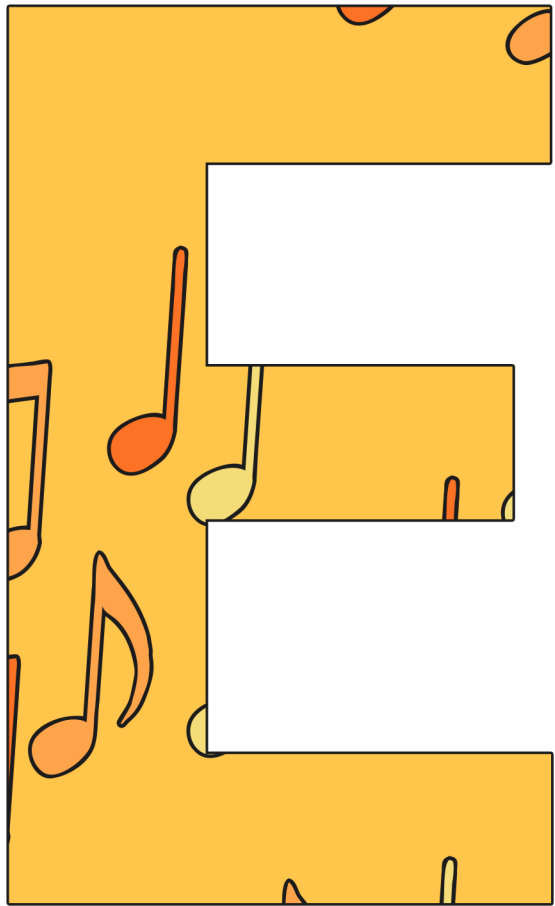
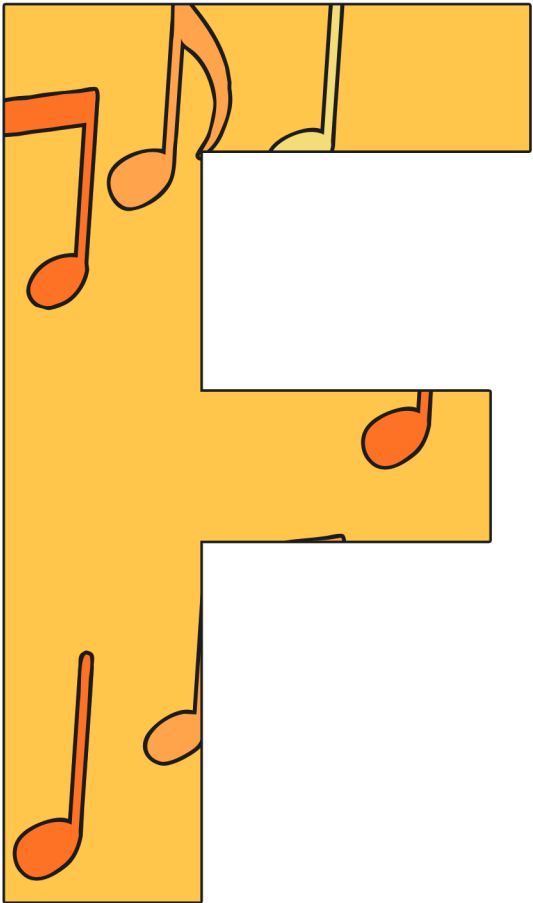
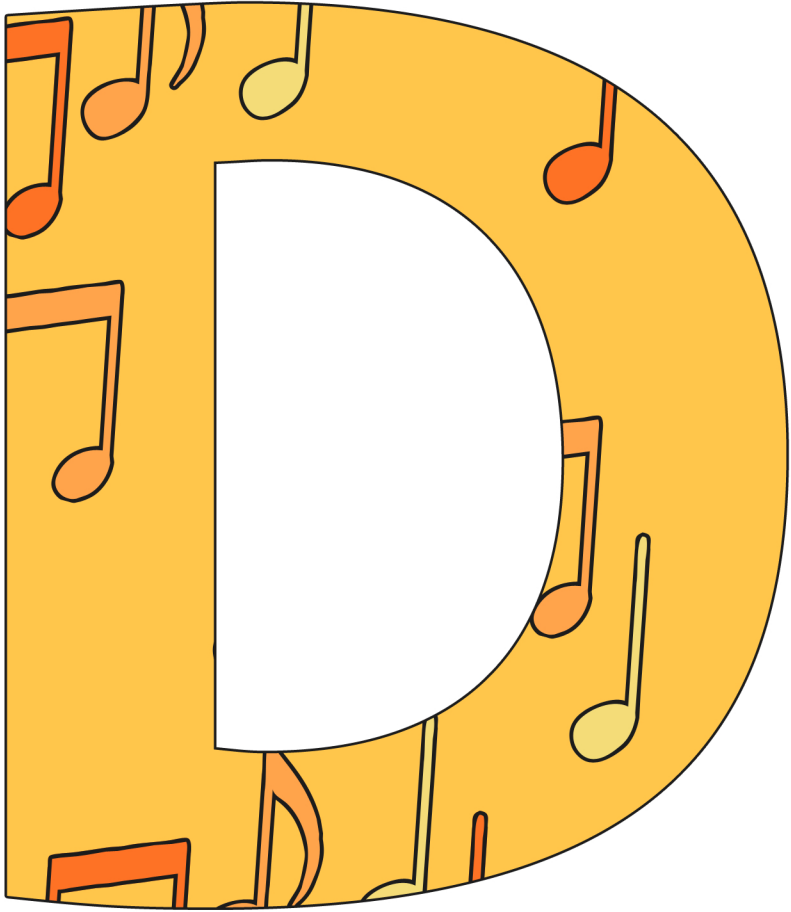

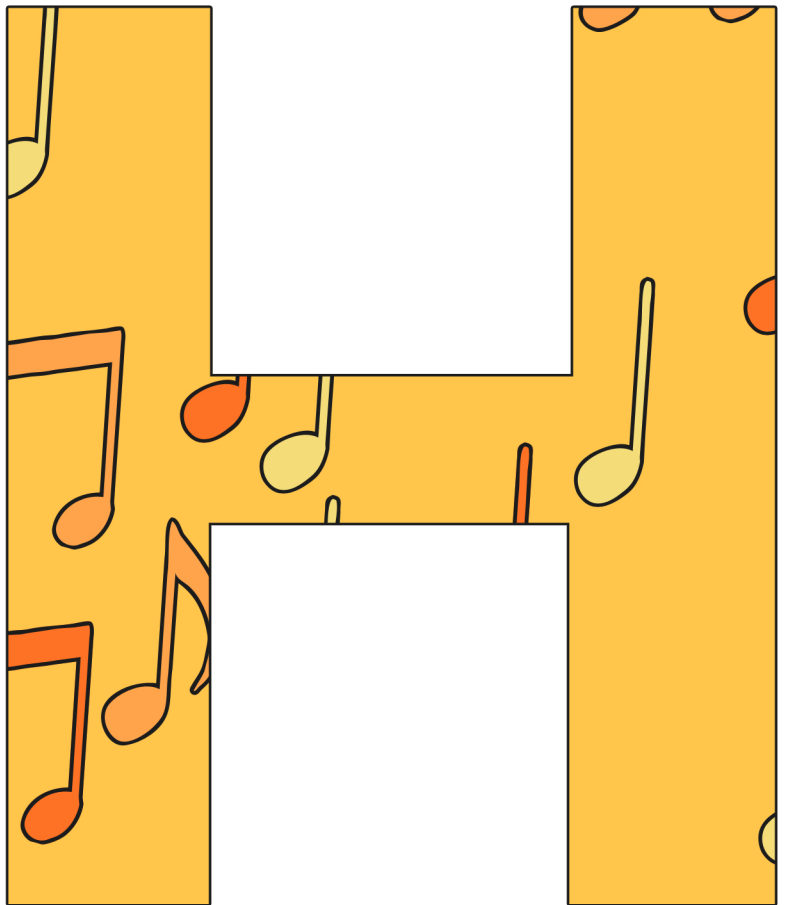
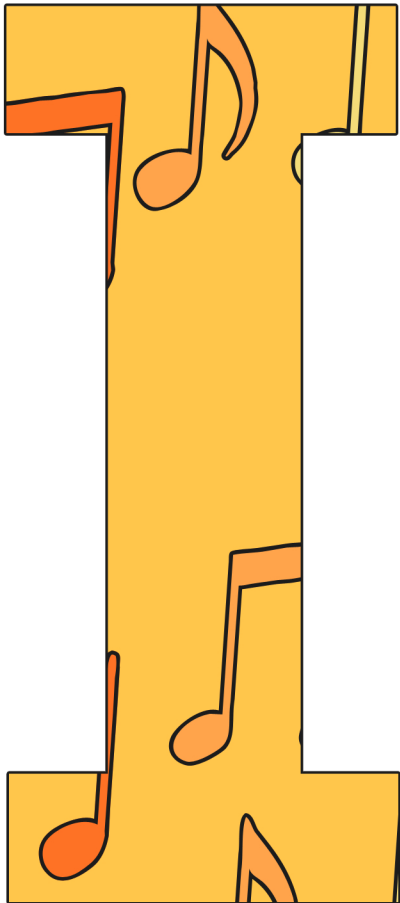

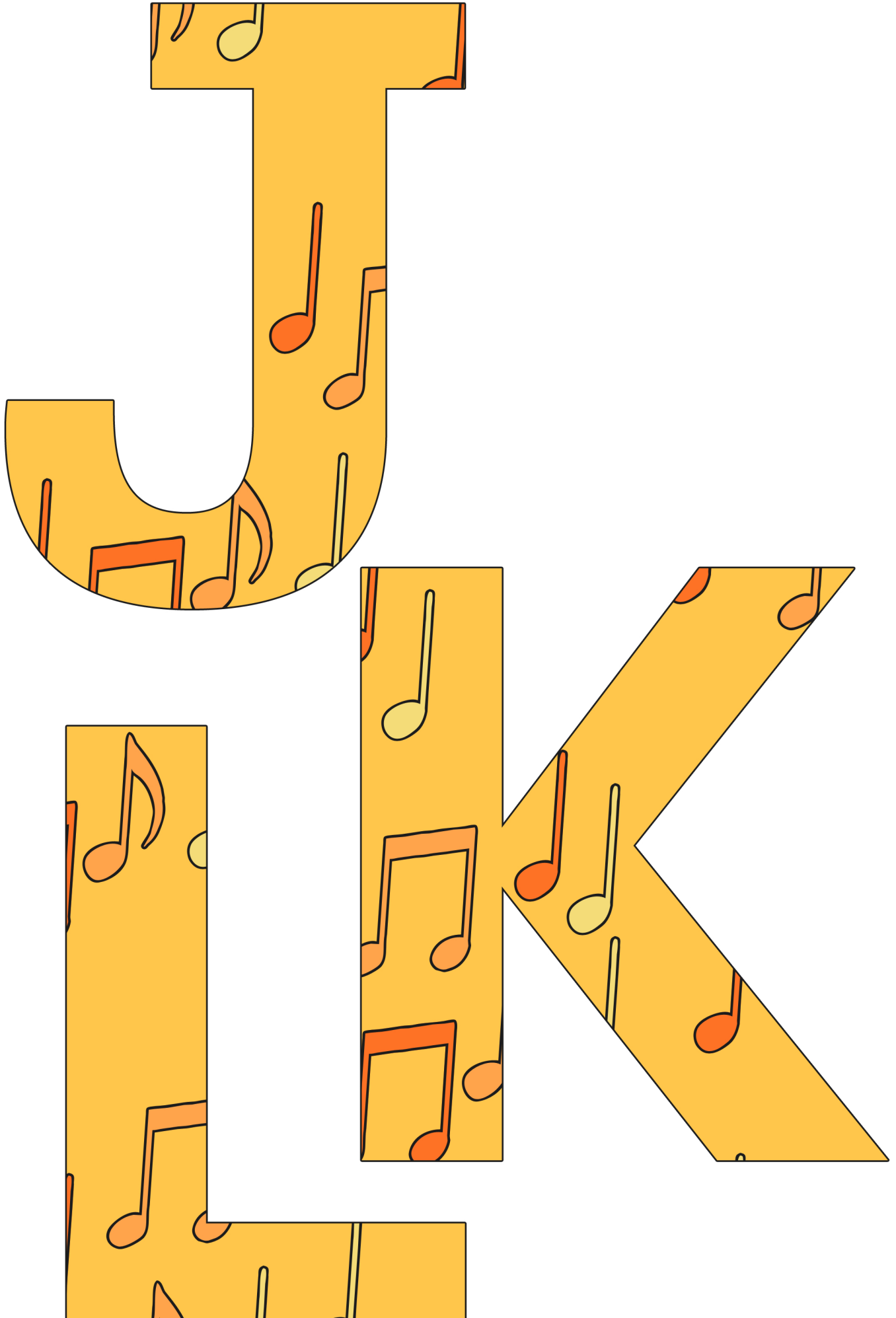

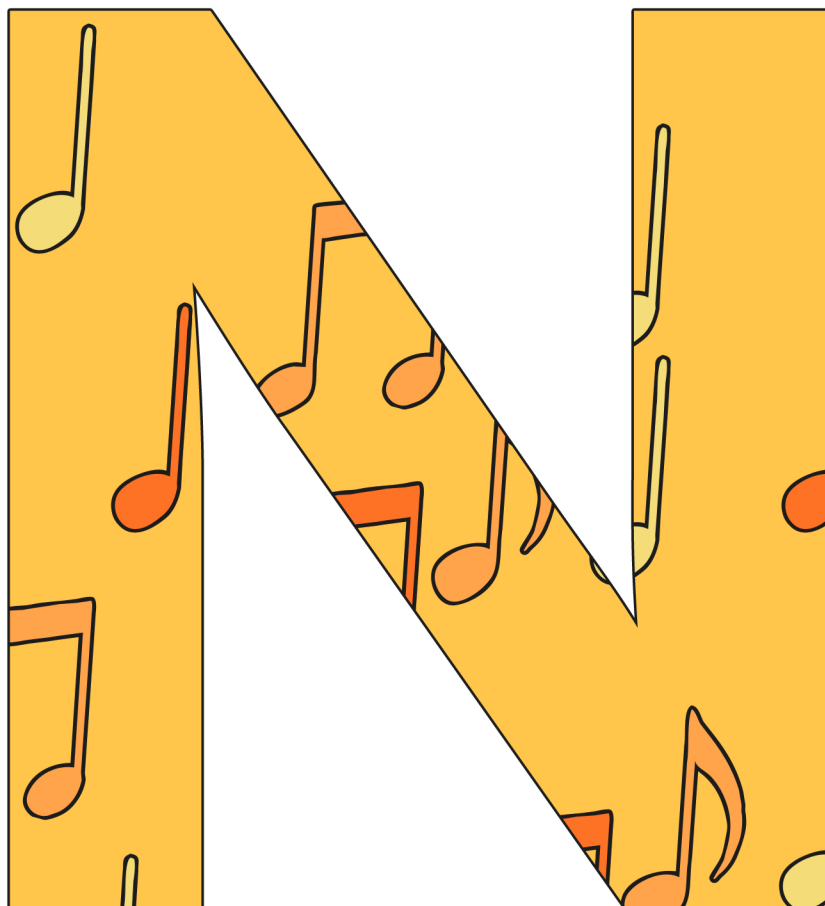
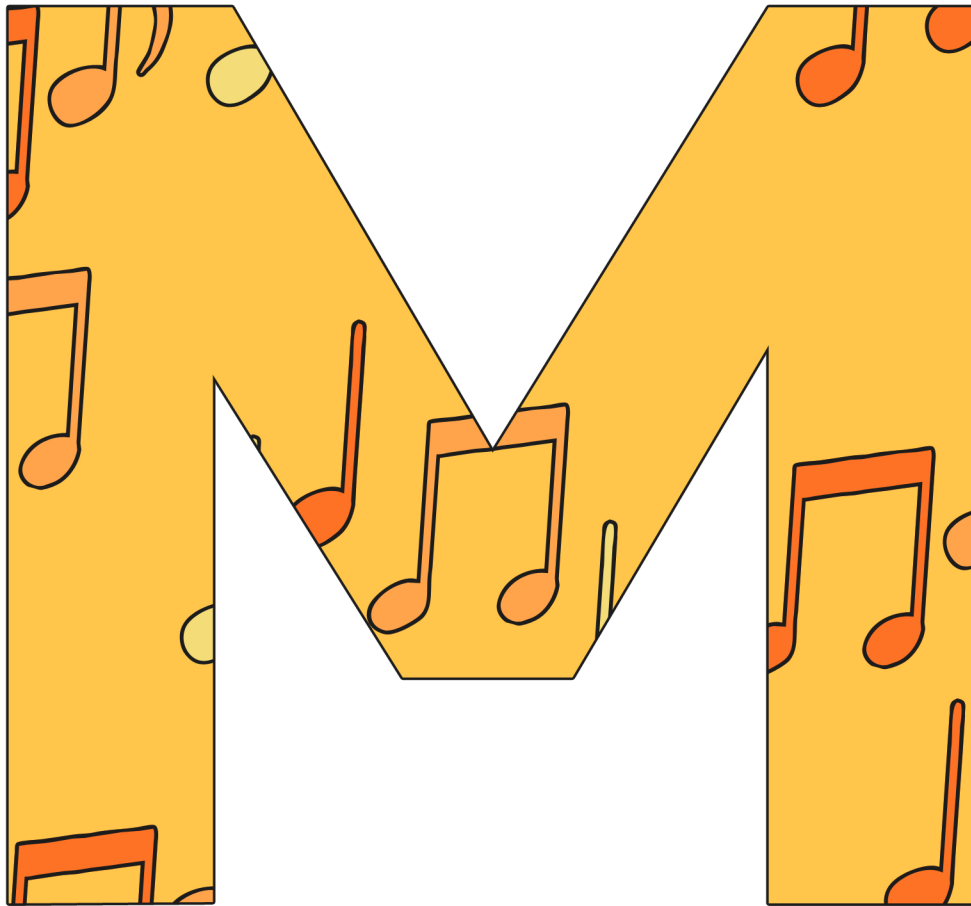



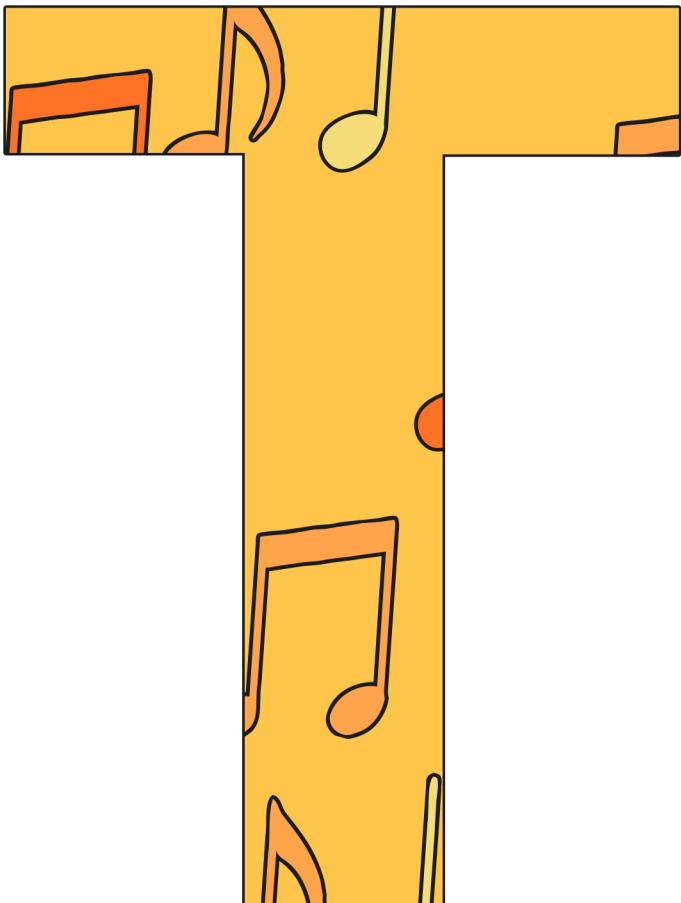
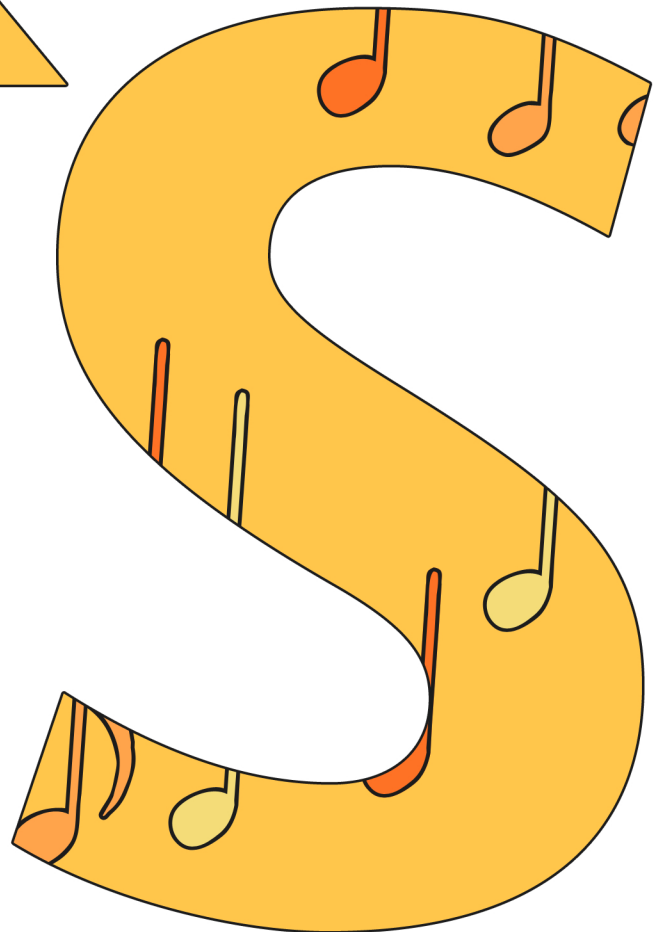
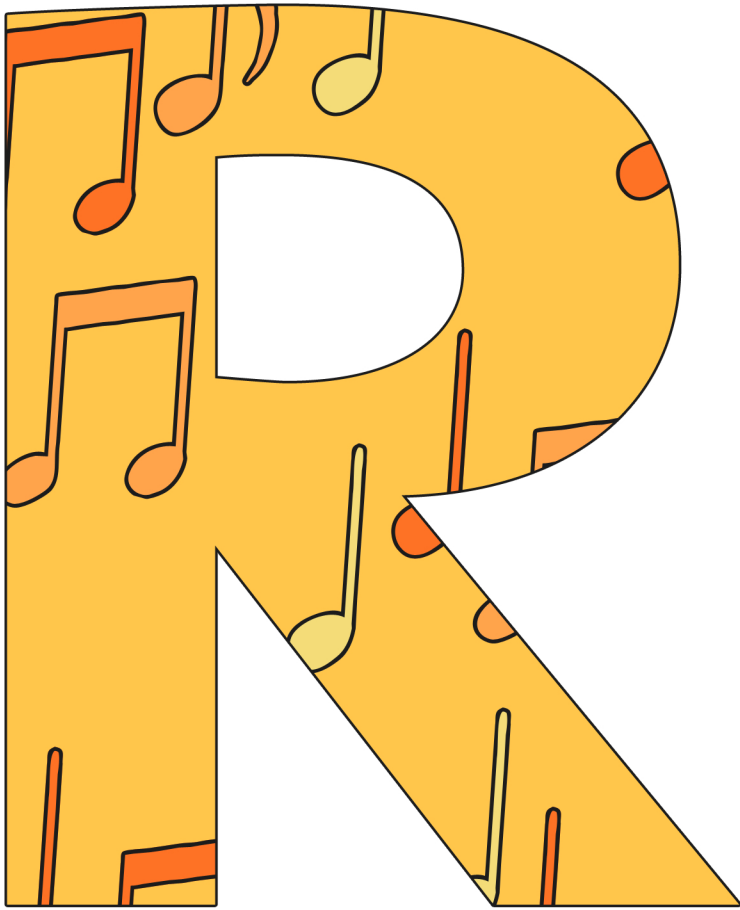

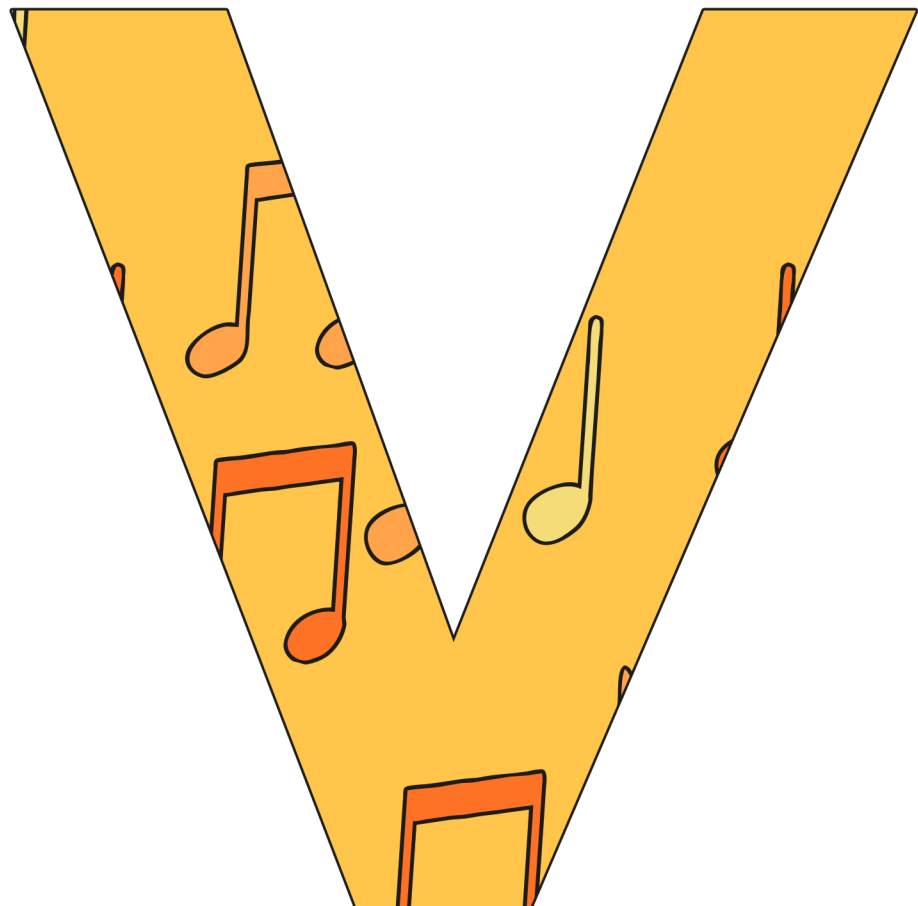
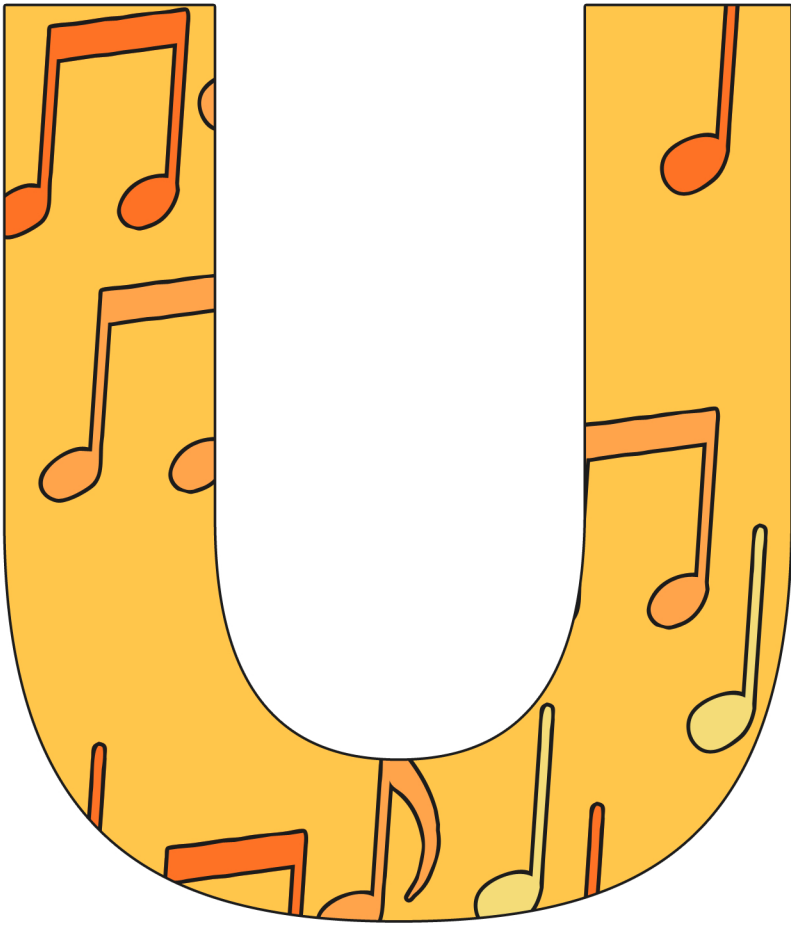

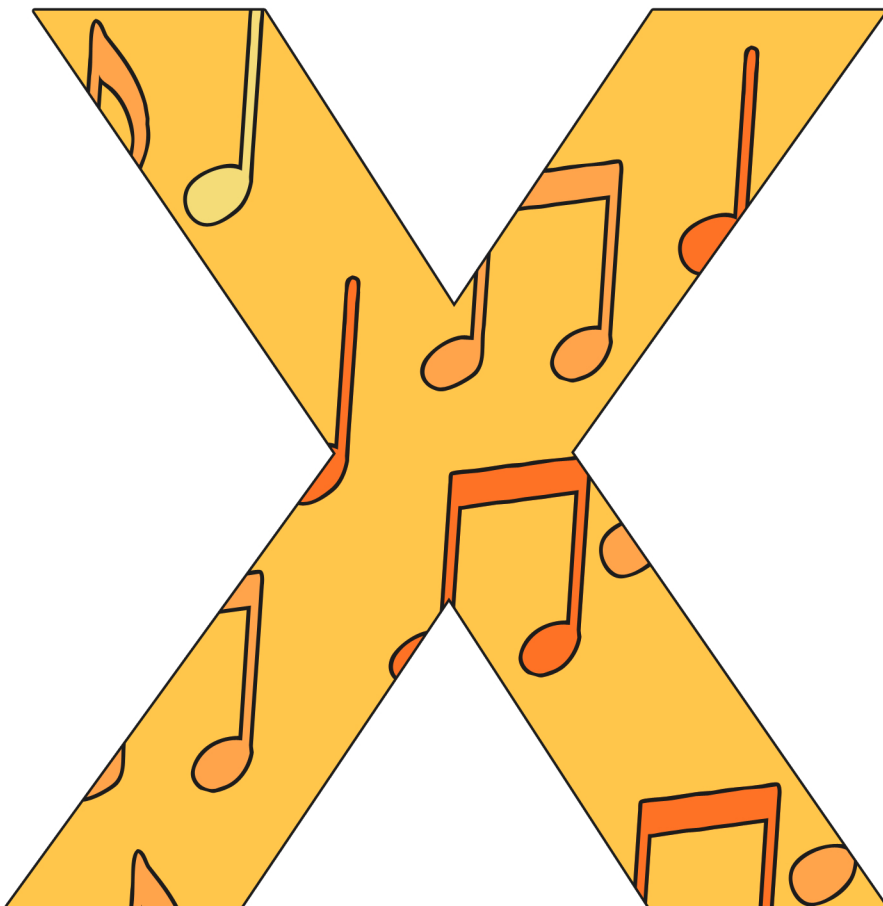

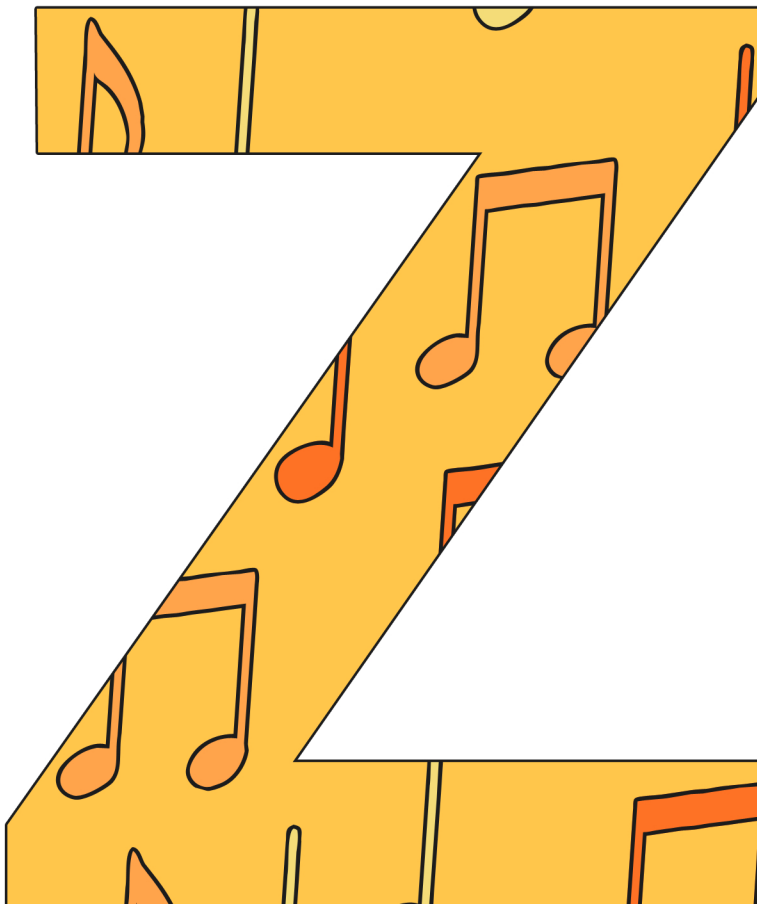
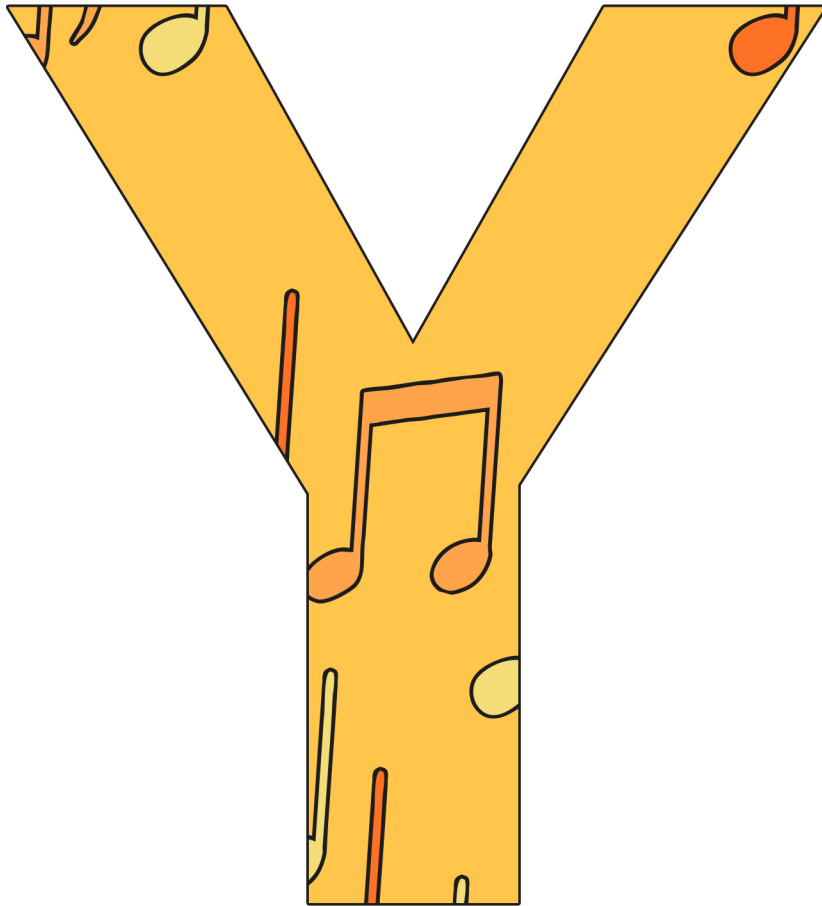

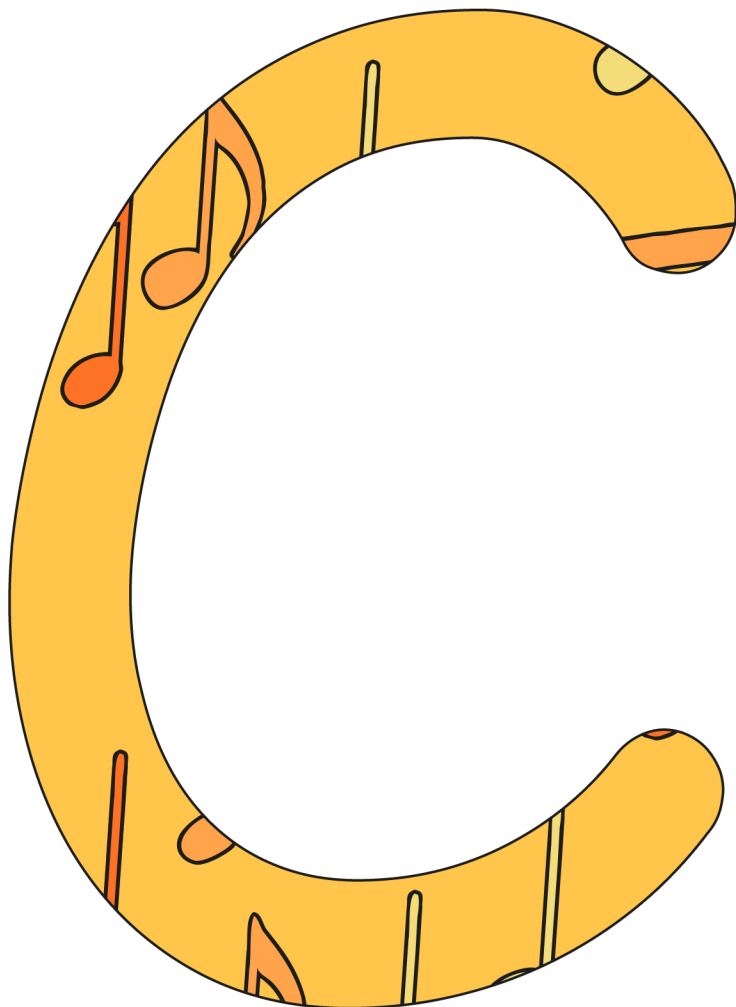
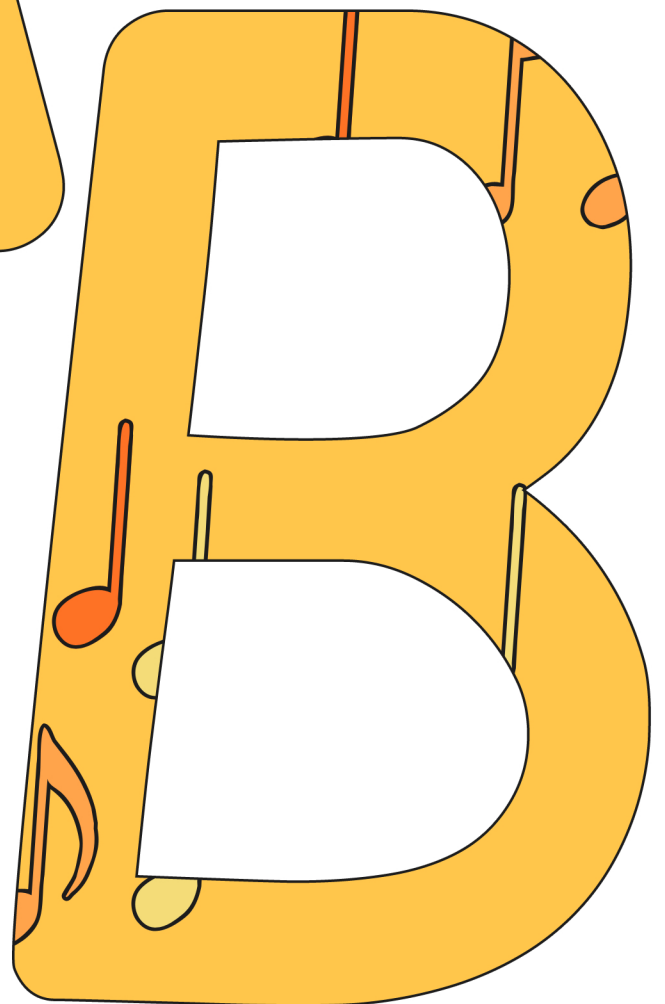
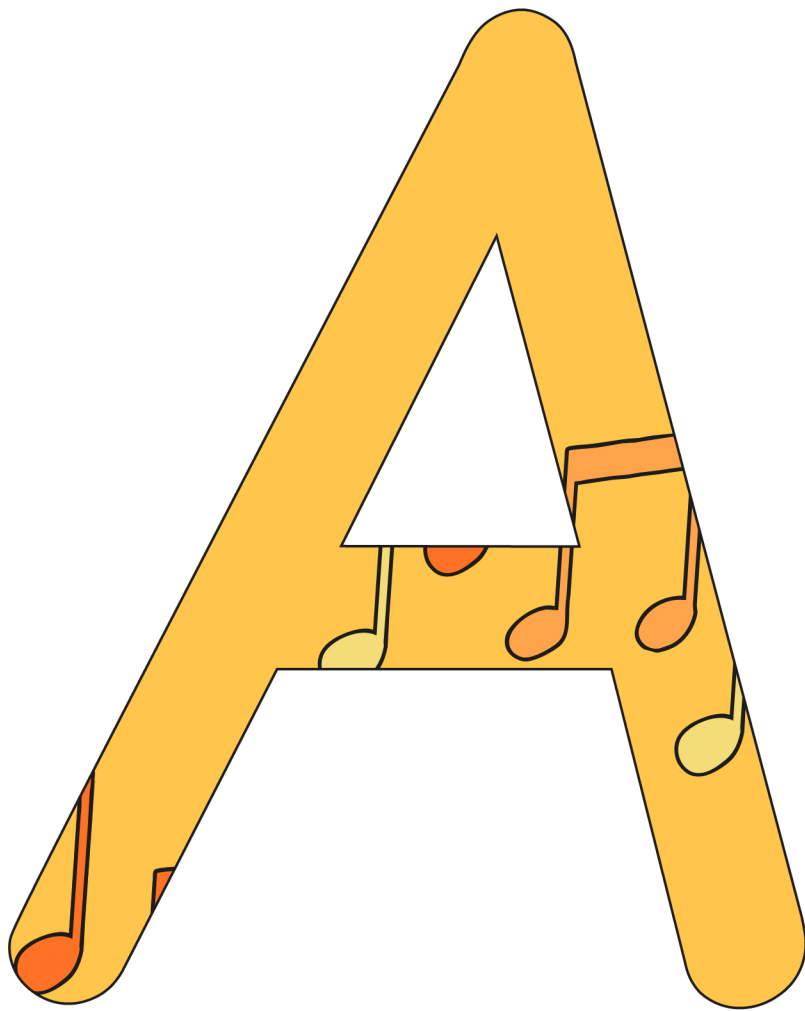

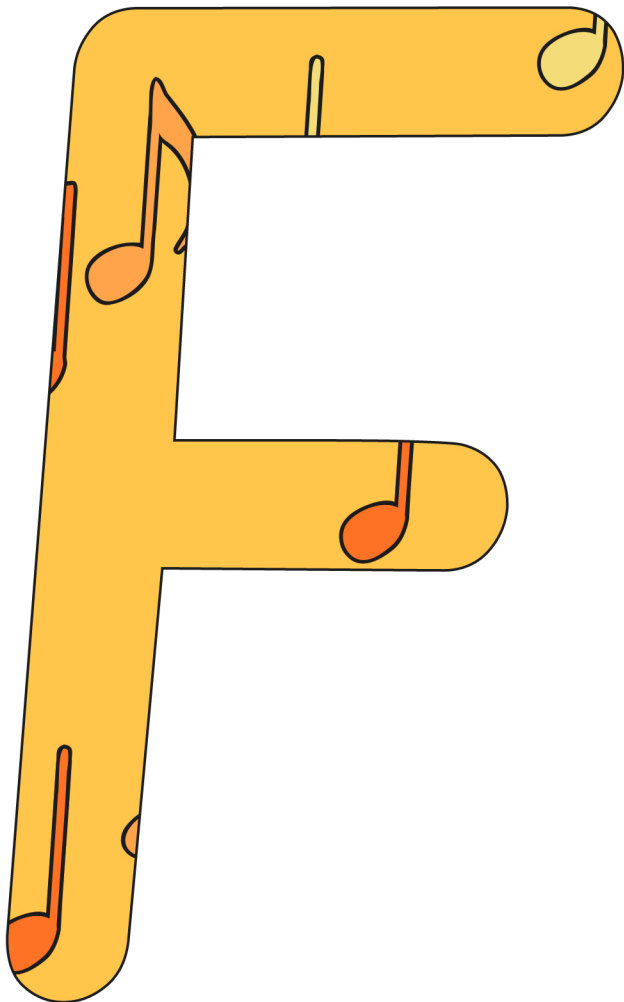
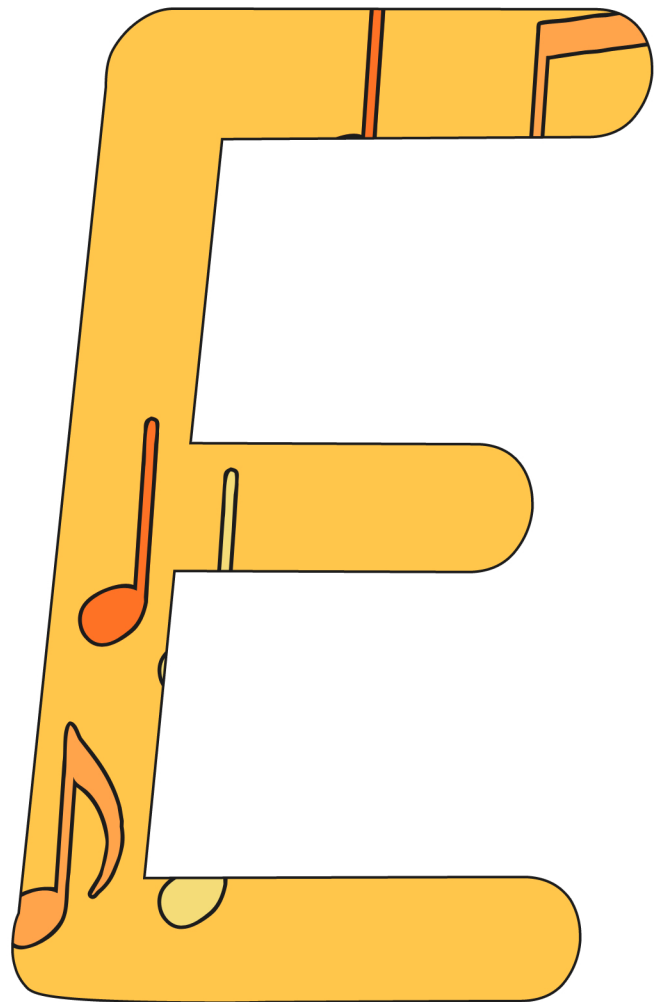
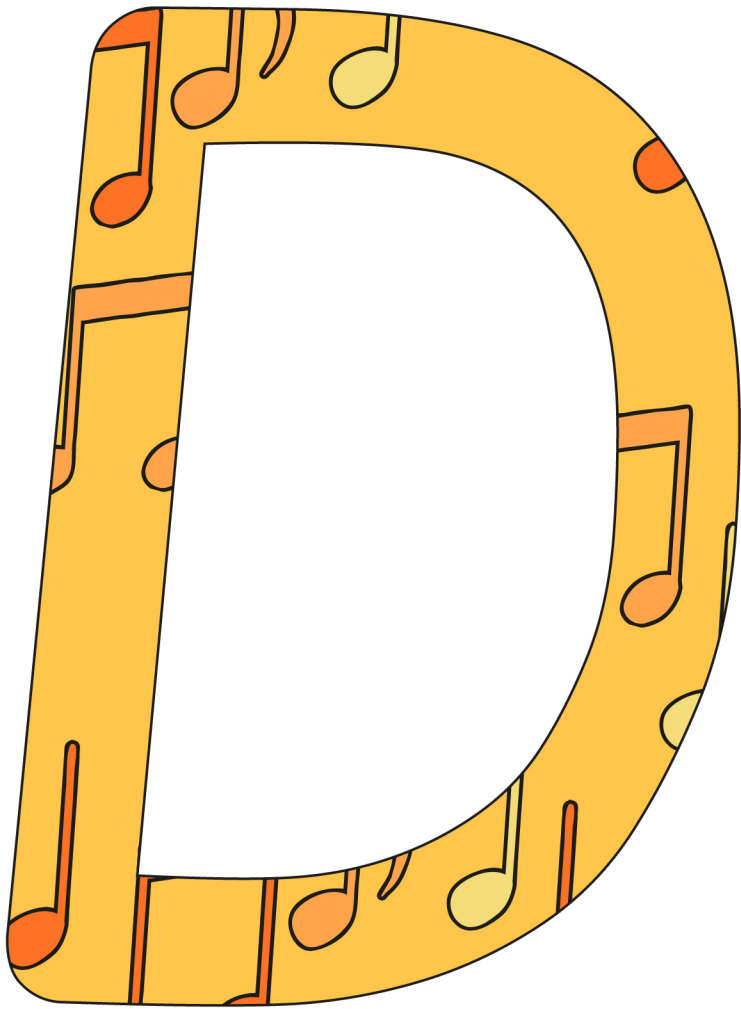

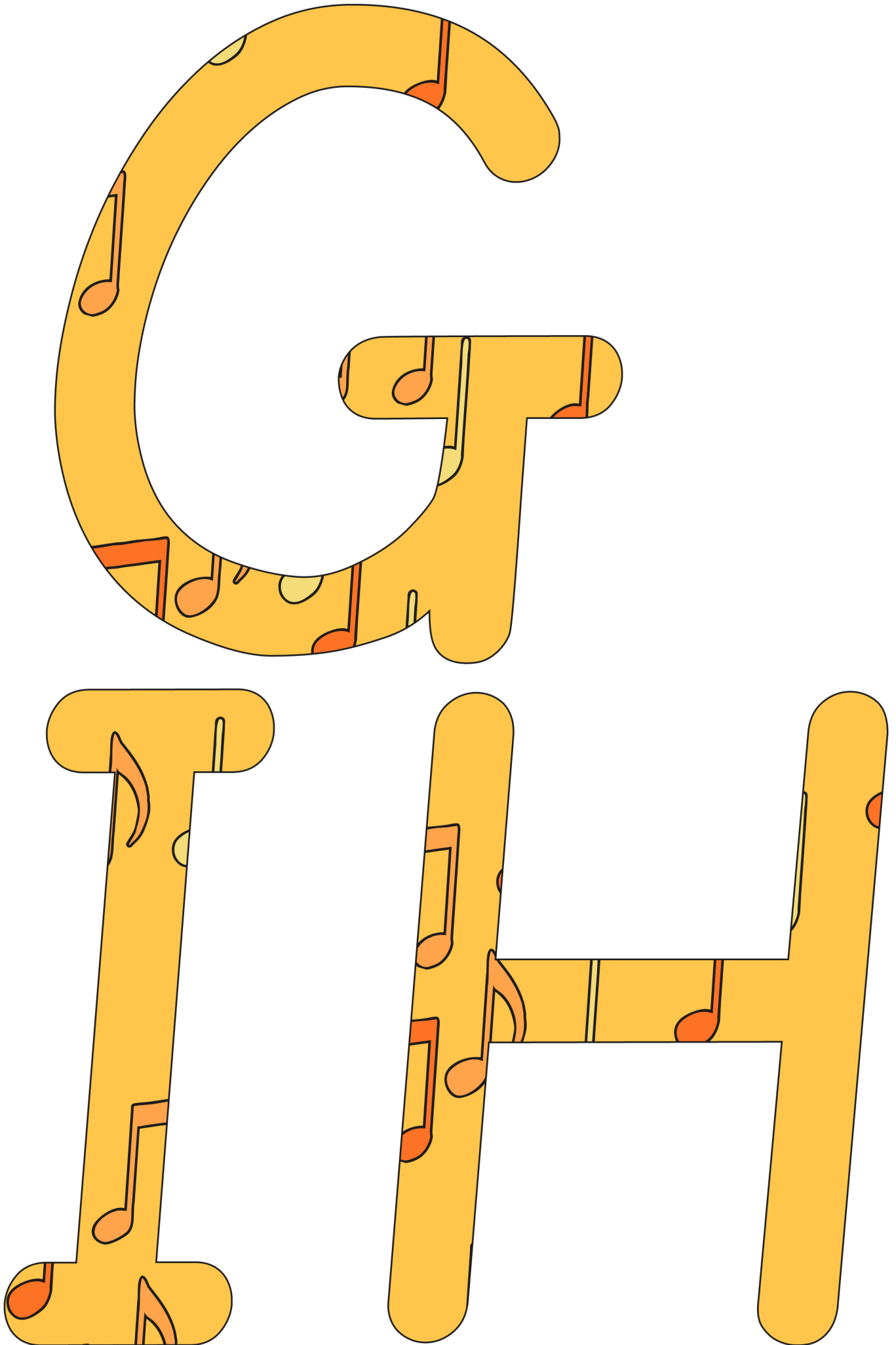

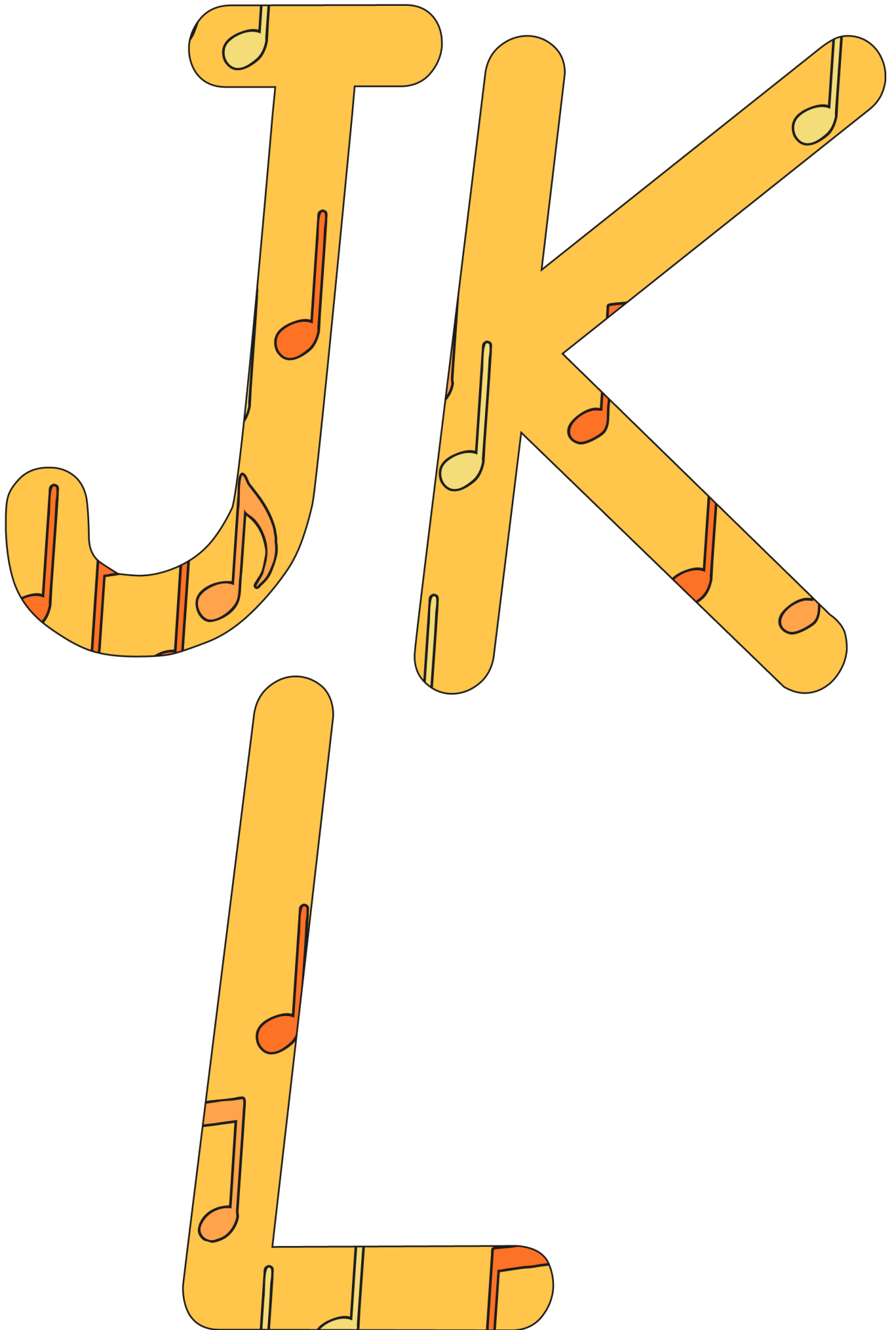

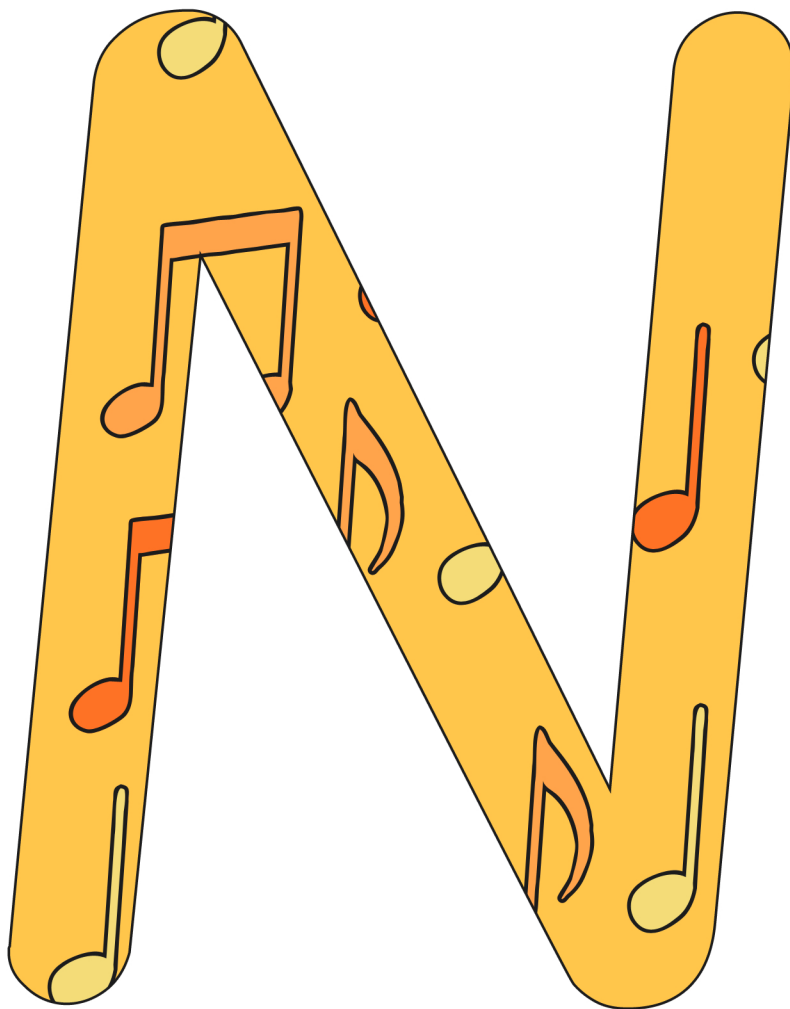
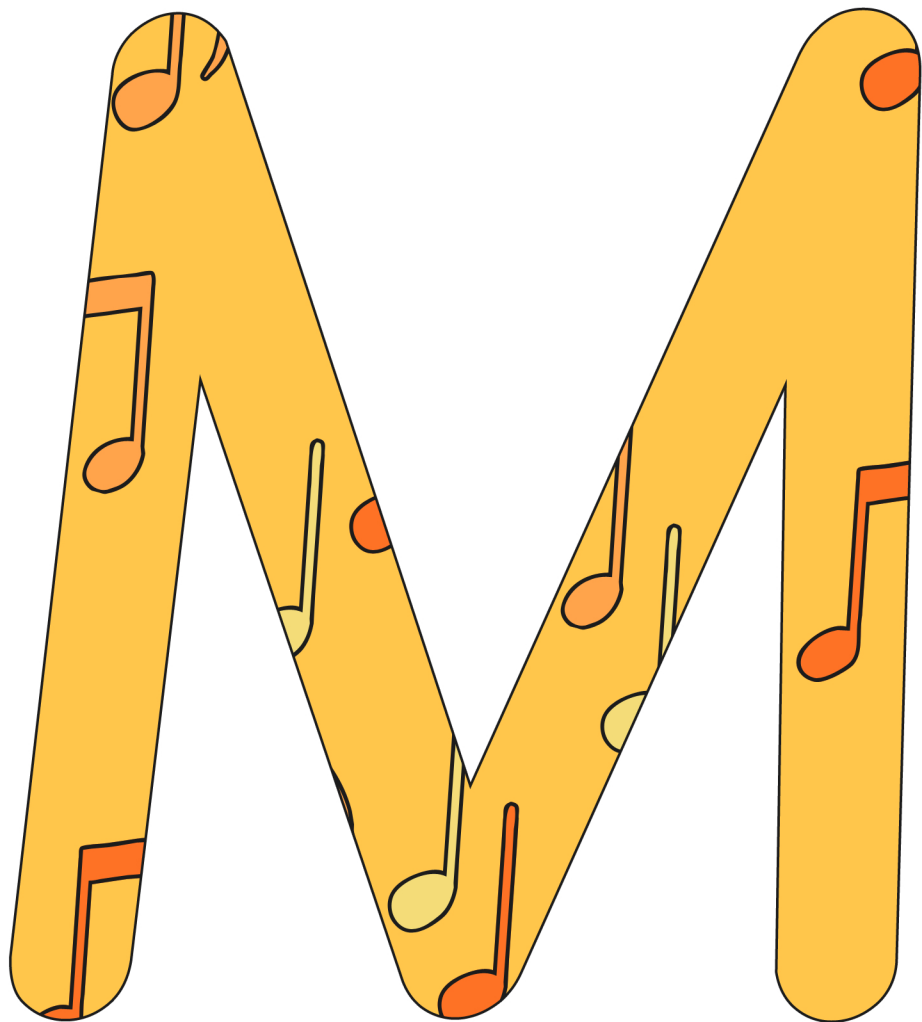

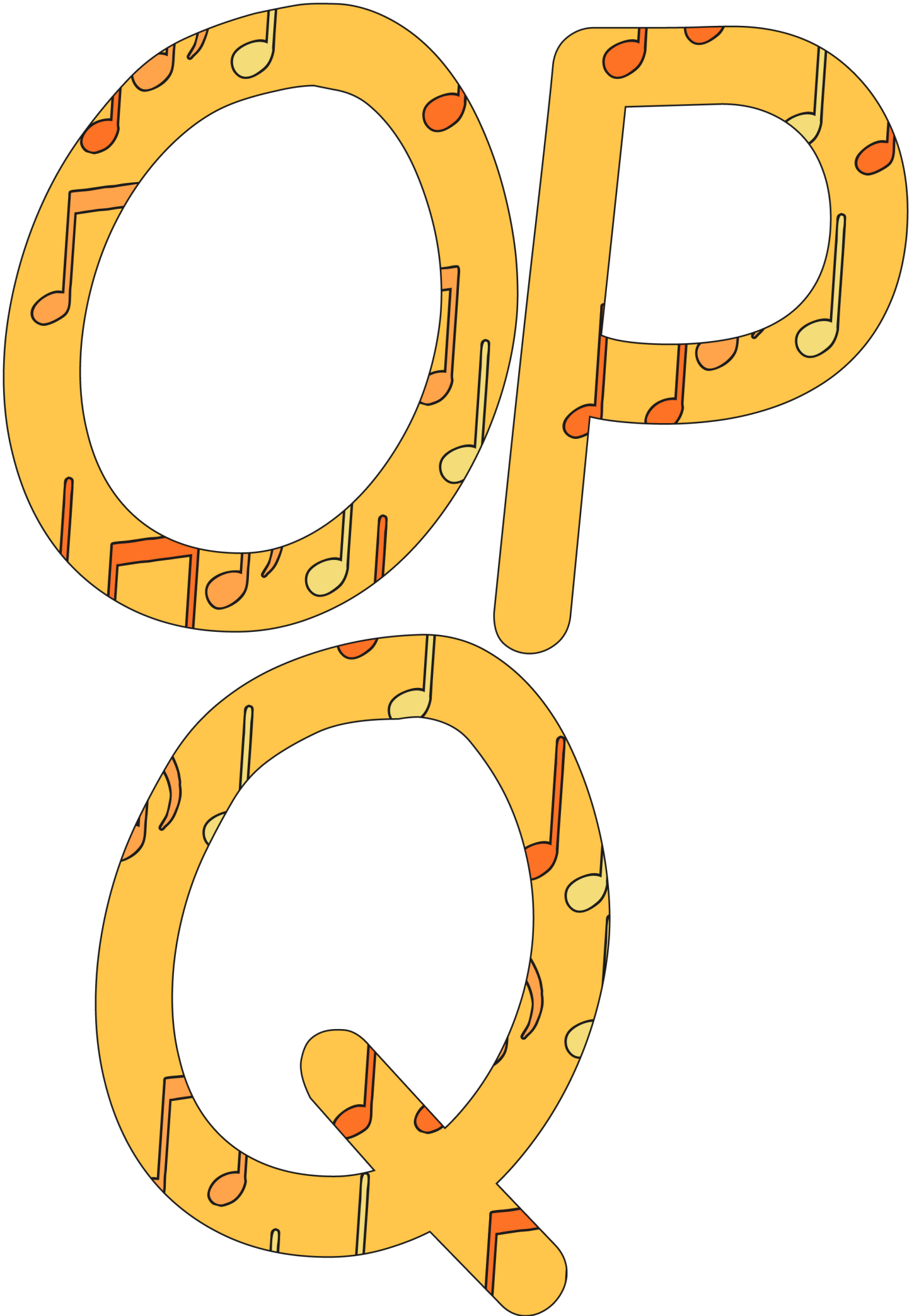

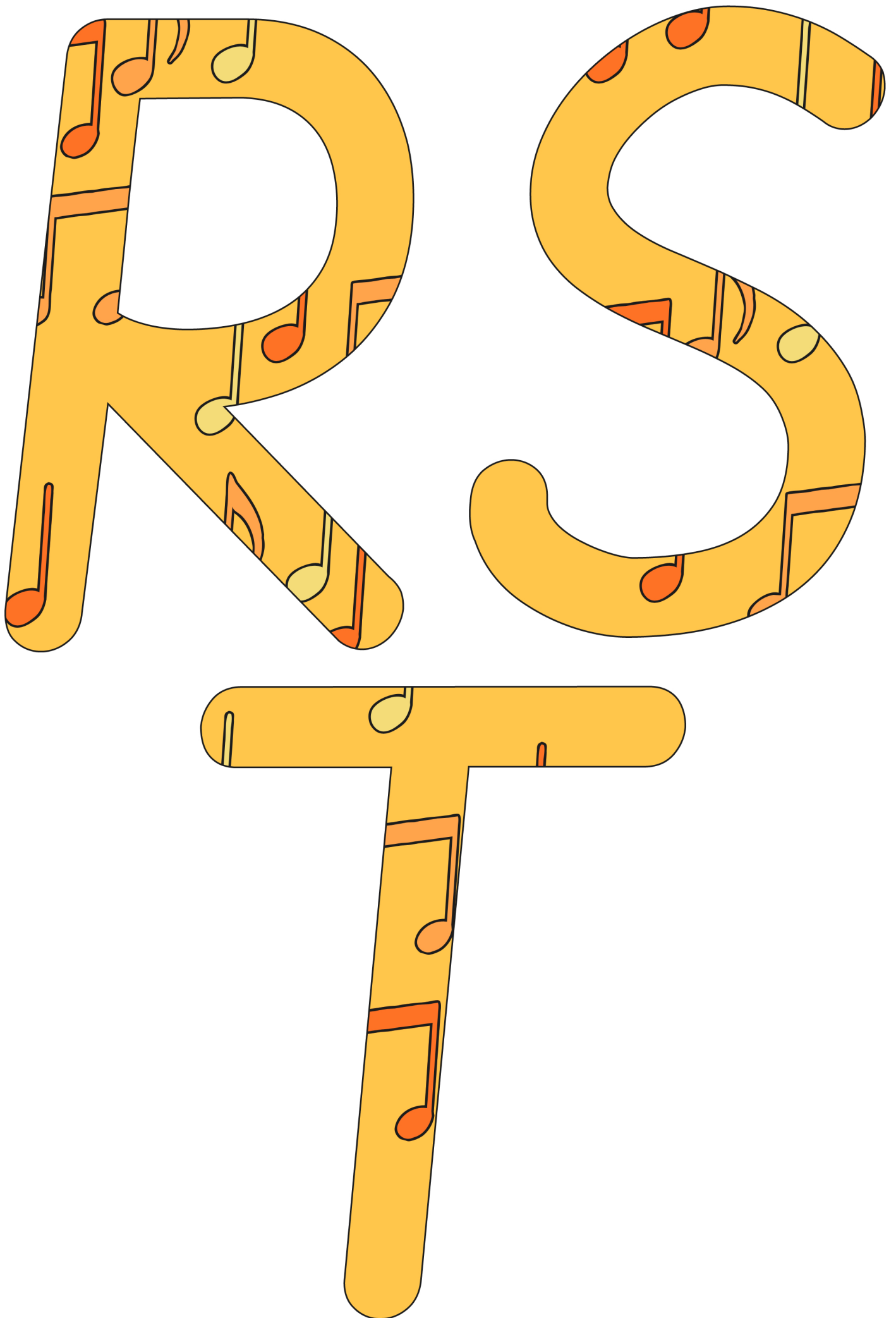

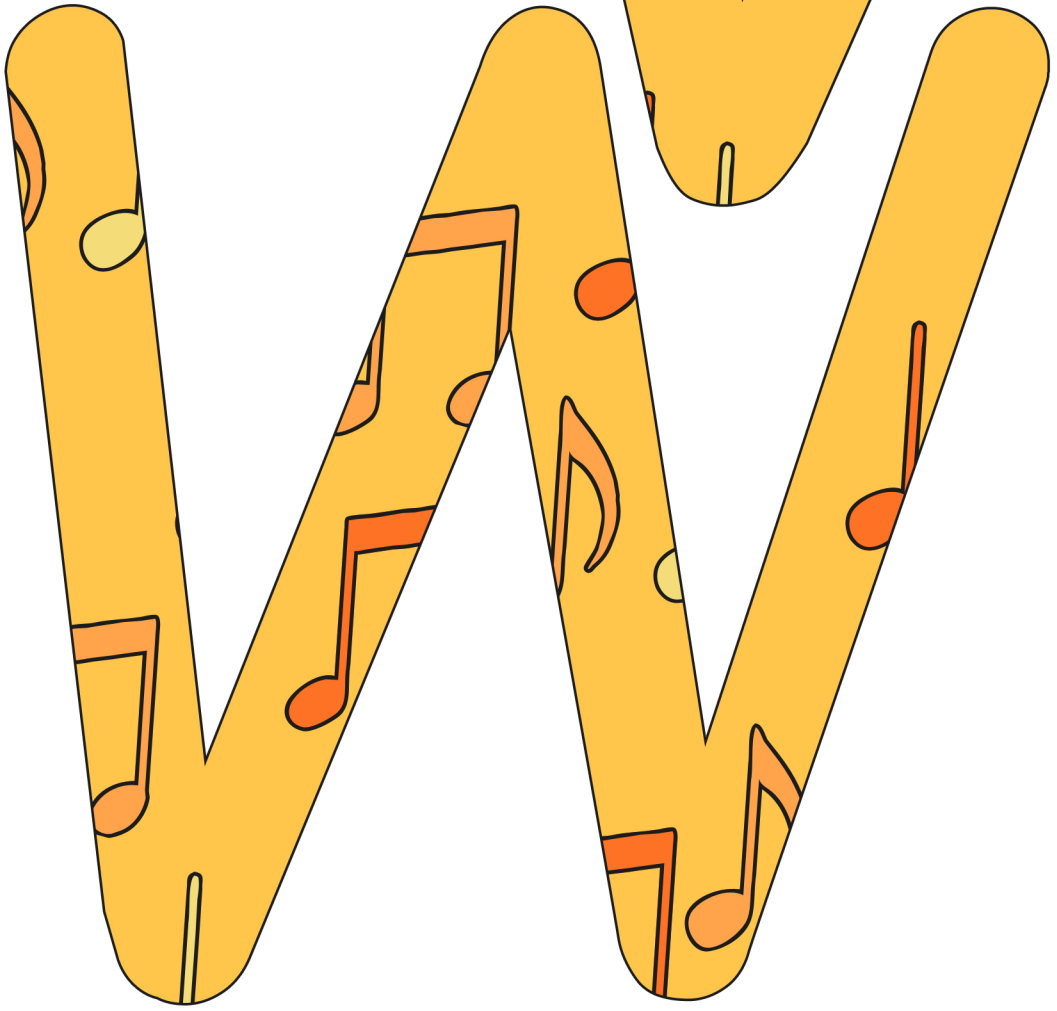
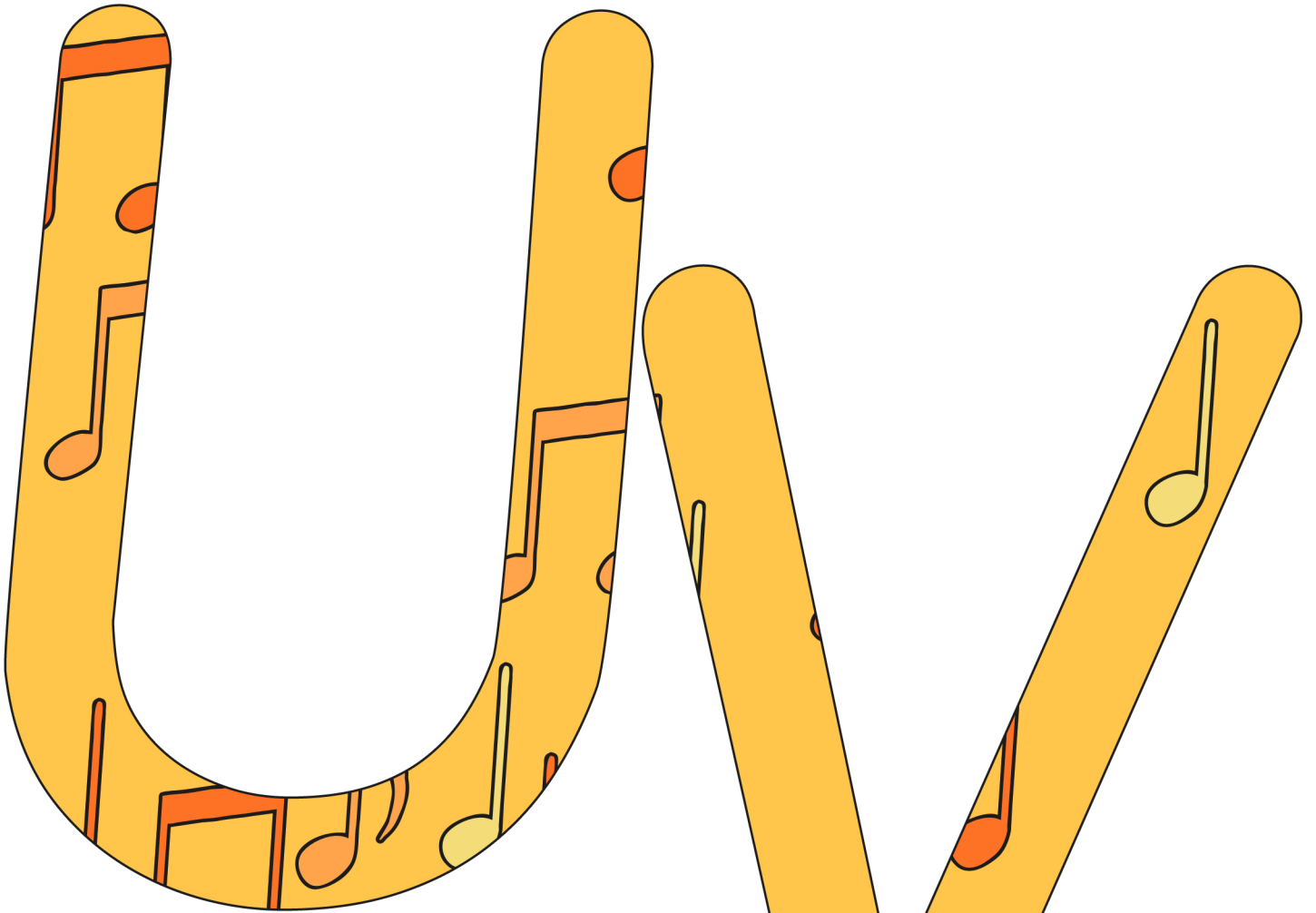

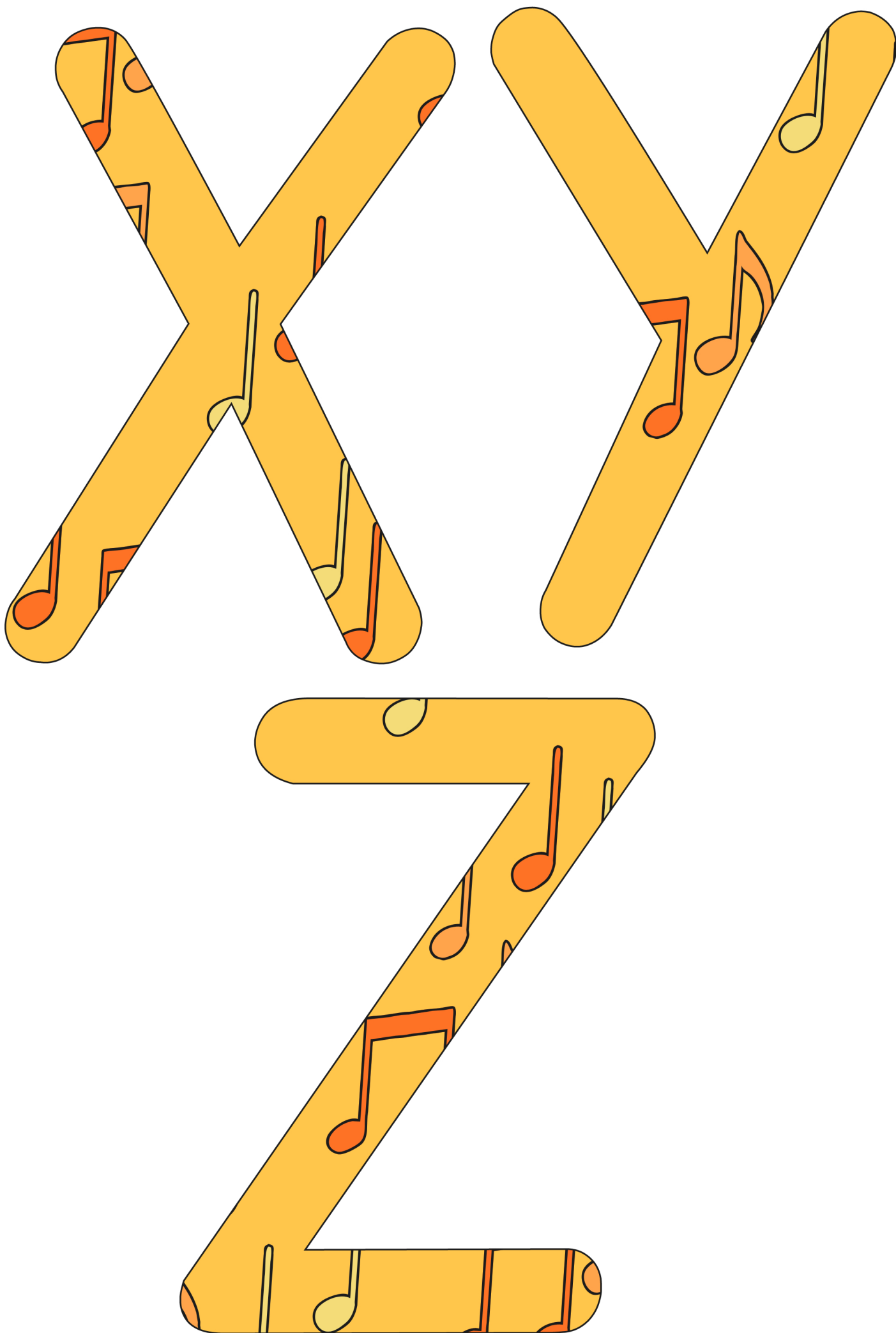

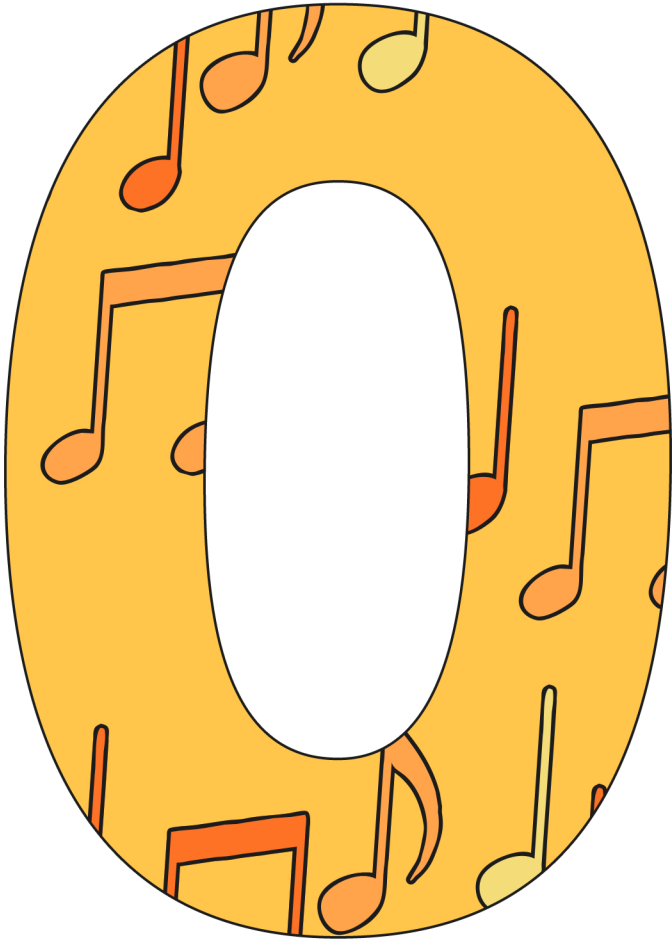

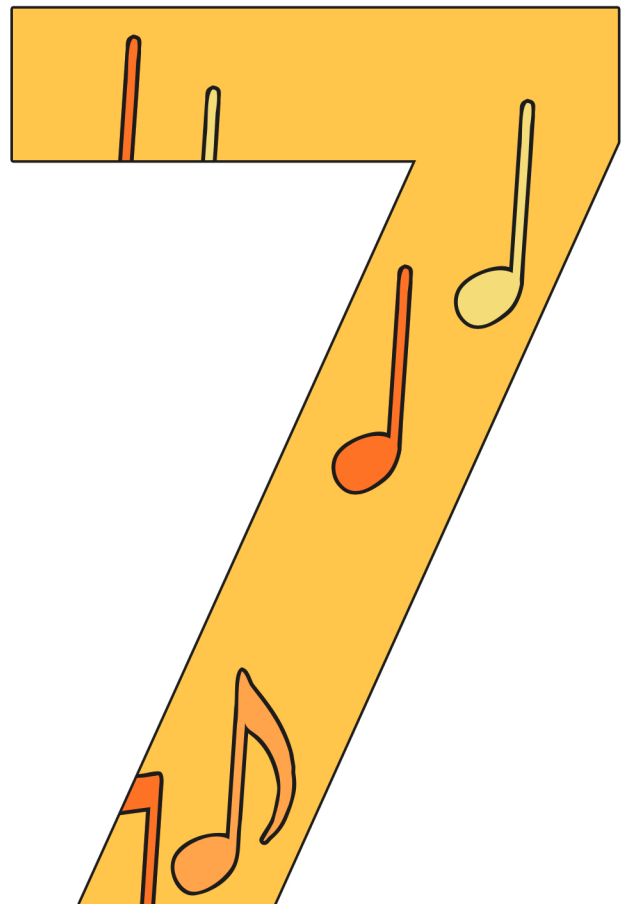
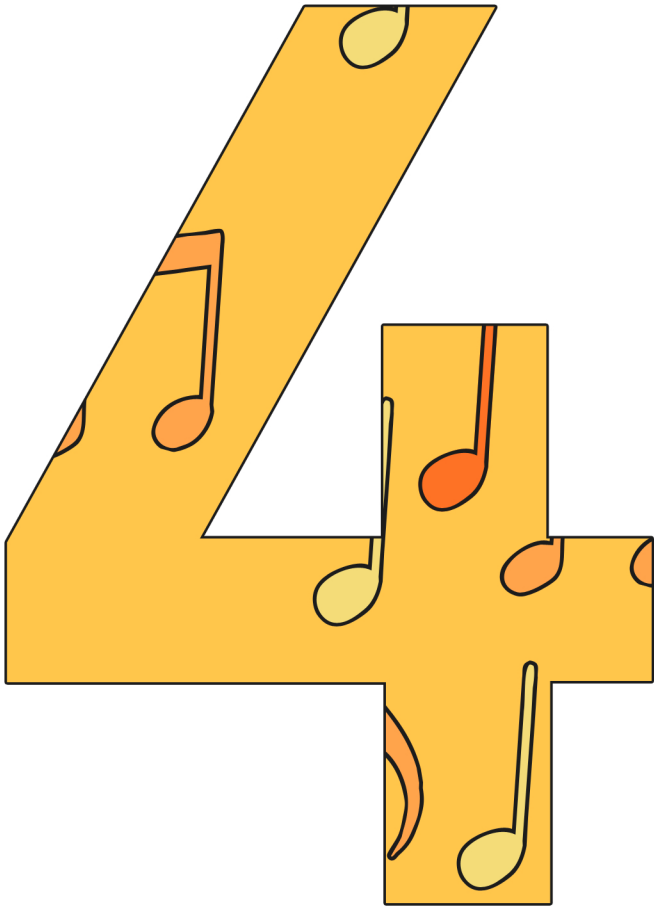

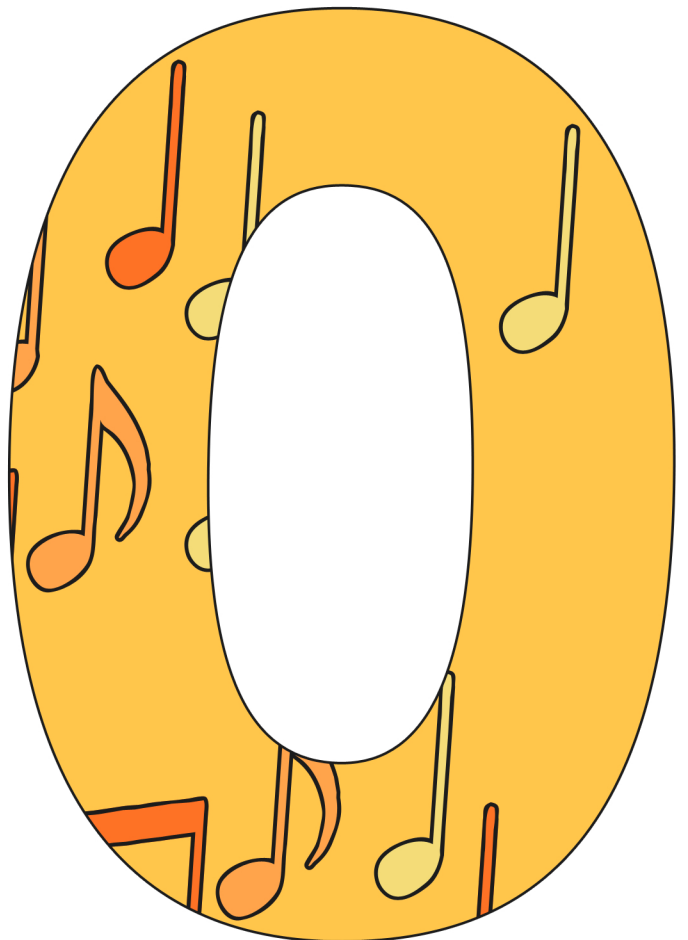
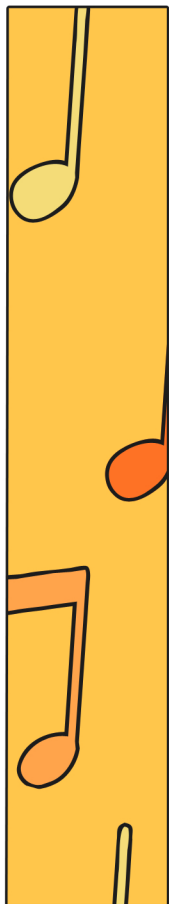
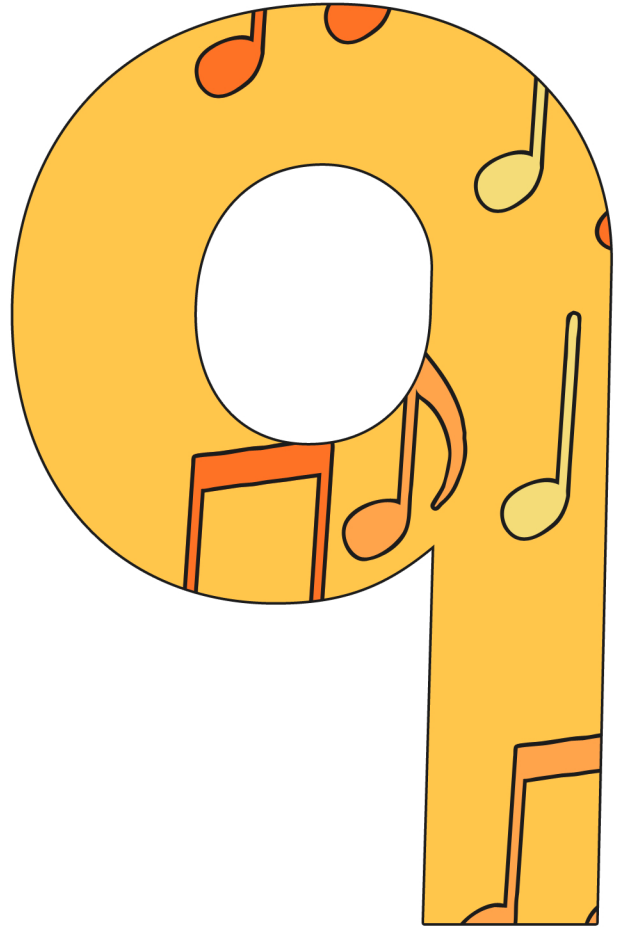
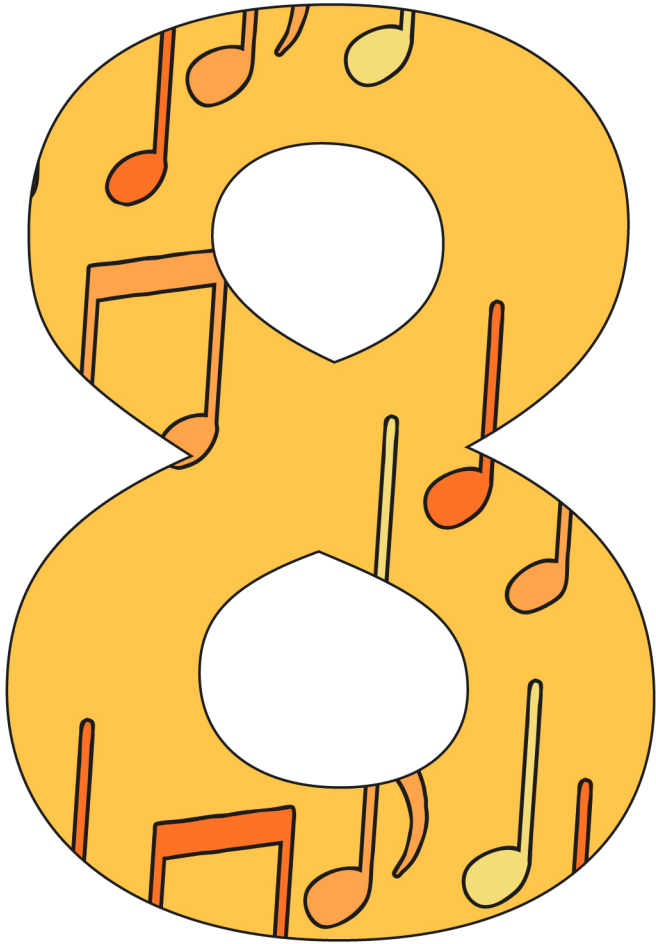

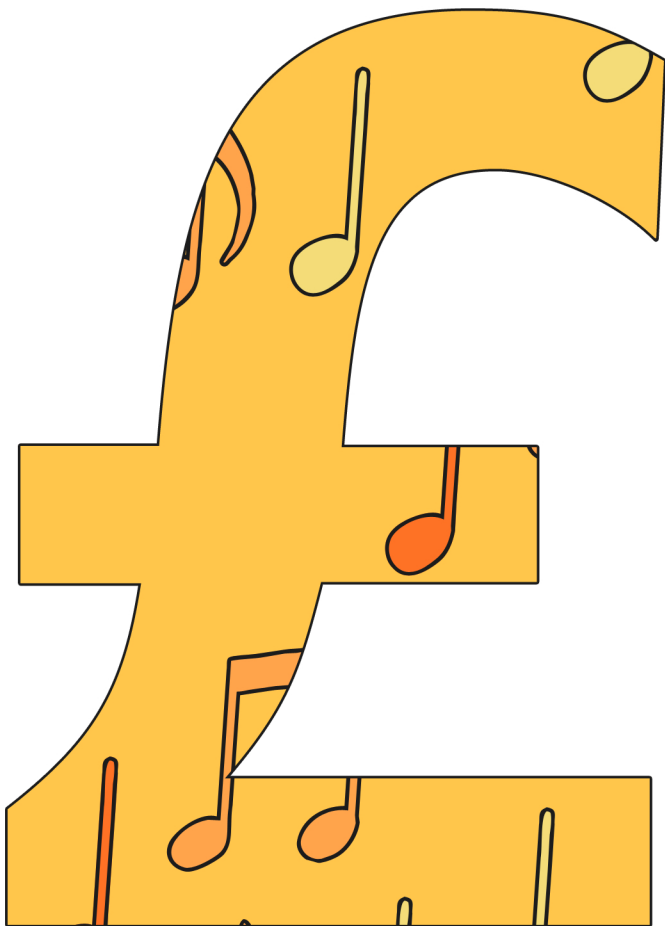
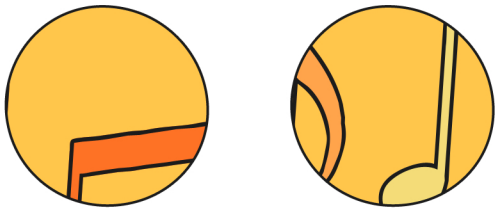
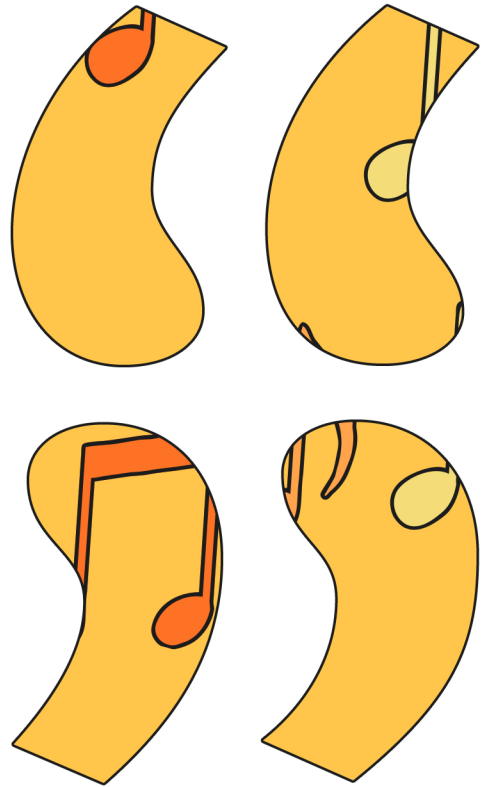

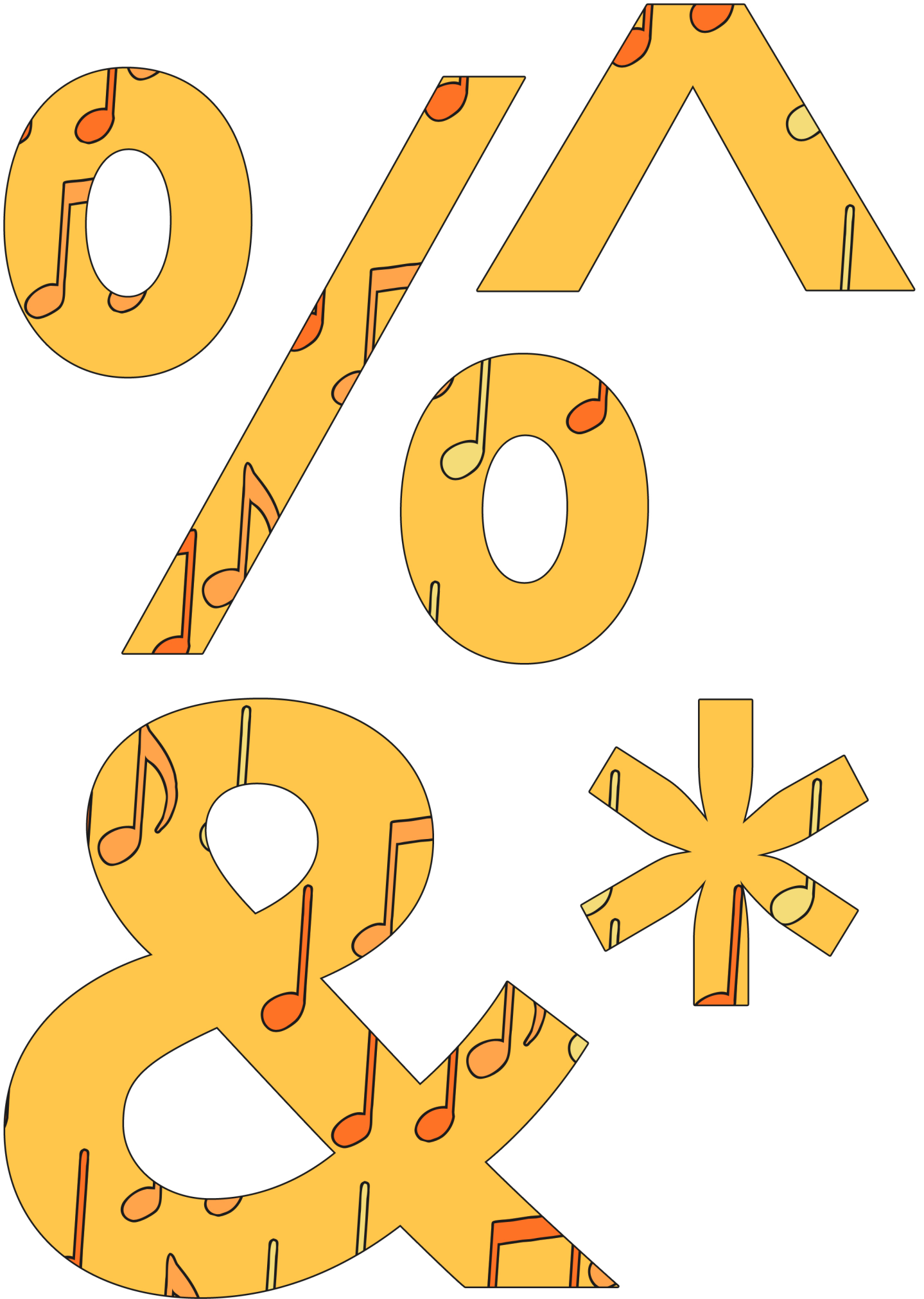

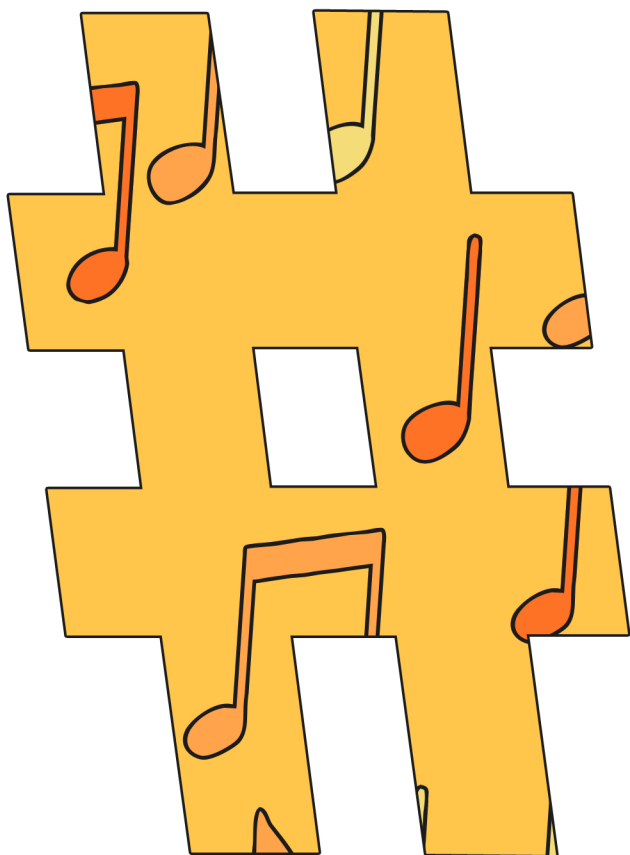
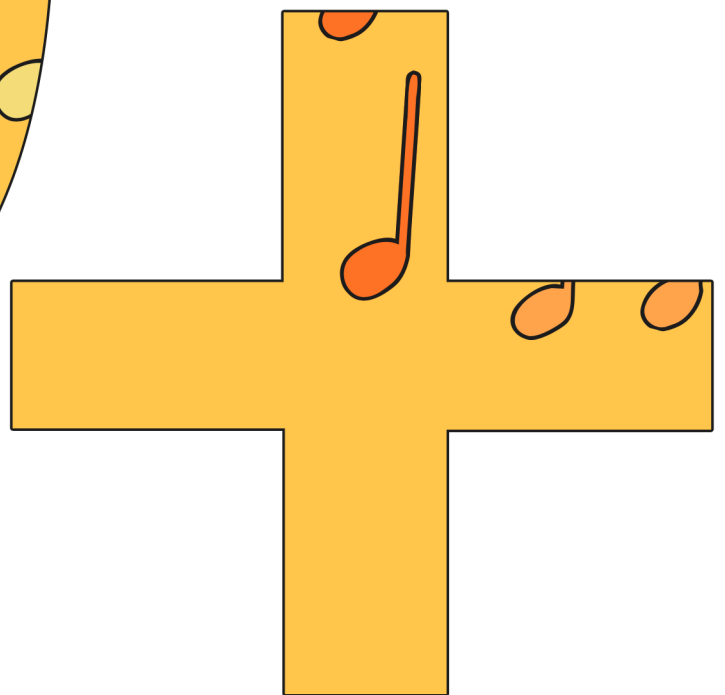
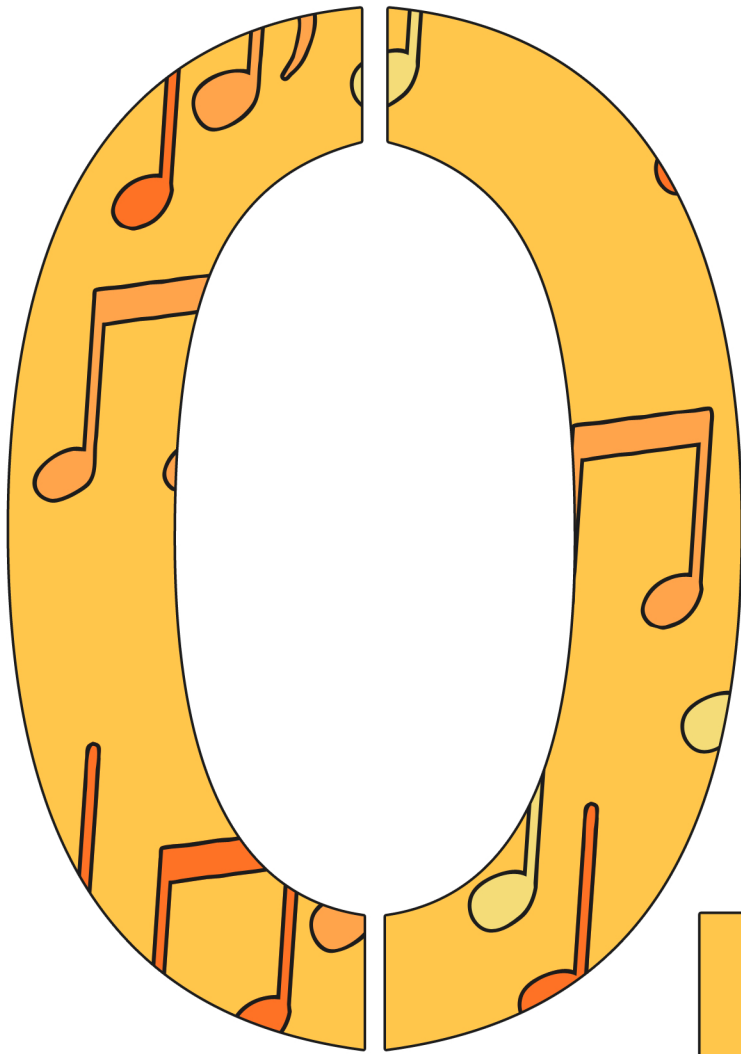

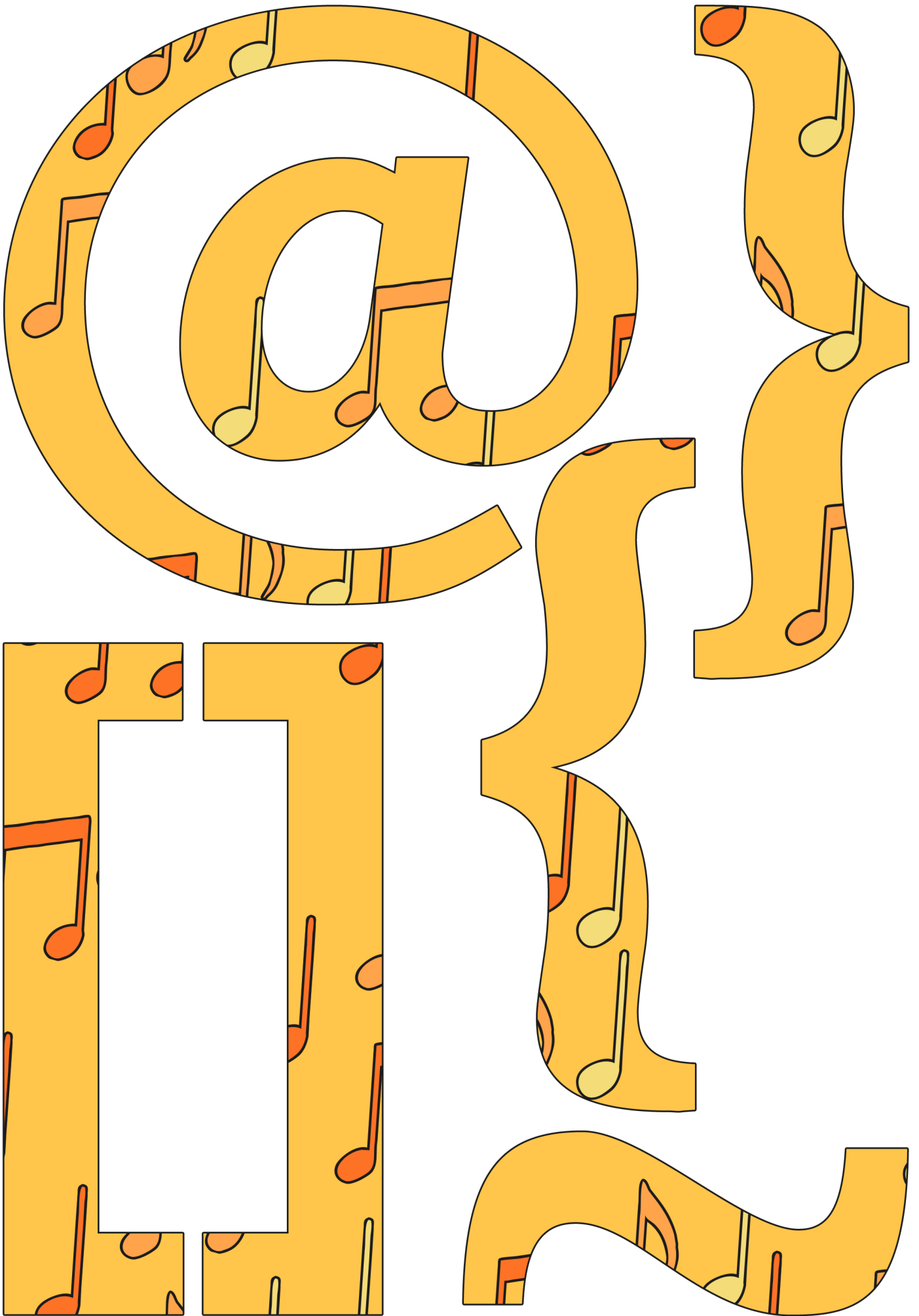

Radio S

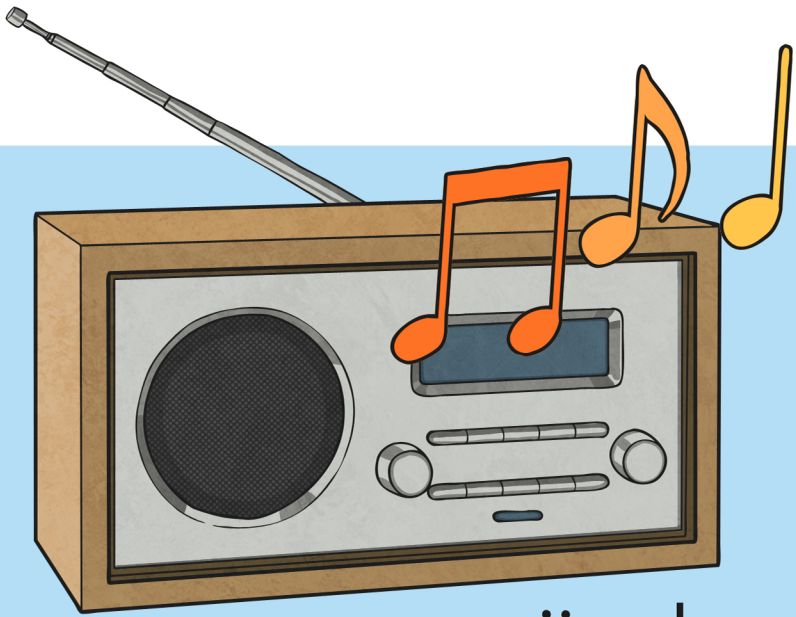

jingle

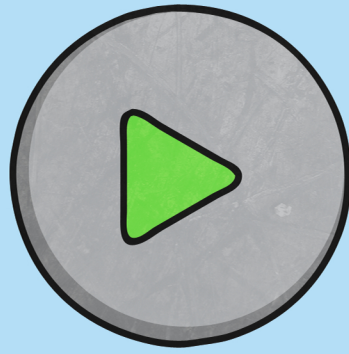

play

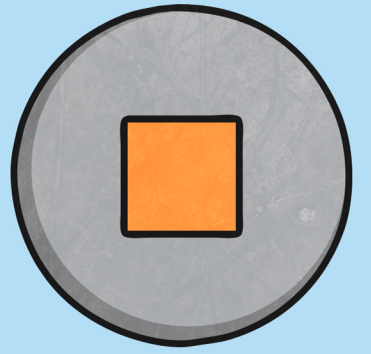

stop



edit

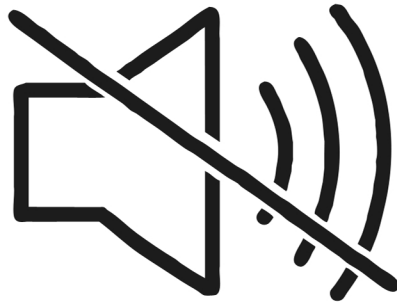

mute



podcast



voiceover

backing track

Station

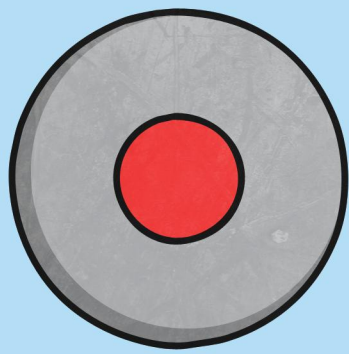

record



skip



digital content

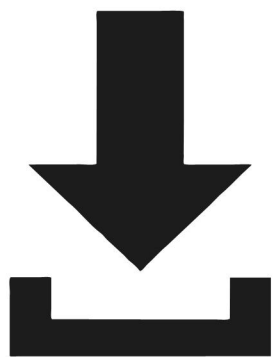

download

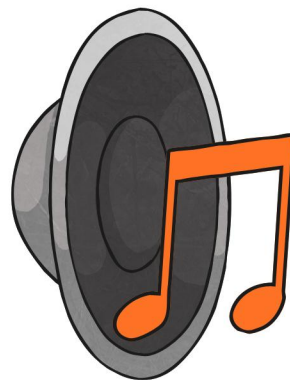

audio

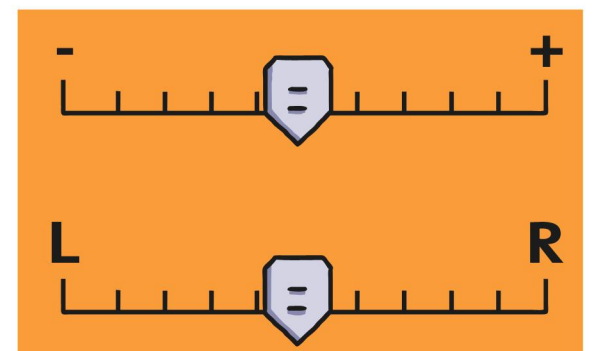

gain

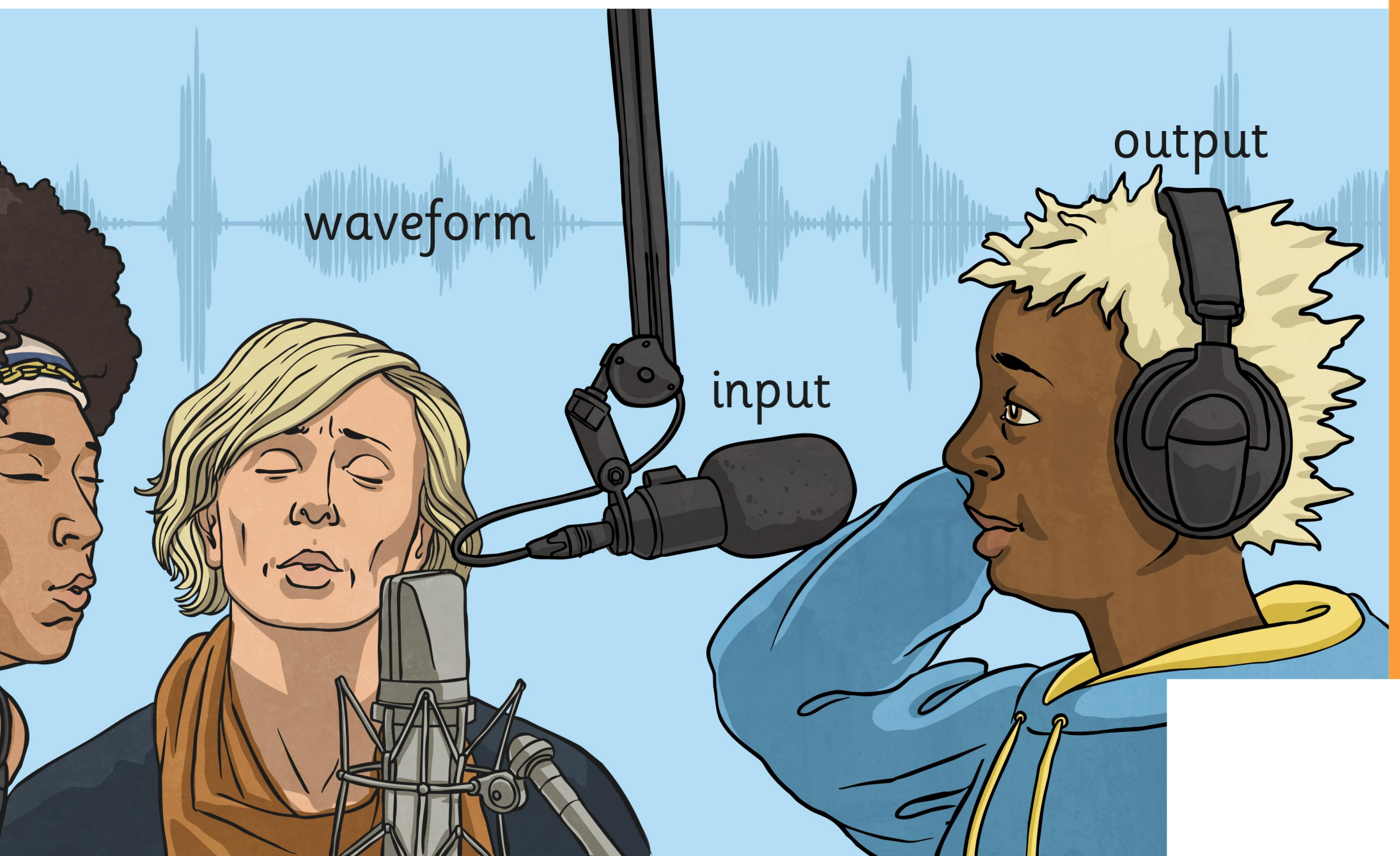

Radio S

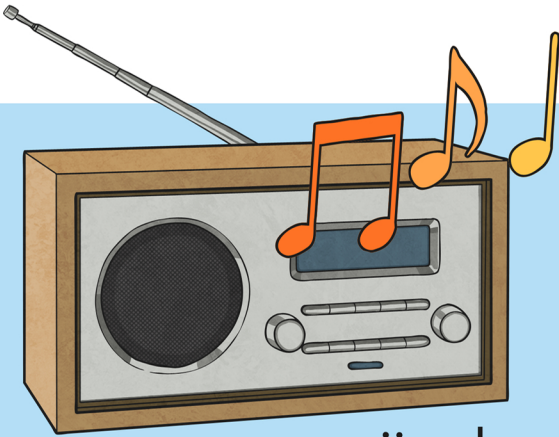

jingle

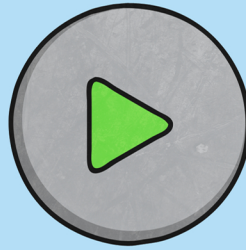

play

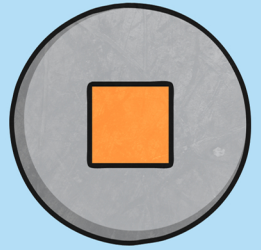

stop

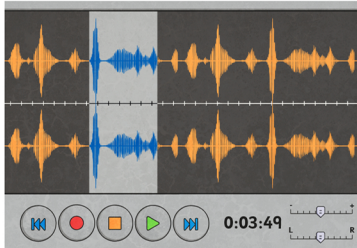

edit

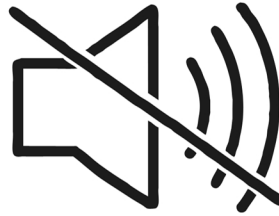

mute



podcast



voiceover

backing track

Station

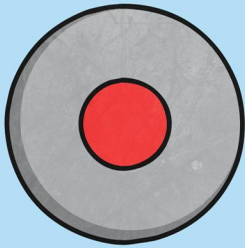

record



skip



digital content

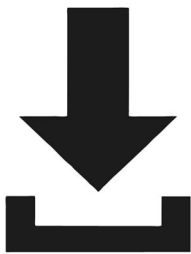

download



audio

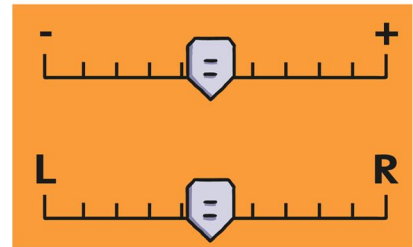

gain

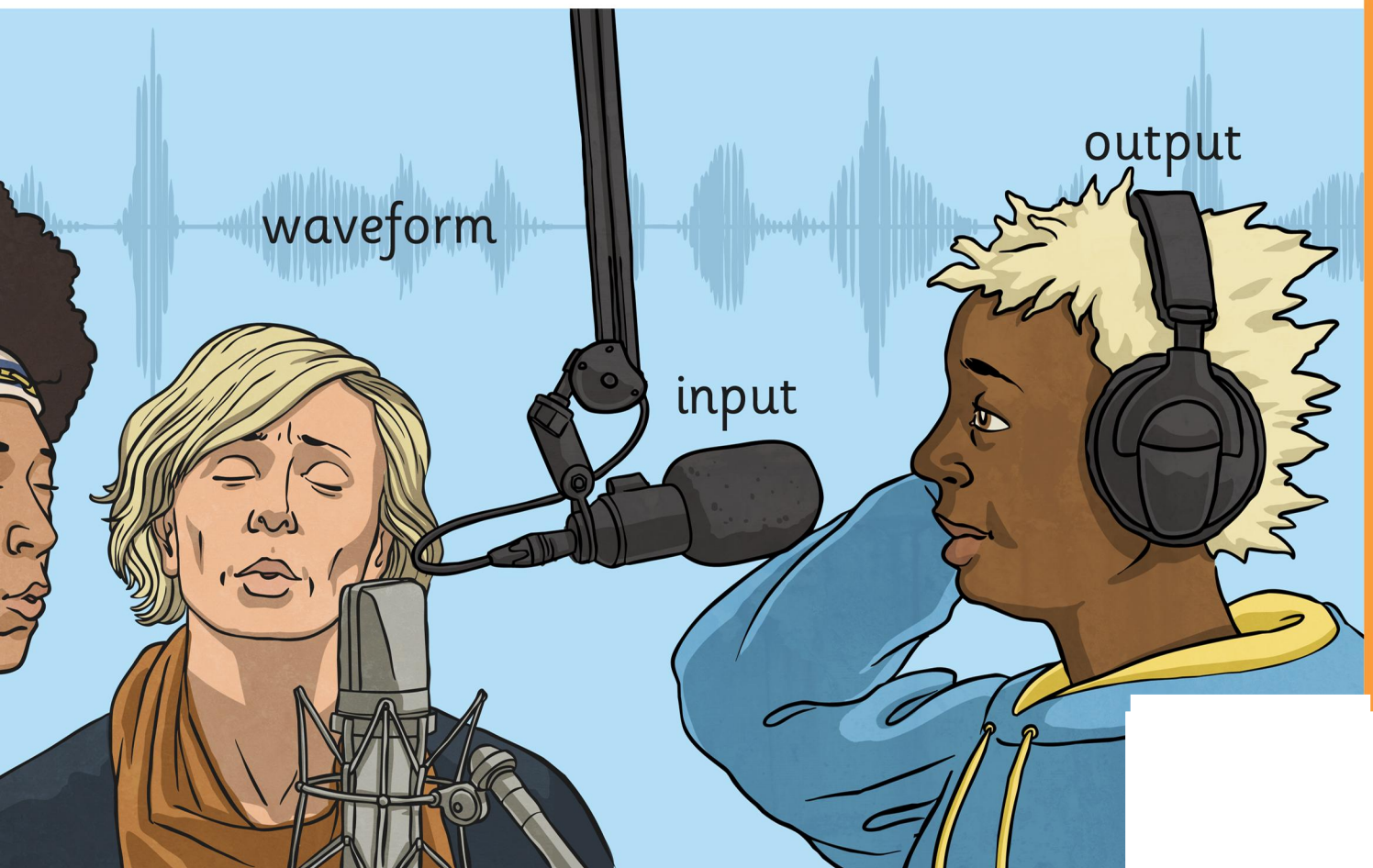

Radio S

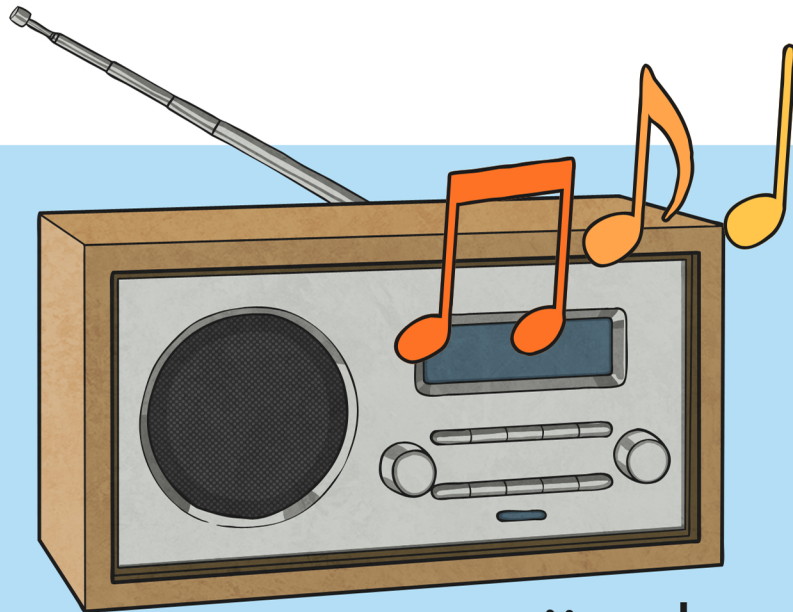

jingle

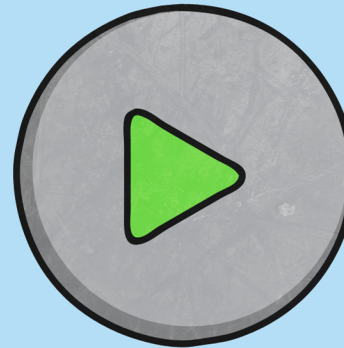

play

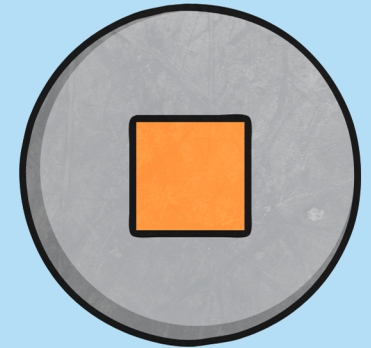

stop

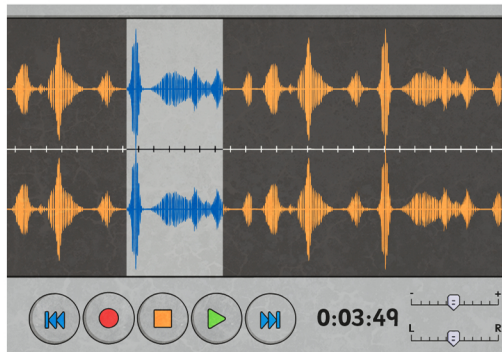

edit

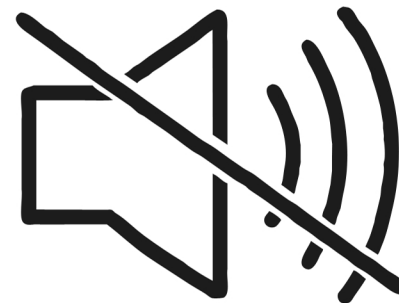

mute



podcast

Station

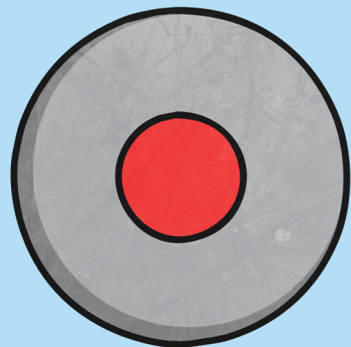

record



skip



digital content

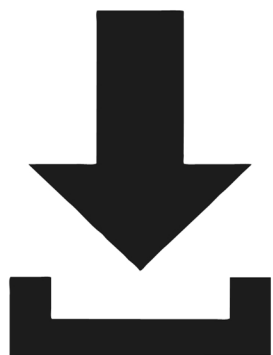

download

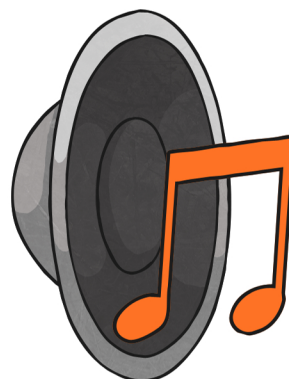

audio

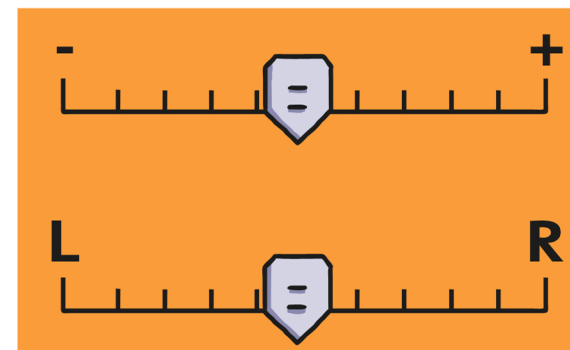

gain

edit

mute

podcast



voiceover

backing track

download

audio

gain

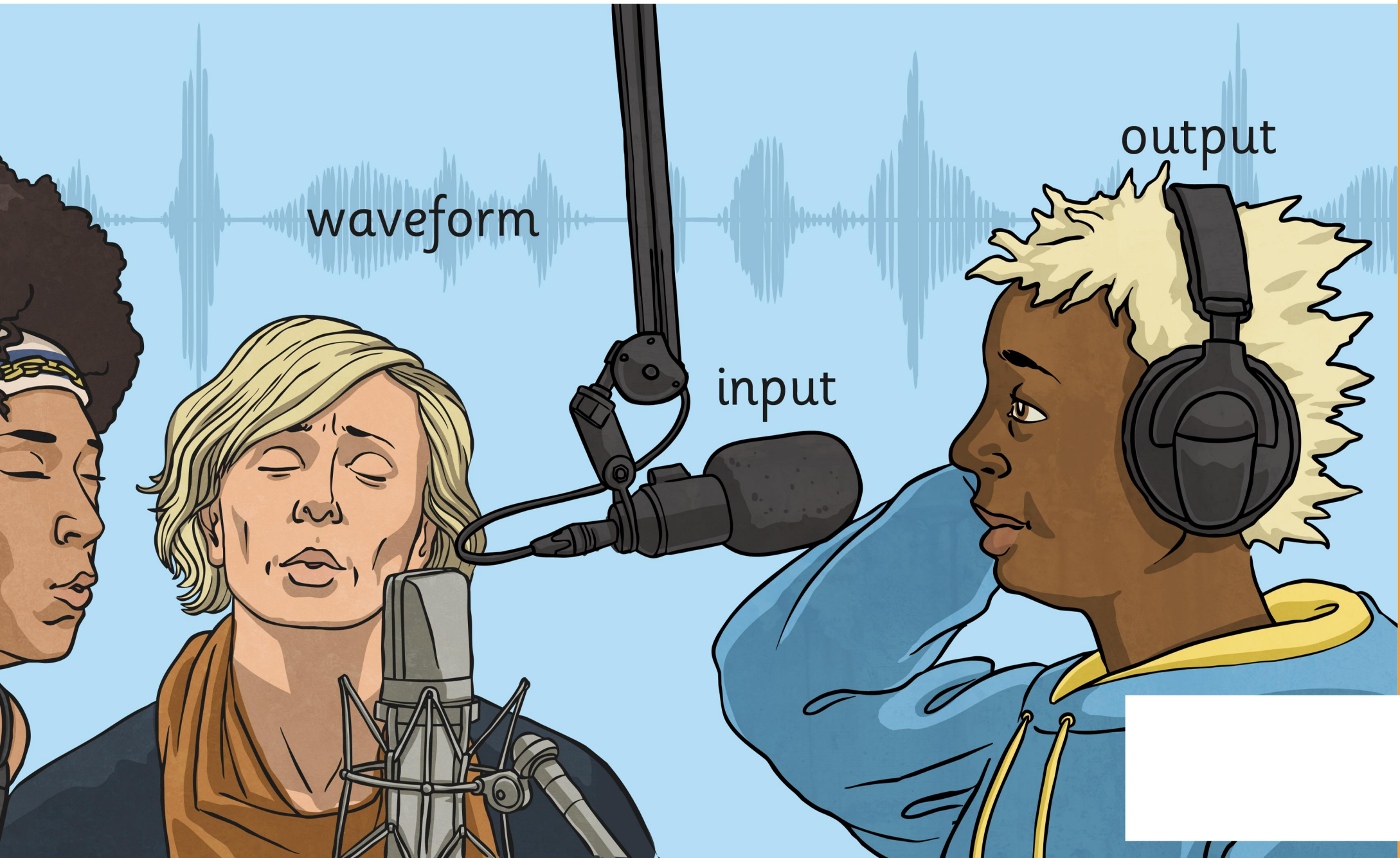

waveform

input

output

Radio Station



jingle

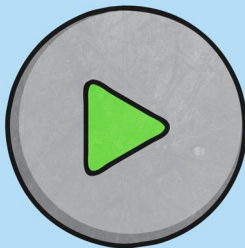

play

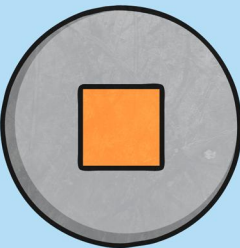

stop

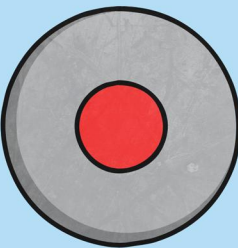

record



skip



digital content



edit

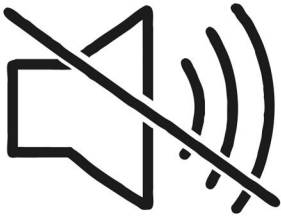

mute



podcast

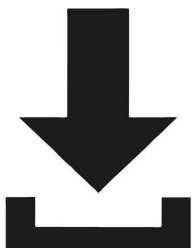

download



audio

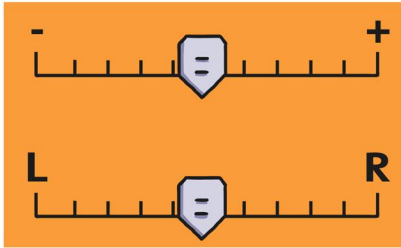

gain



Radio Station



jingle



play

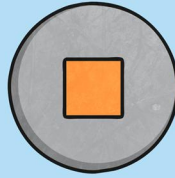

stop

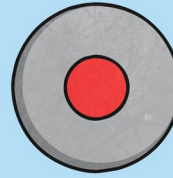

record



skip



digital content



edit



mute



podcast

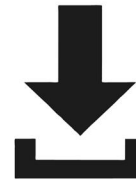

download



audio

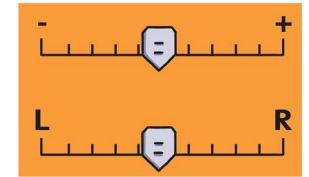

gain



play

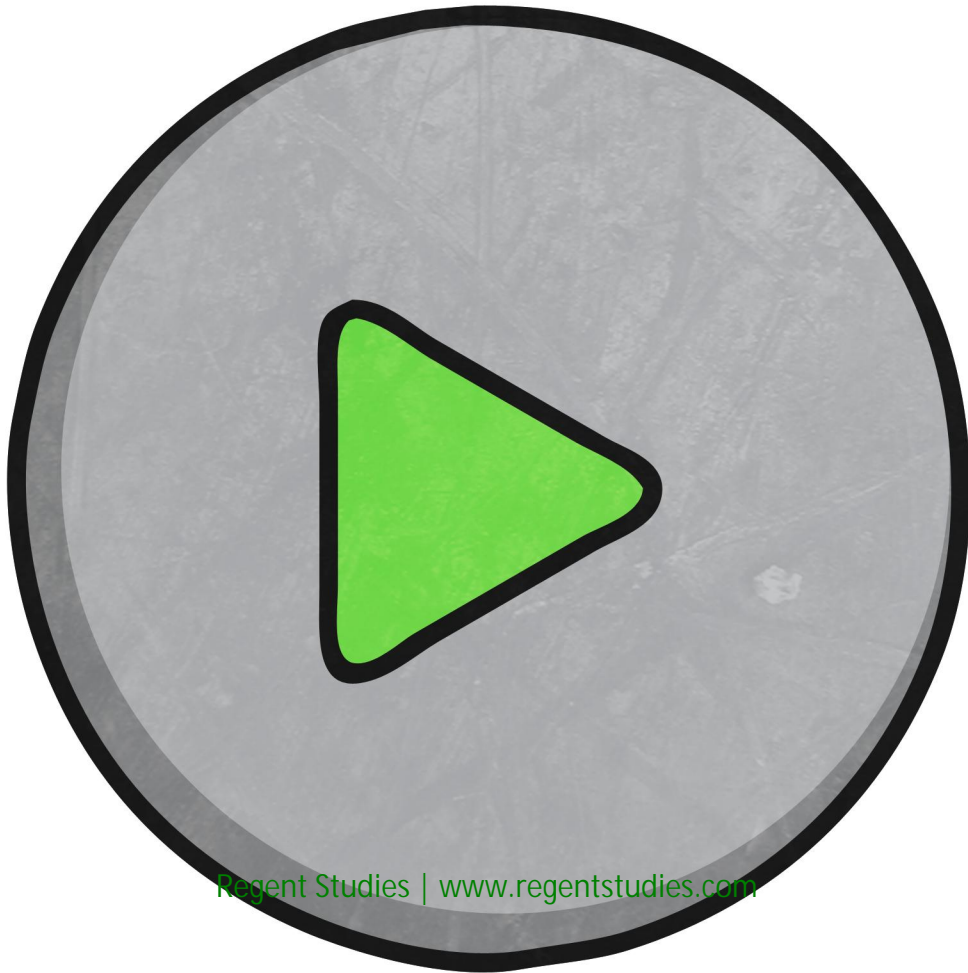

Regent Studies | www.regentstudies.com

stop

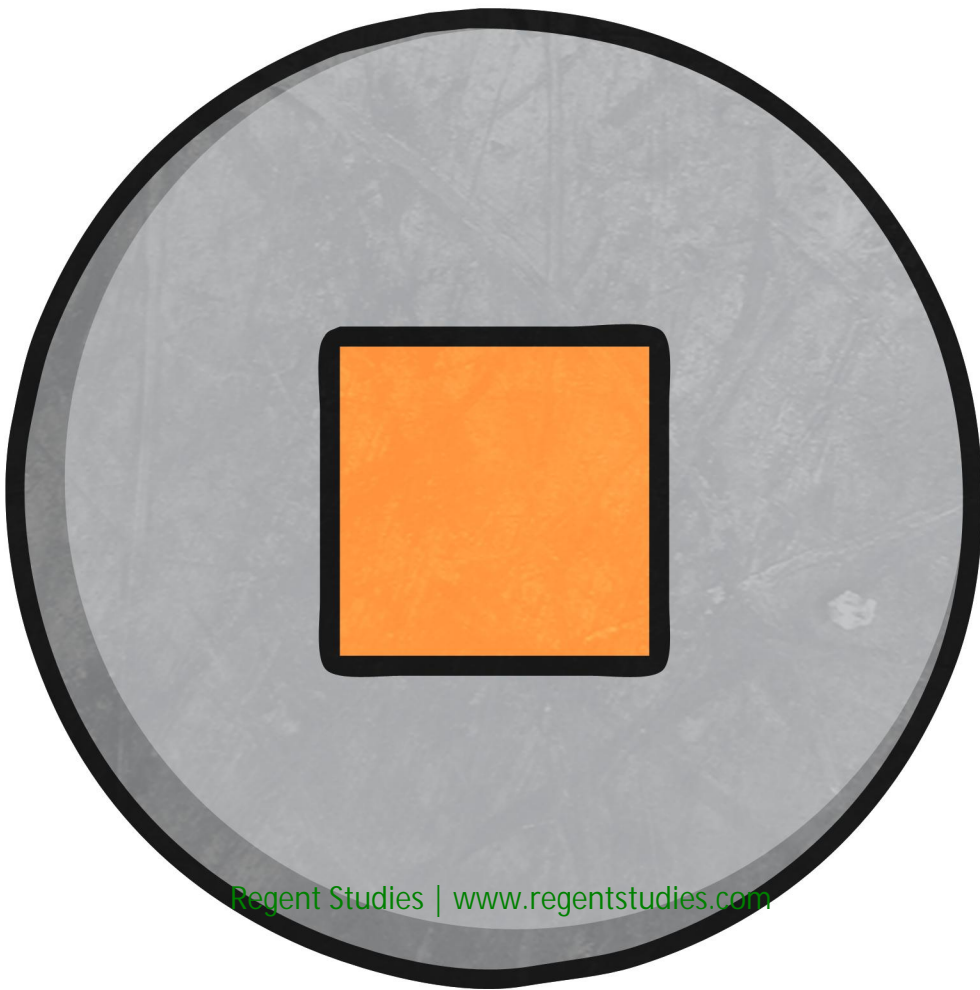

record

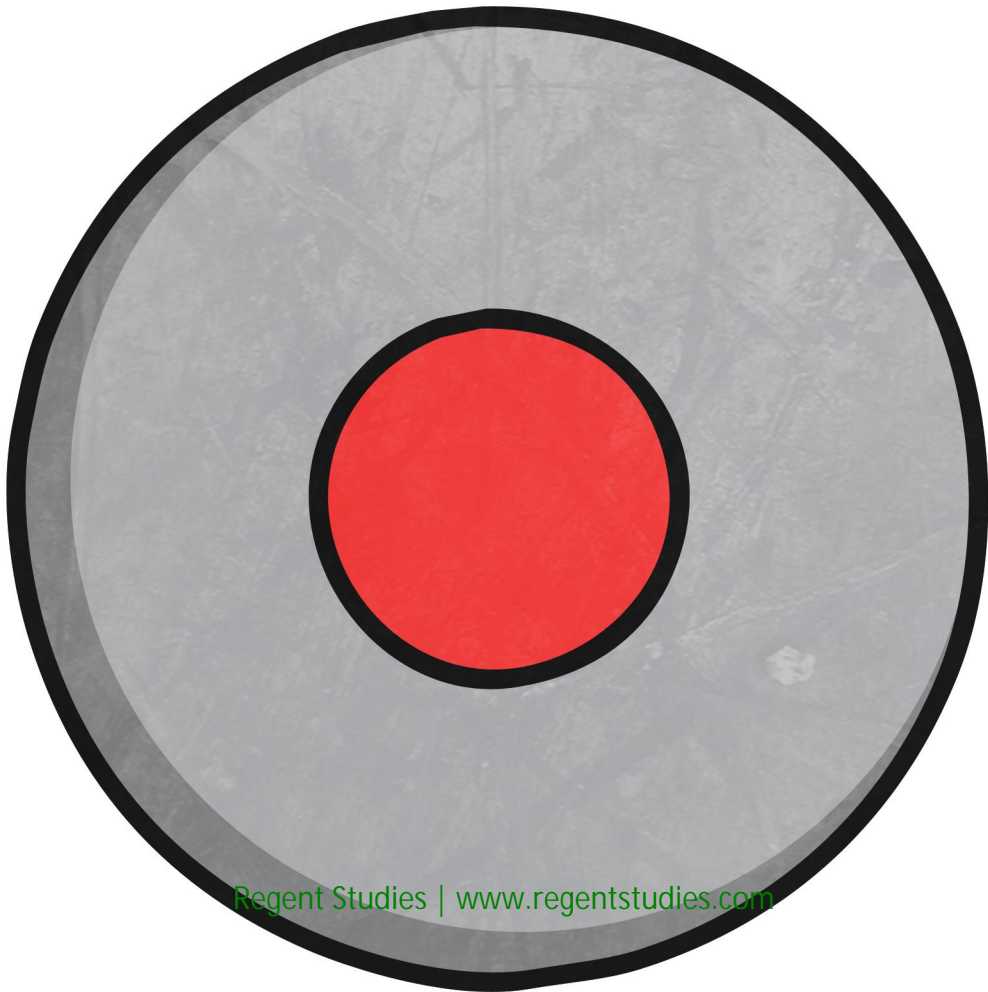

skip



digital content



Regent Studies | www.regentstudies.com

mute

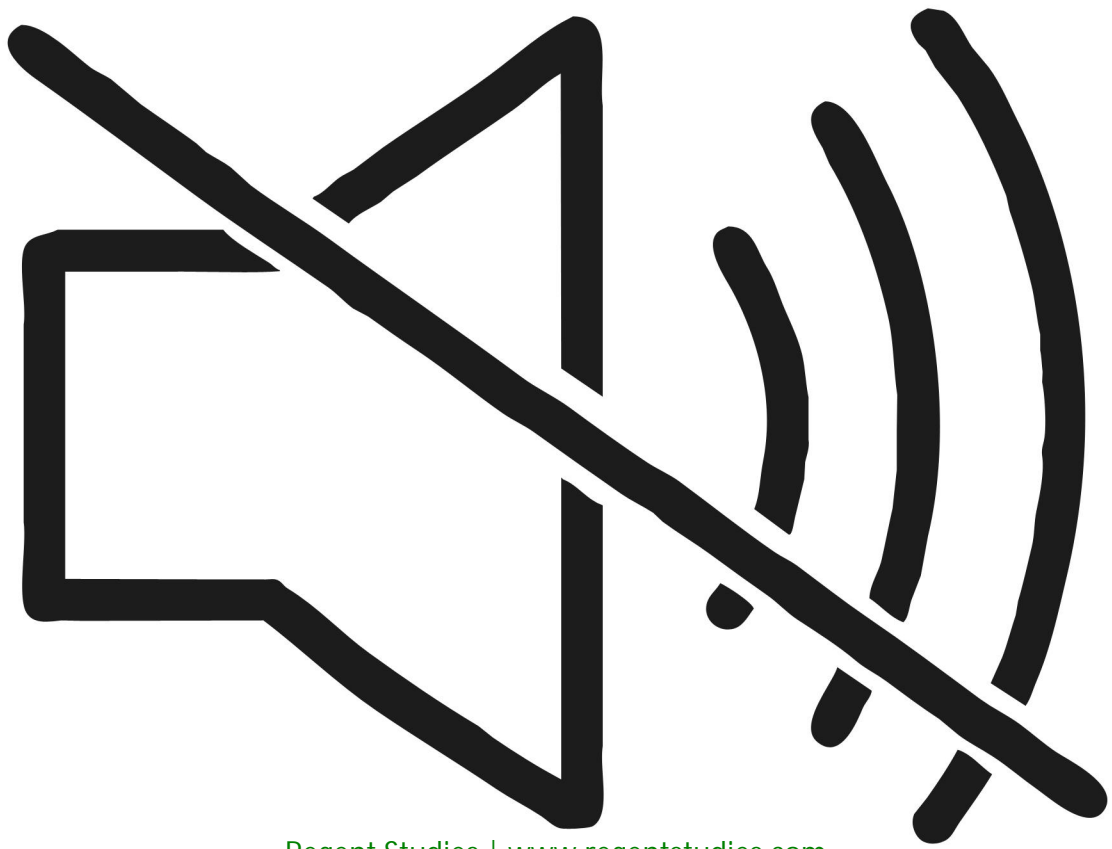

Regent Studies | www.regentstudies.com

gain

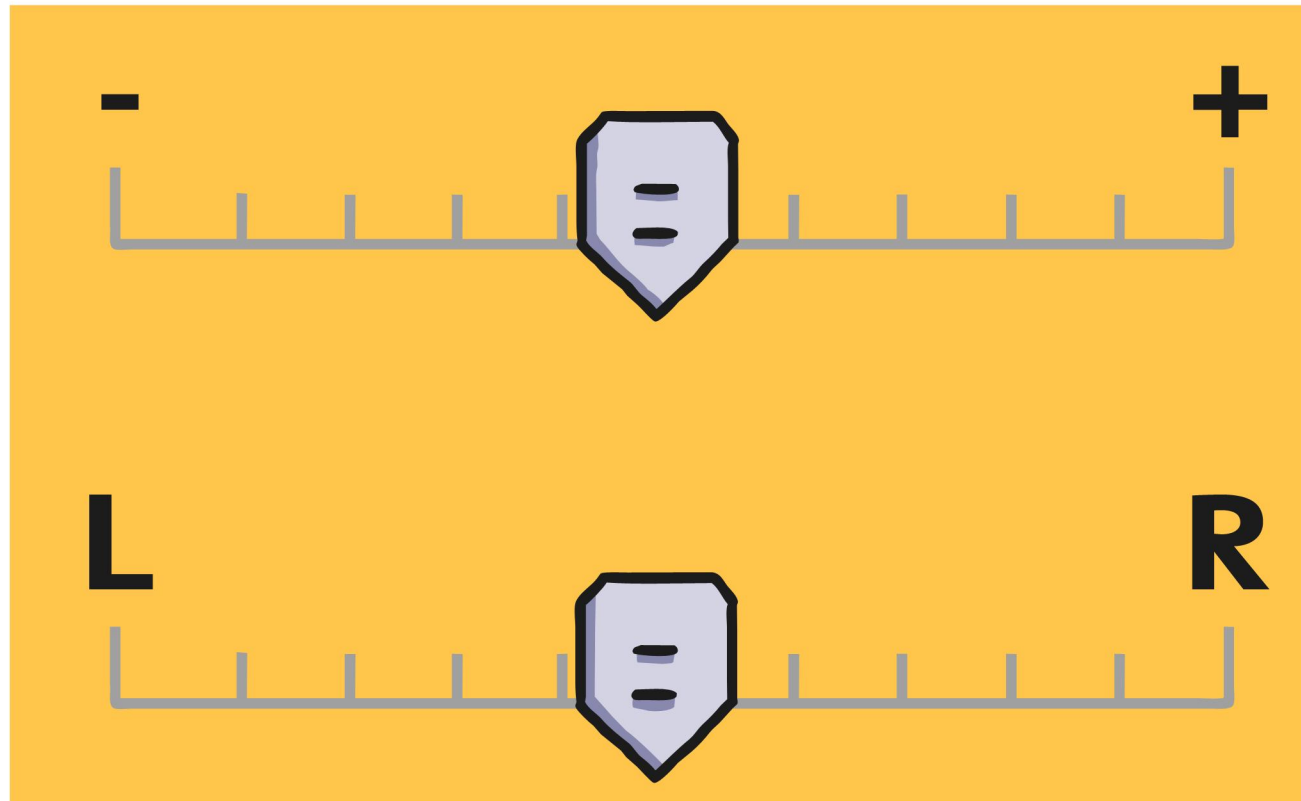

podcast



Regent Studies | www.regentstudies.com

output

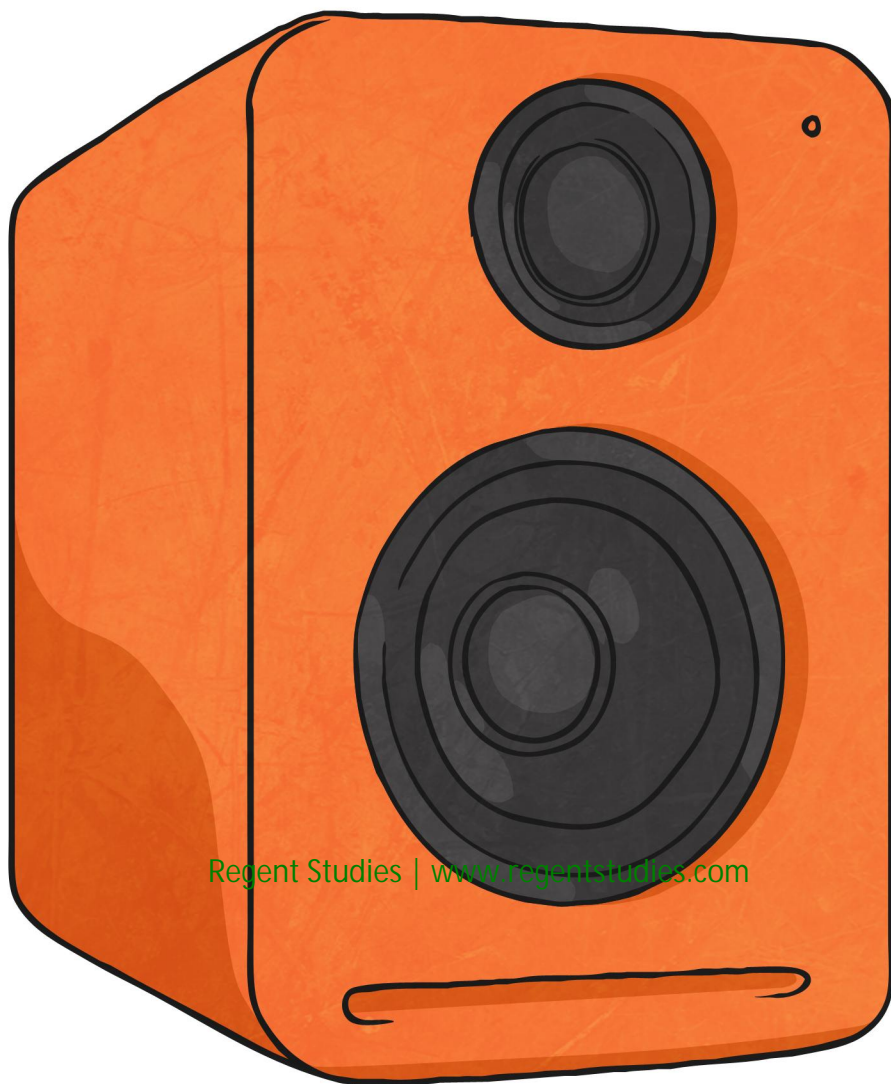

Regent Studies | www.regentstudies.com

input



Regent Studies | www.regentstudies.com

sound

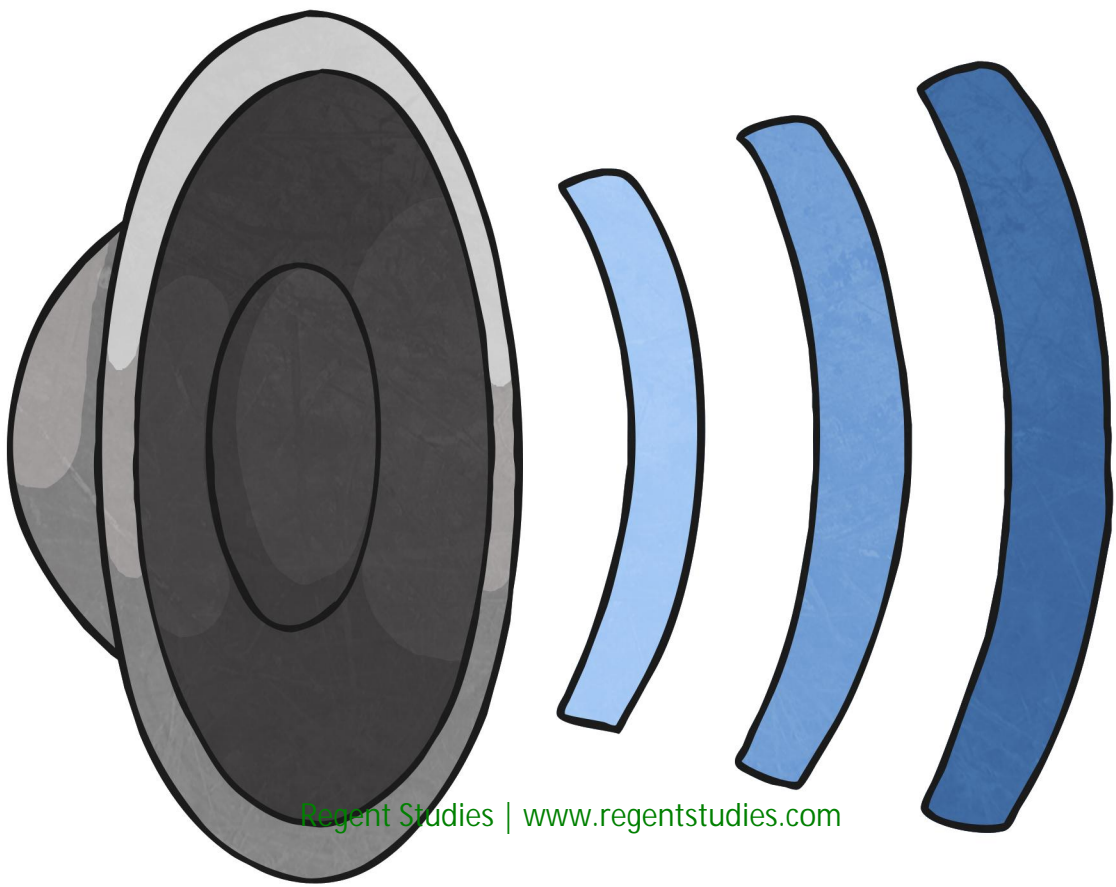

download

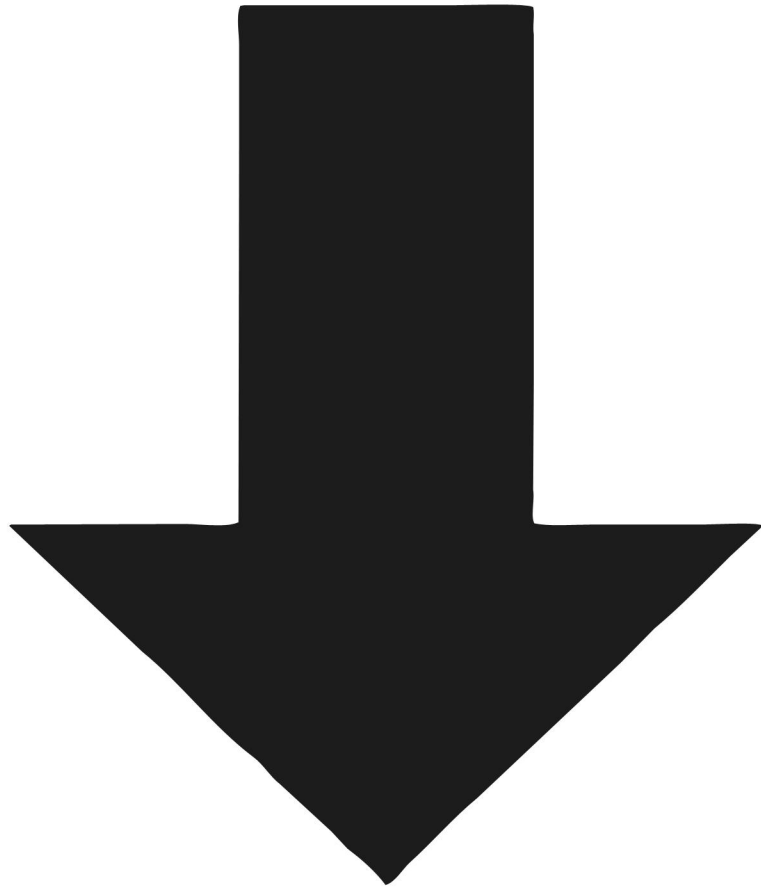

Regent Studies | www.regentstudies.com

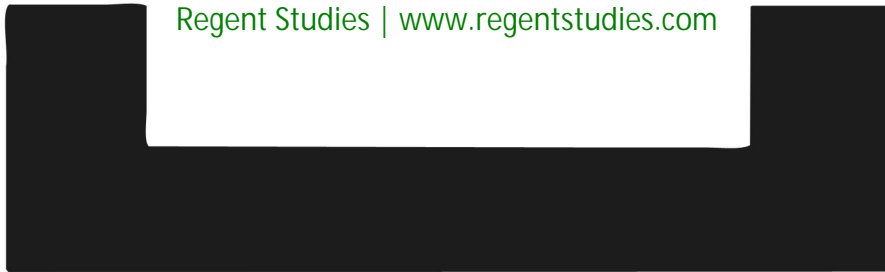

voiceover



jingle



audio

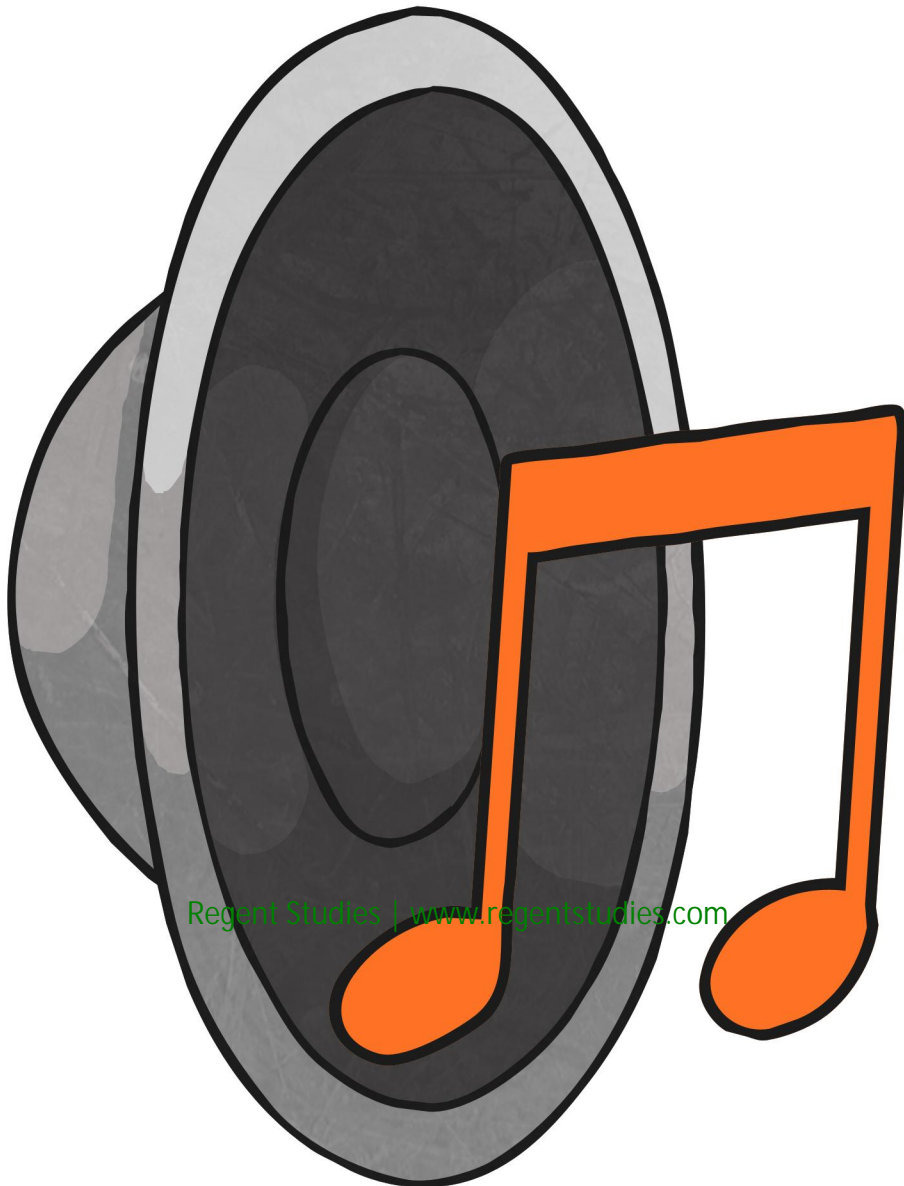

edit



backing track



Regent Studies | www.regentstudies.com

listen



Regent Studies | www.regentstudies.com

play



Regent Studies | www.regentstudies.com

stop

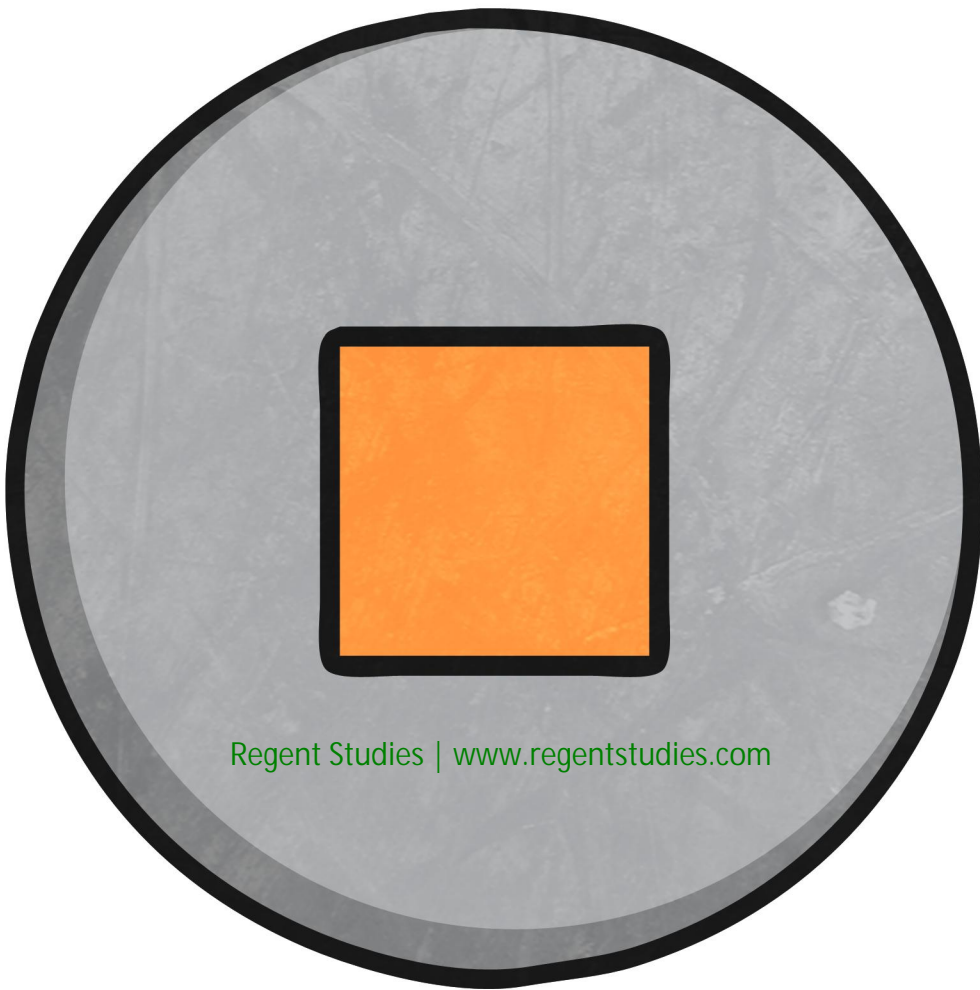

Regent Studies | www.regentstudies.com

record

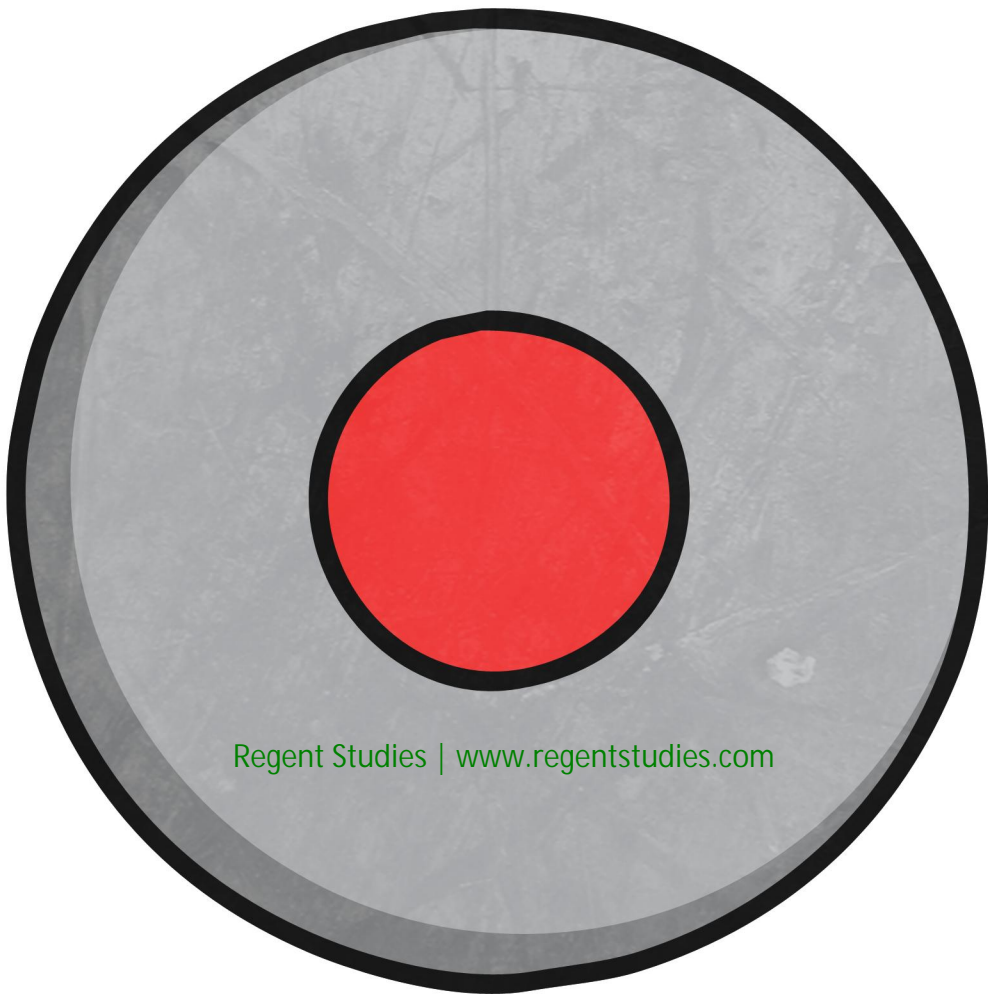

Regent Studies | www.regentstudies.com

skip



Regent Studies | www.regentstudies.com

digital content



mute

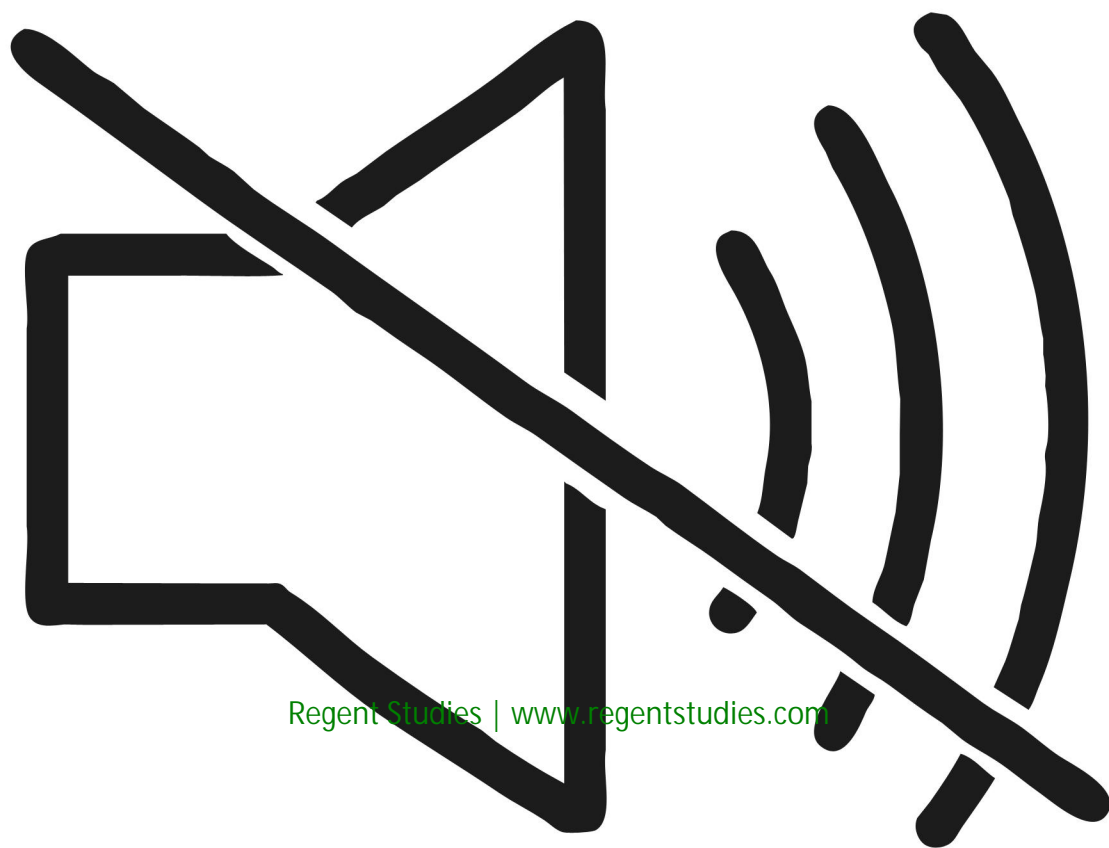

Regent Studies | www.regentstudies.com

gain

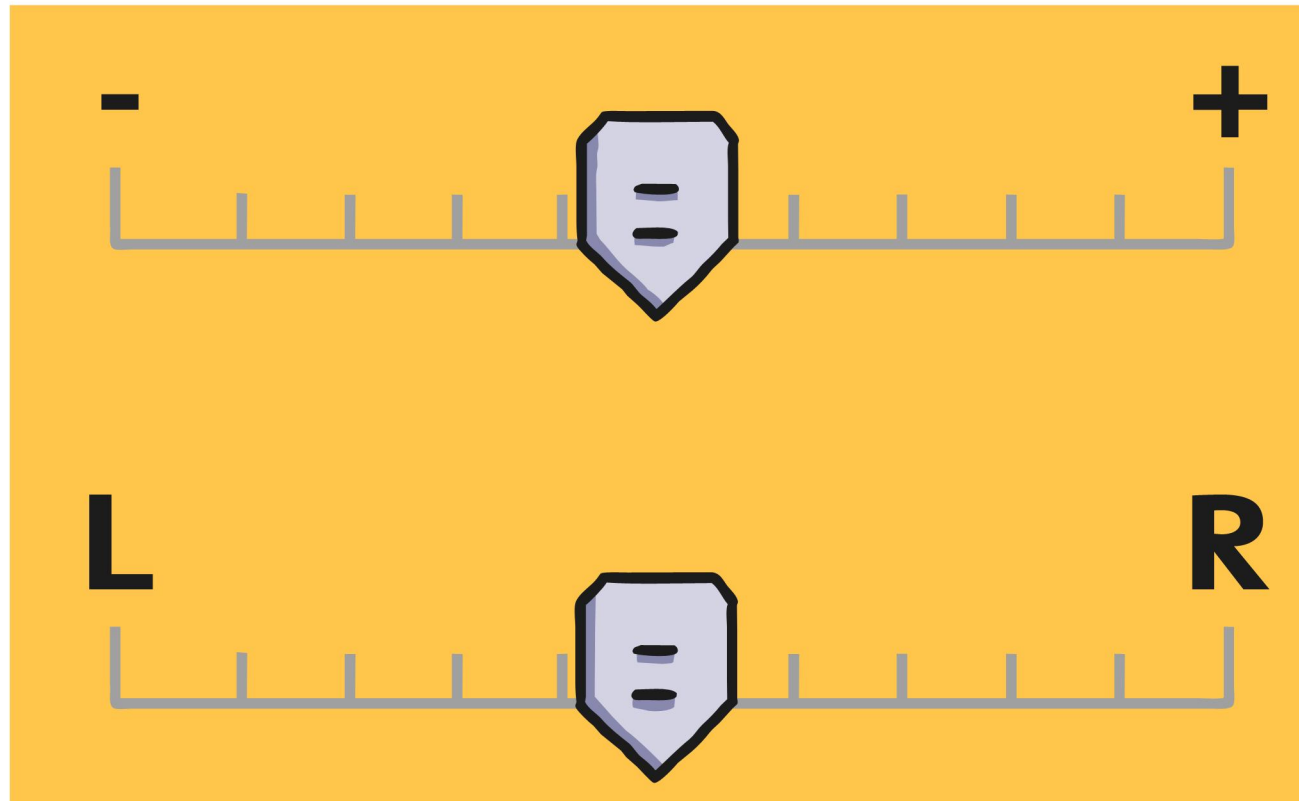

podcast



output

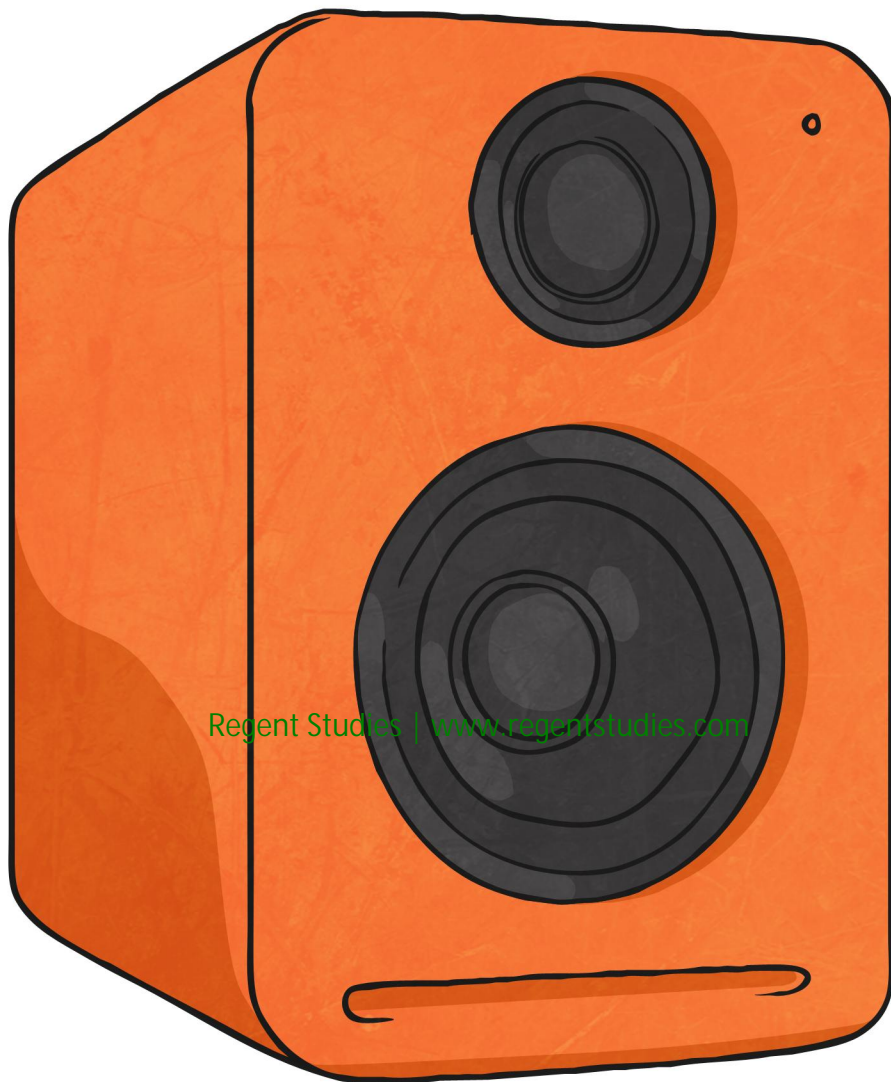

Regent Studies | www.regentstudies.com

input



Regent Studies | www.regentstudies.com

sound

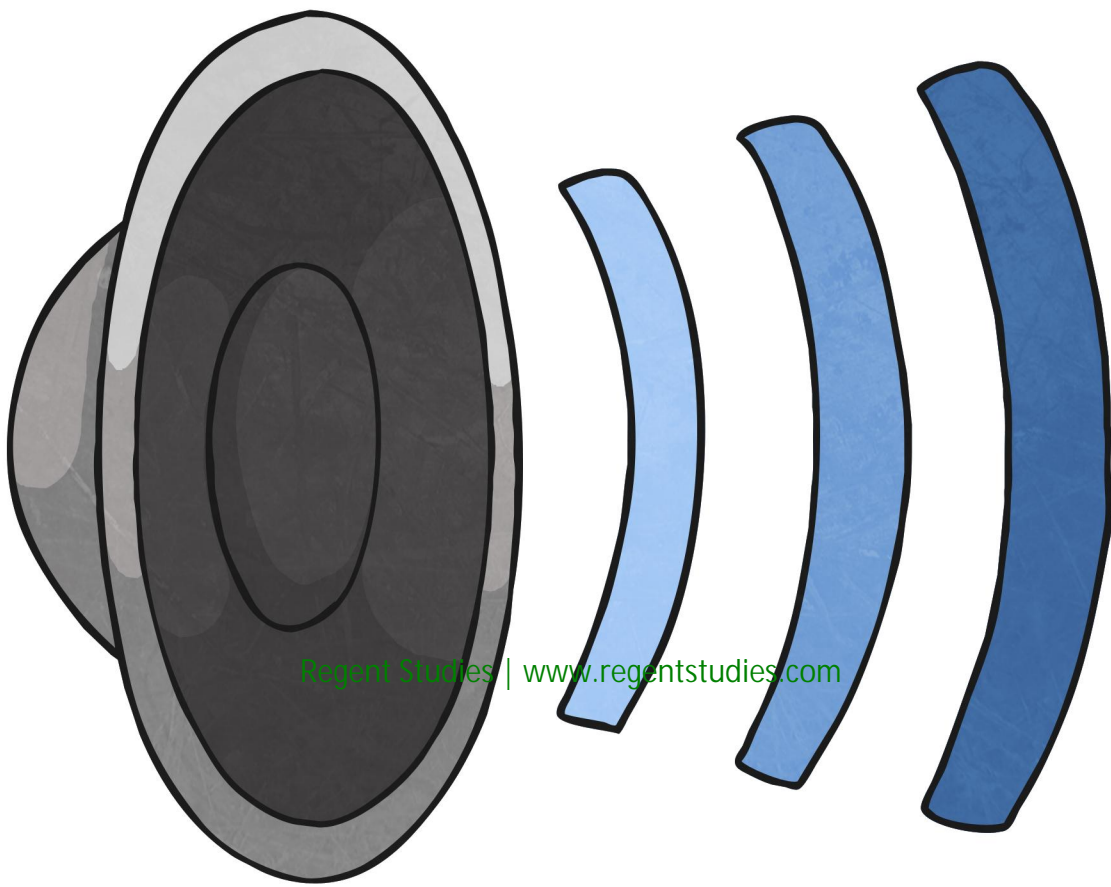

download

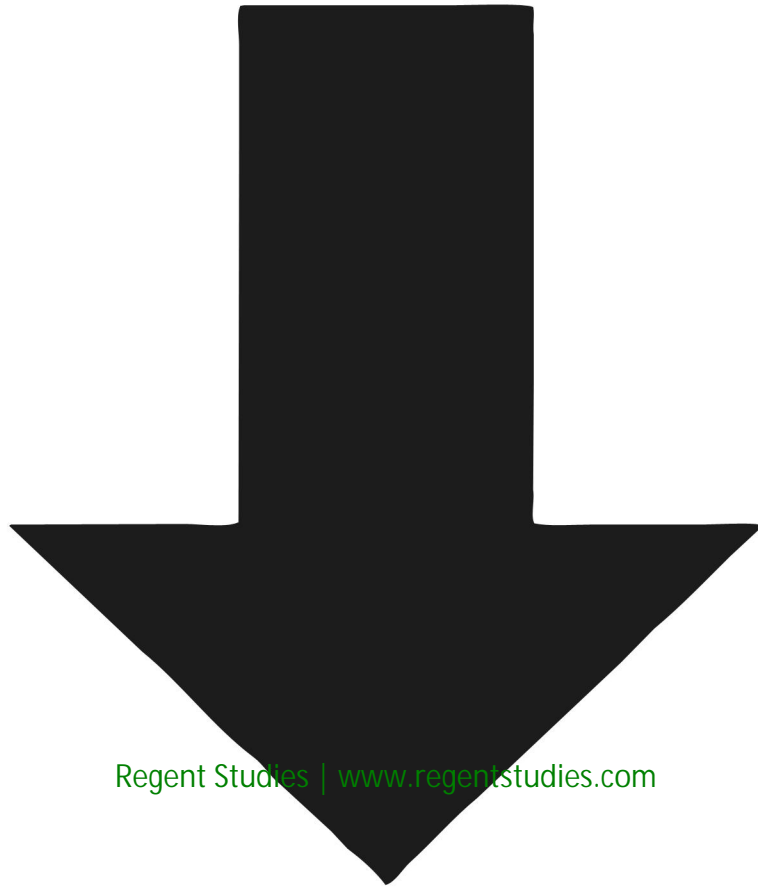

Regent Studies | www.regentstudies.com



voiceover



jingle



audio



Regent Studies | www.regentstudies.com

waveform

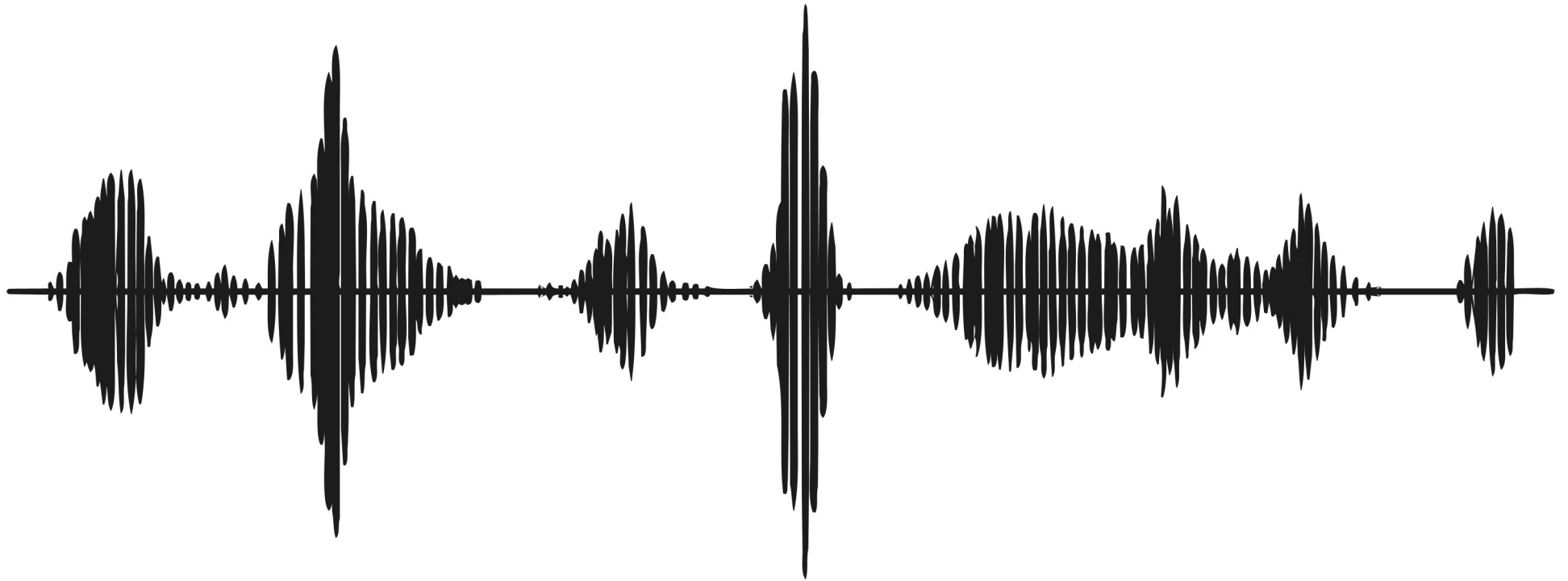

edit



Regent Studies | www.regentstudies.com

0:03:49

L R

The image displays a digital audio workstation (DAW) interface. At the top, the word "edit" is written in a large, black, sans-serif font. Below this is a waveform editor showing two channels of audio. The waveform is primarily orange, but a central segment is highlighted in blue, indicating it is selected for editing. A vertical white line marks the end of the selected segment. Below the waveform is a control bar with several circular buttons: a double left arrow (stop), a red circle (record), an orange square (stop), a green right arrow (play), and a double right arrow (next). To the right of these buttons is a digital time display showing "0:03:49". Further right are two volume sliders, one for the left channel (L) and one for the right channel (R), both with a central knob and a scale from minus to plus.

backing track



listen

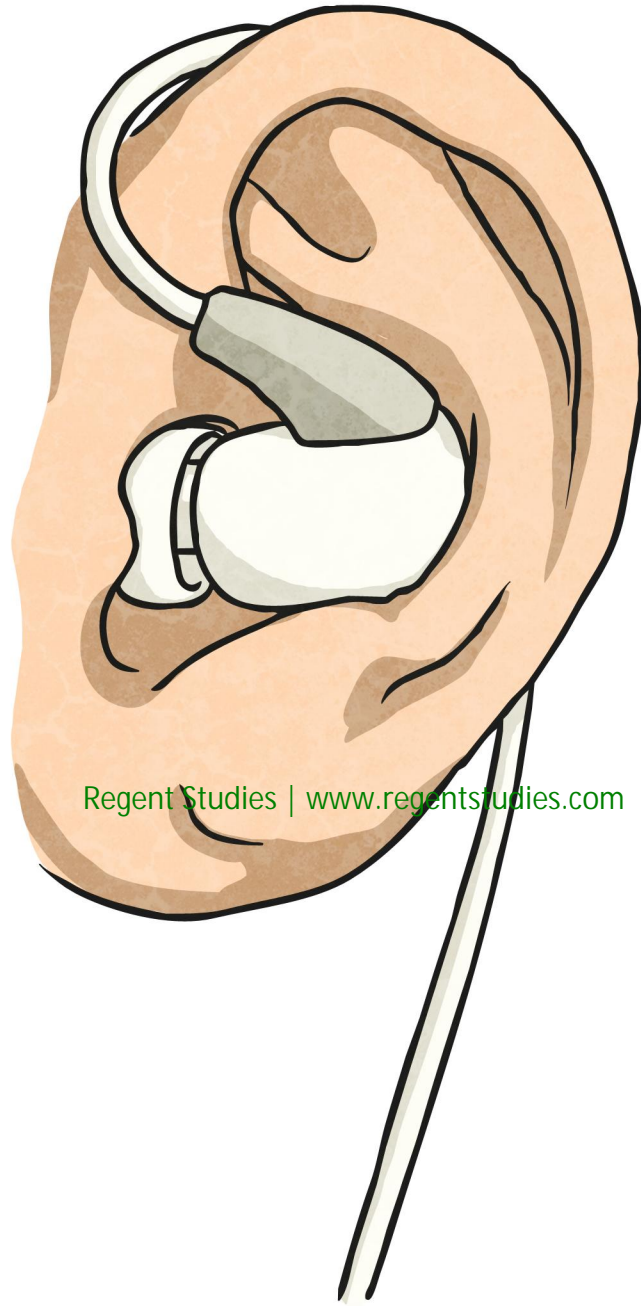

Regent Studies | www.regentstudies.com

play

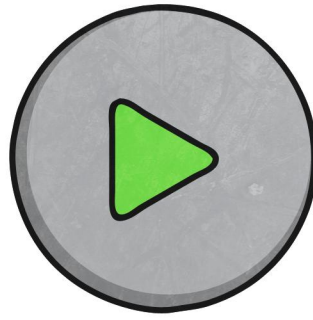

stop

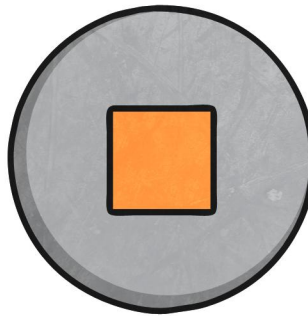

record

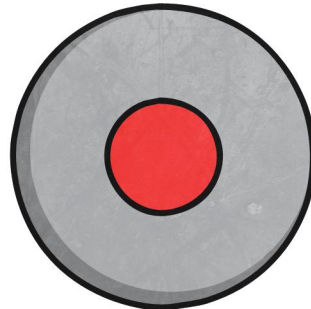

skip



digital content



mute

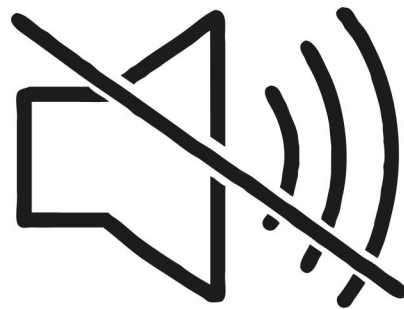

gain

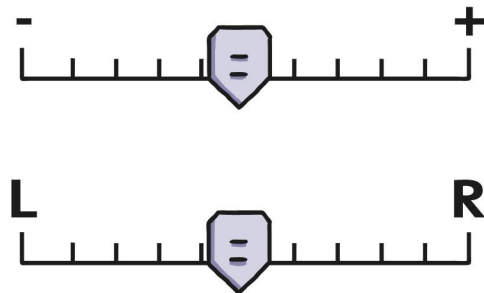

edit



podcast



output



input



backing track



sound

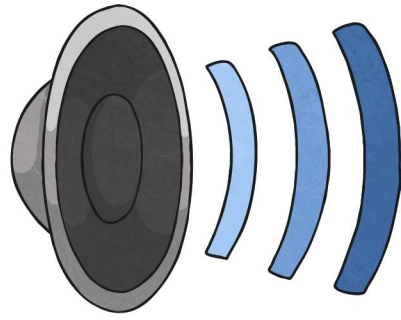

download

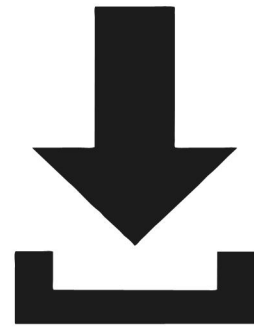

jingle



rehearse

audio



voiceover



listen



waveform



play

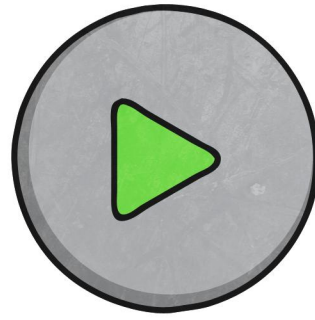

stop

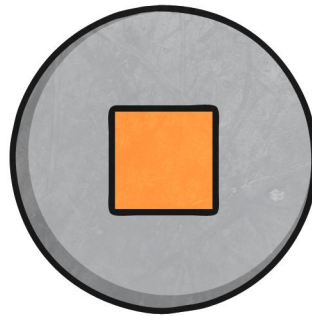

record

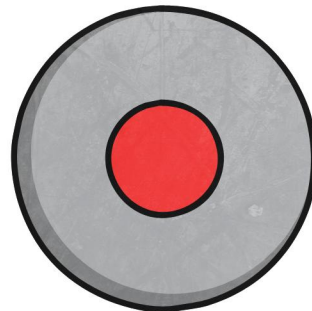

skip



digital content



mute



gain

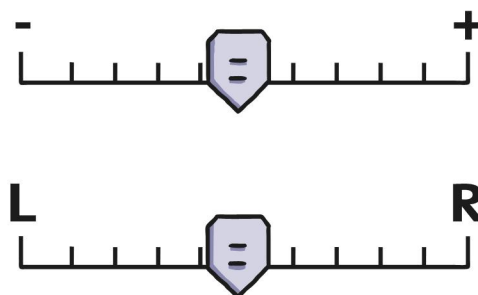

edit



podcast



output



input



backing track



sound

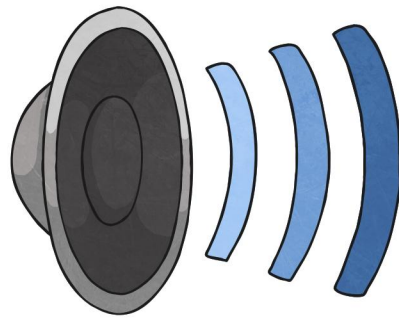

download

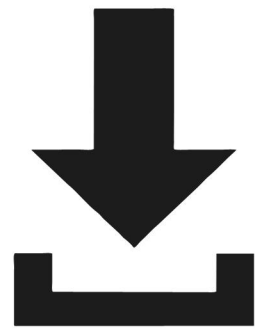

jingle



rehearse

audio



voiceover



listen



waveform

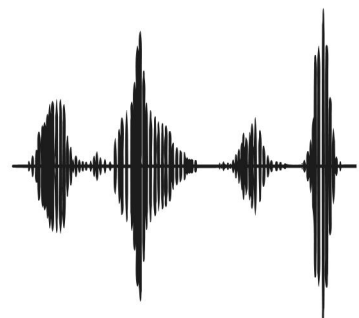

Radio Station



play

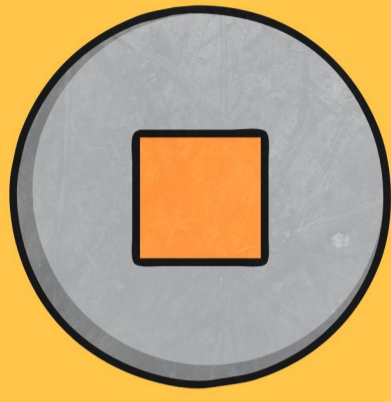

stop

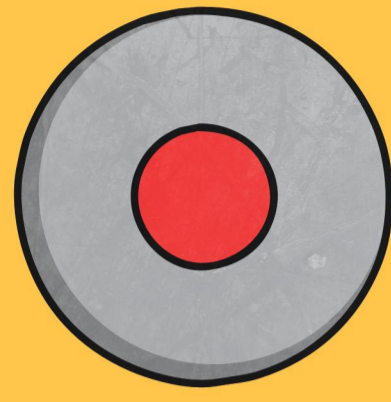

record



skip



digital content



mute

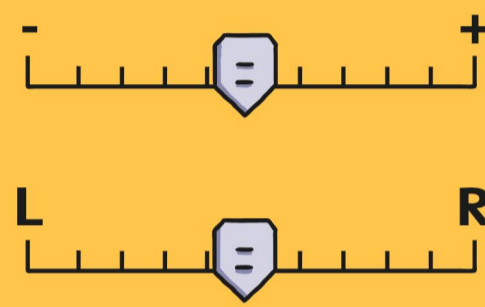

gain



podcast



output



input

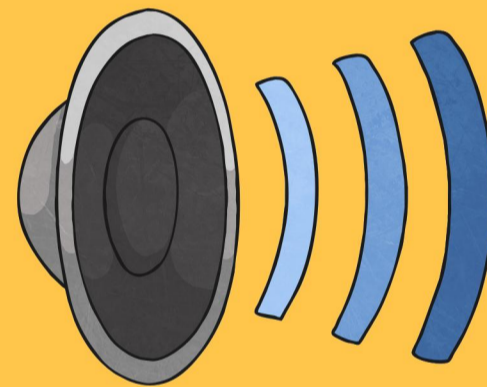

sound

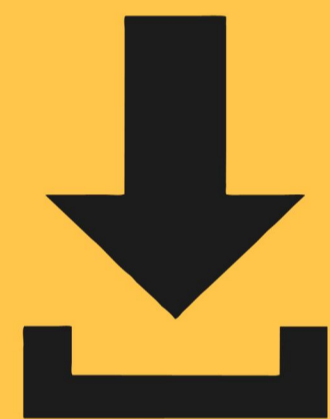

download



voiceover



jingle



audio



waveform



edit

Radio Station



play

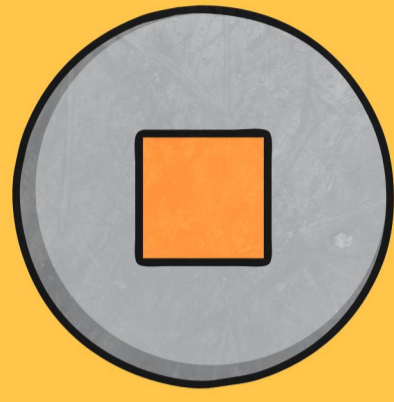

stop

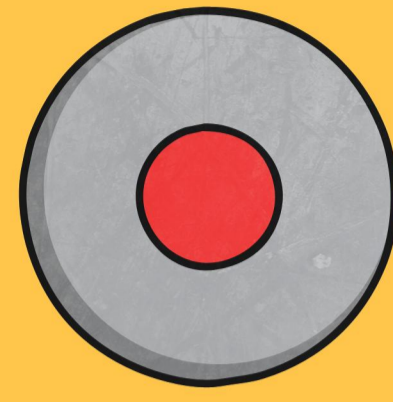

record



skip



digital content



mute

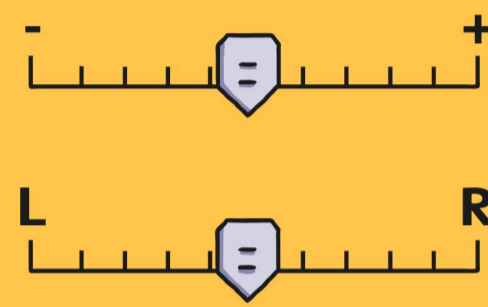

gain



podcast



output



input

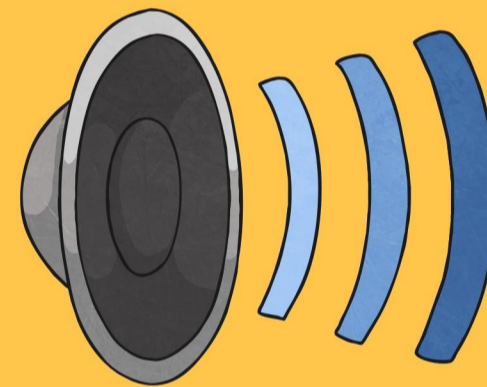

sound

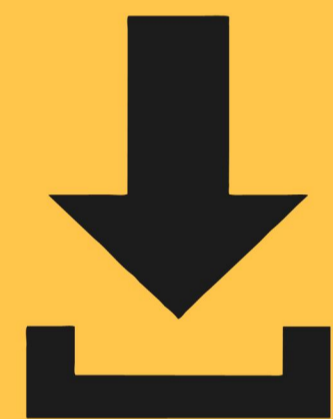

download



voiceover



jingle



audio



waveform



edit

Radio Station

i s o i e s o u n d n b
n t a p o d c a s t v r
p o e s m w f e o q i t
u p n a u d i o h k o u
t r l c k a o h j r e p
c c a i g l g a i e u t
y d h s b a l j d c w u
c a j k f s i h f o h o
t k l i c b s n s r d p
e e s p s h e r s d r a
c c f f a h s o g a u n
u m u t e f i e d i t q

audio	sound
record	input
edit	output
play	mute
stop	gain
skip	podcast

Radio Station

b g d r r e c o r d a p
a p o d c a s t u h v h
c e d a o l n w o d o i
k s r o l t e f s w i n
i c e p i u i r n a c p
n p h l s p s h u v e u
g p e a t t g d f e o t
t o a y e u i u c f v e
r t r k n o v j a o e o
a s s j i n g l e r r d
c l e f b s o a o m p i
k v s o u n d m e d i t

backing track	rehearse
waveform	voiceover
sound	download
audio	listen
record	jingle
input	edit
output	play
podcast	stop

Radio Station

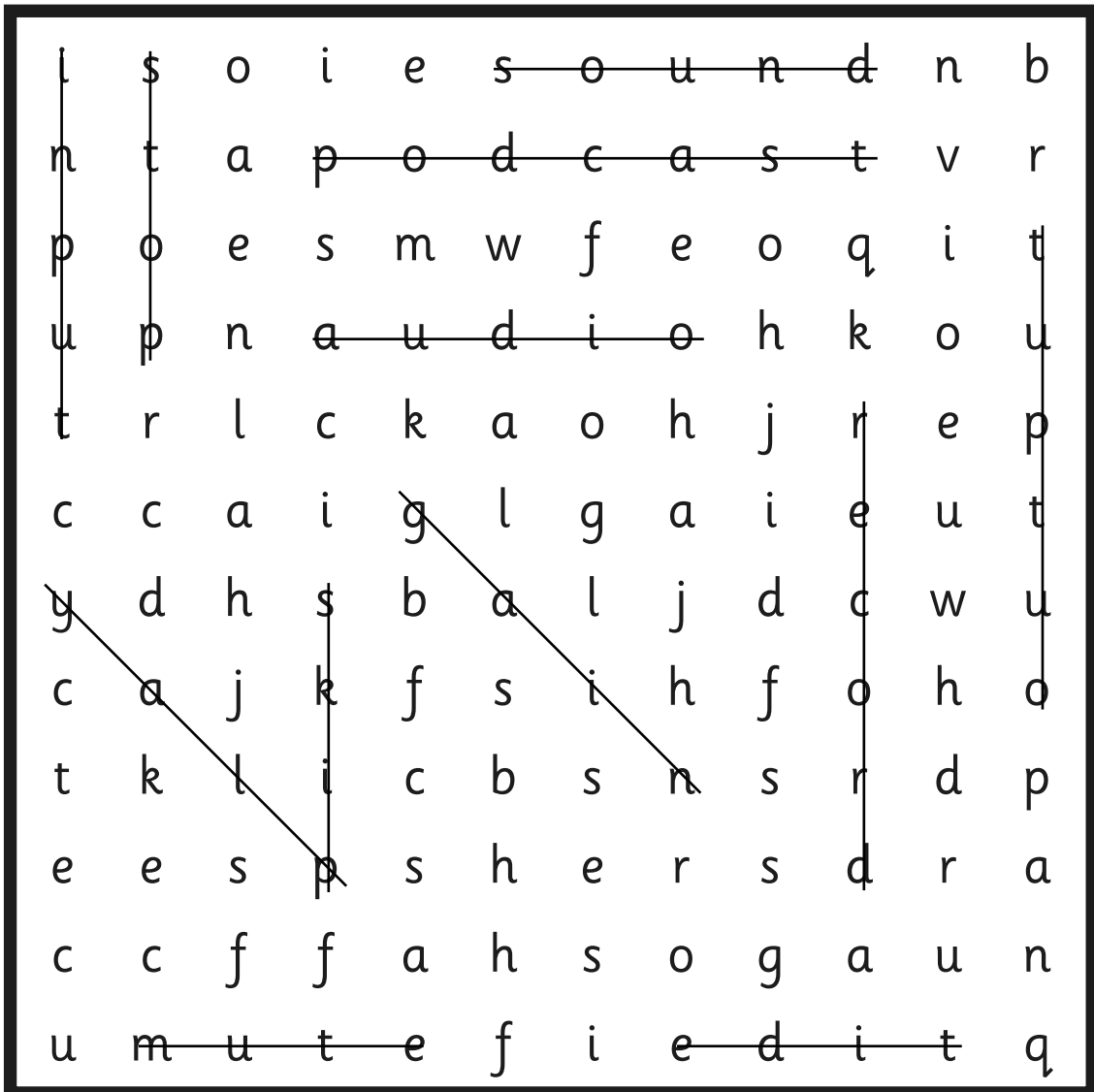

audio

record

edit

play

stop

skip

sound

input

output

mute

gain

podcast

Radio Station

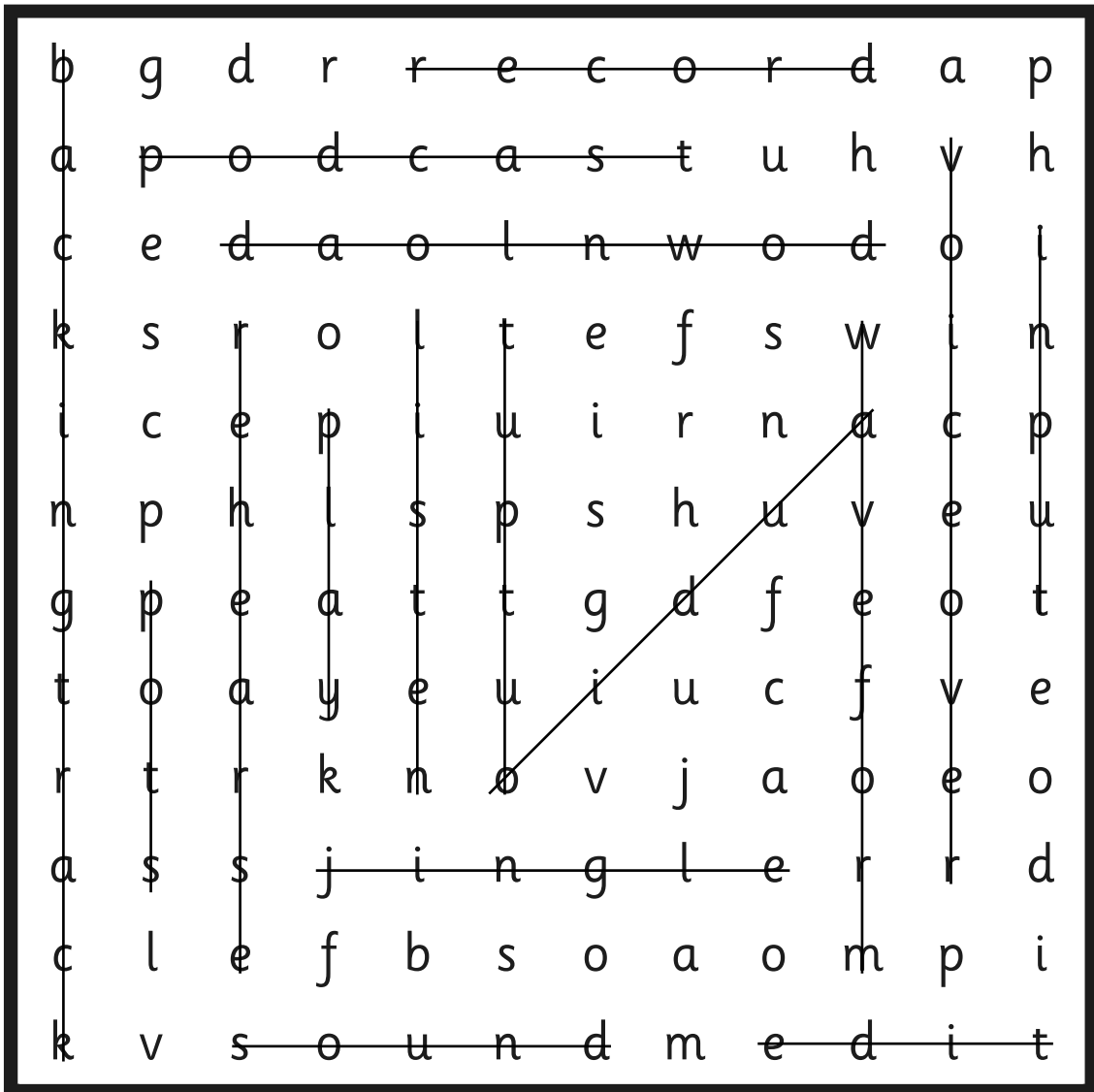

backing track

waveform

sound

audio

record

input

output

podcast

rehearse

voiceover

download

listen

jingle

edit

play

stop

Radio Station

i s o i e s o u n d n b
n t a p o d c a s t v r
p o e s m w f e o q i t
u p n a u d i o h k o u
t r l c k a o h j r e p
c c a i g l g a i e u t
y d h s b a l j d c w u
c a j k f s i h f o h o
t k l i c b s n s r d p
e e s p s h e r s d r a
c c f f a h s o g a u n
u m u t e f i e d i t q

audio
record
edit
play
stop
skip

sound
input
output
mute
gain
podcast

Radio Station

b g d r r e c o r d a p
a p o d c a s t u h v h
c e d a o l n w o d o i
k s r o l t e f s w i n
i c e p i u i r n a c p
n p h l s p s h u v e u
g p e a t t g d f e o t
t o a y e u i u c f v e
r t r k n o v j a o e o
a s s j i n g l e r r d
c l e f b s o a o m p i
k v s o u n d m e d i t

backing track

waveform

sound

audio

record

input

output

podcast

rehearse

voiceover

download

listen

jingle

edit

play

stop



Radio Station

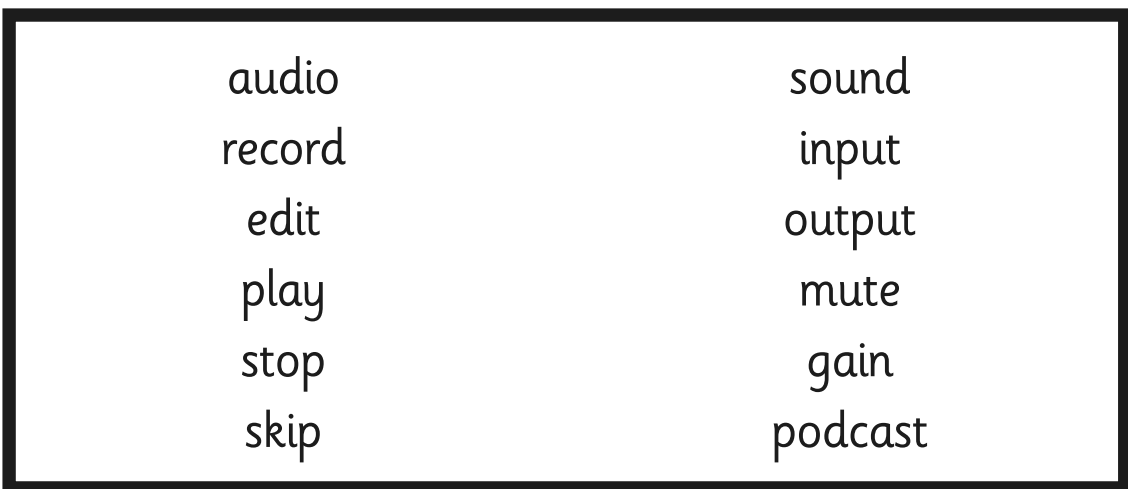
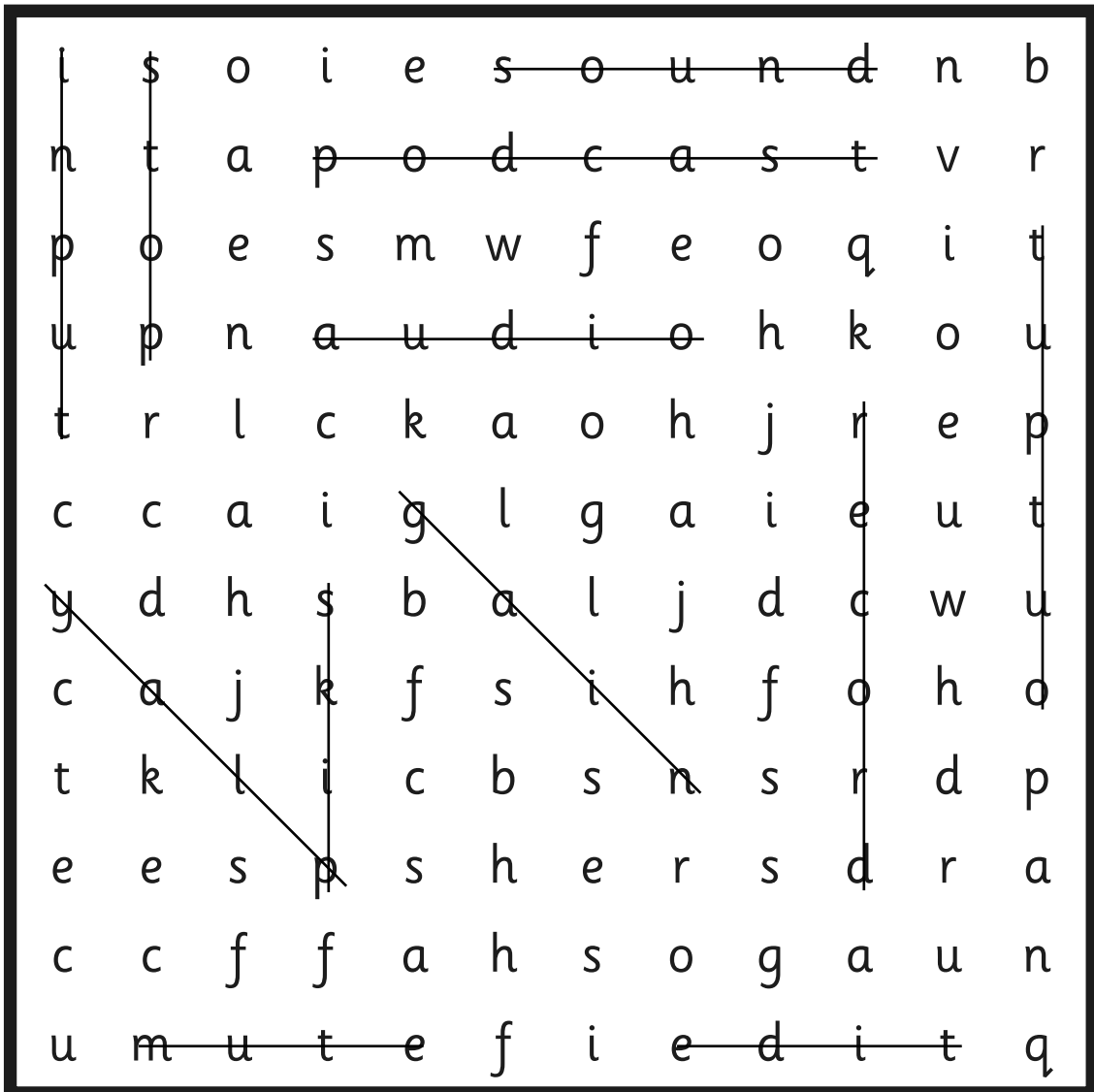

Radio Station

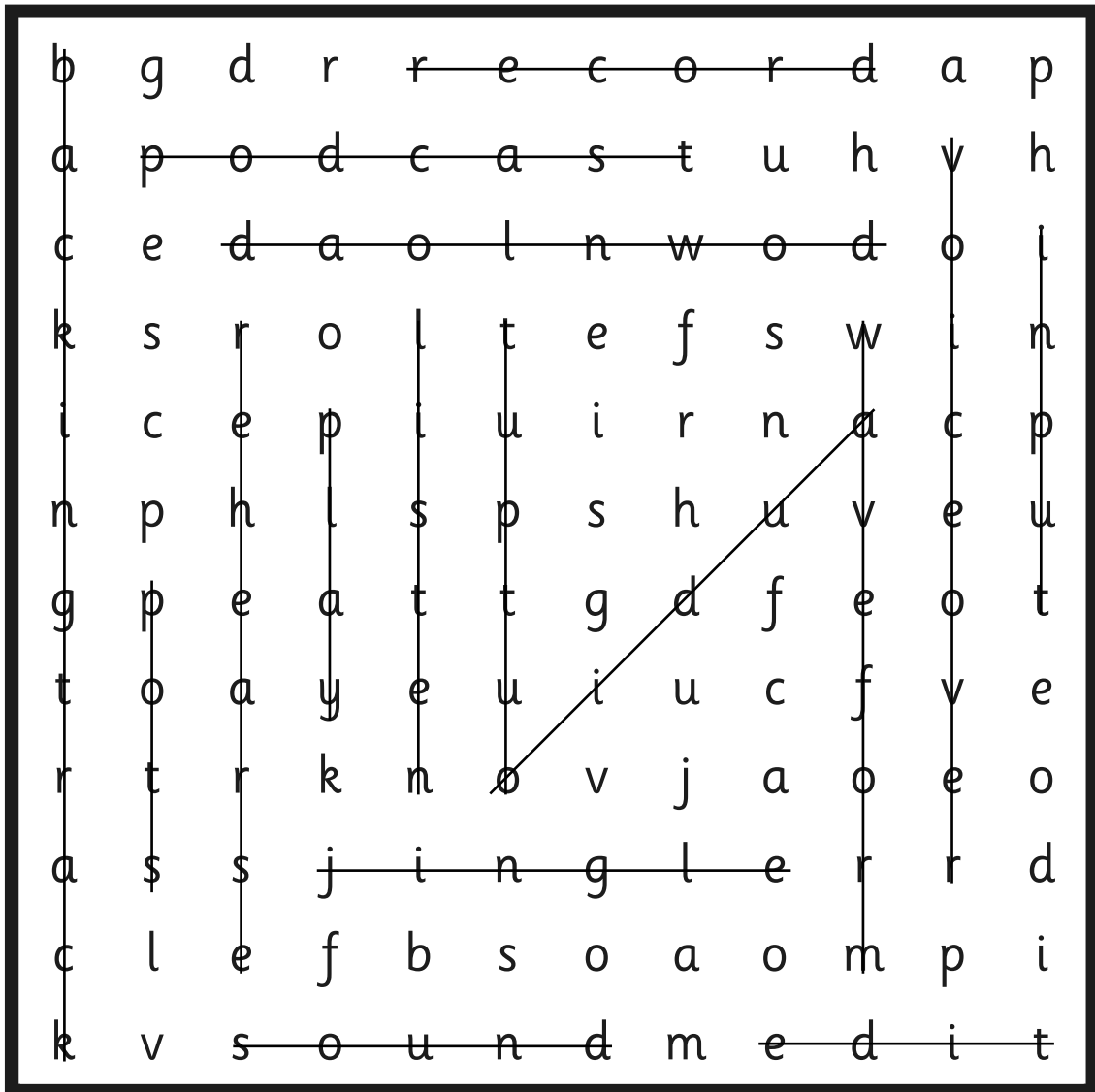

backing track	rehearse
waveform	voiceover
sound	download
audio	listen
record	jingle
input	edit
output	play
podcast	stop

Insert text here



Insert text here

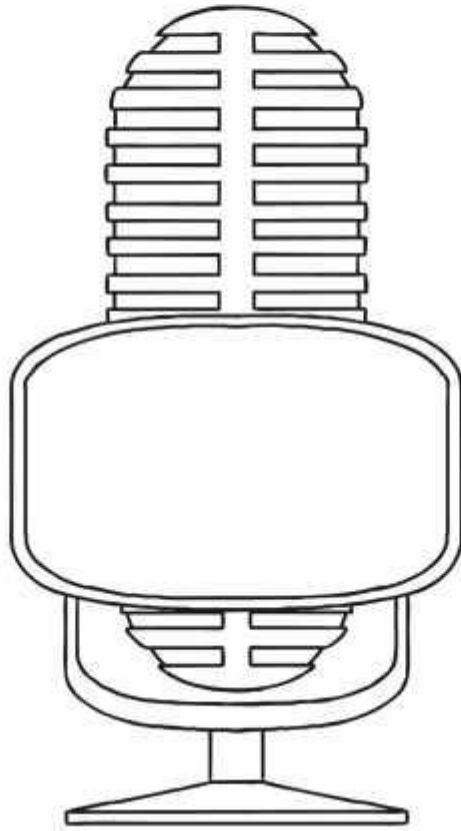

Insert text here

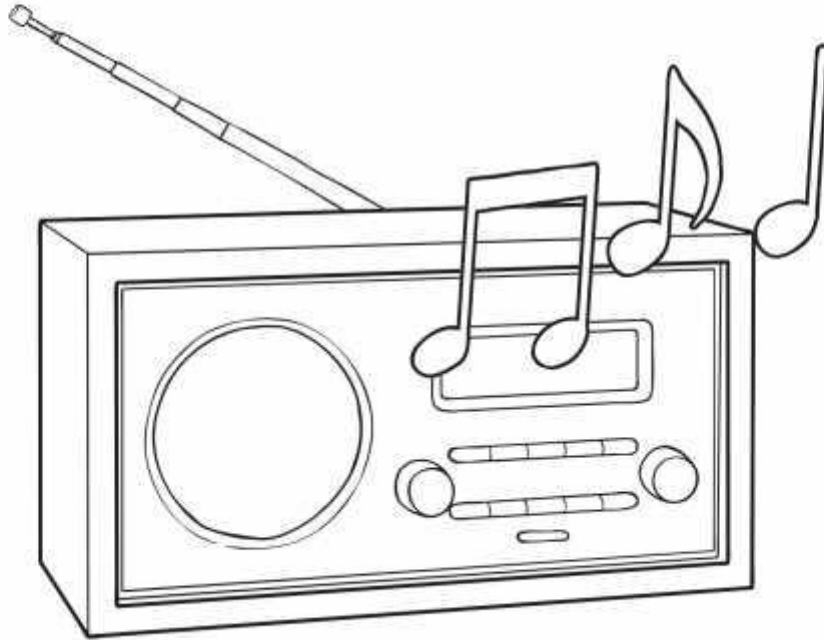

Insert text here



Insert text here



Insert text here

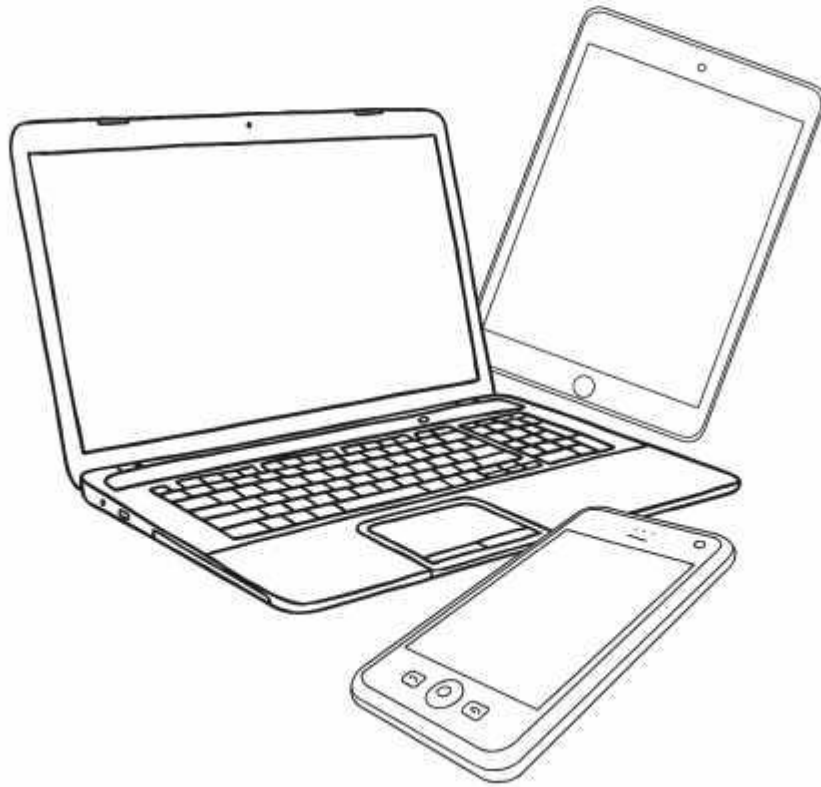

Insert text here





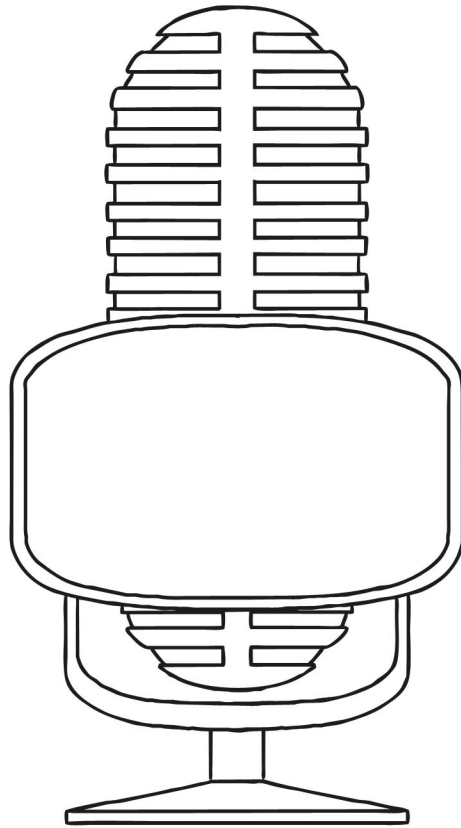

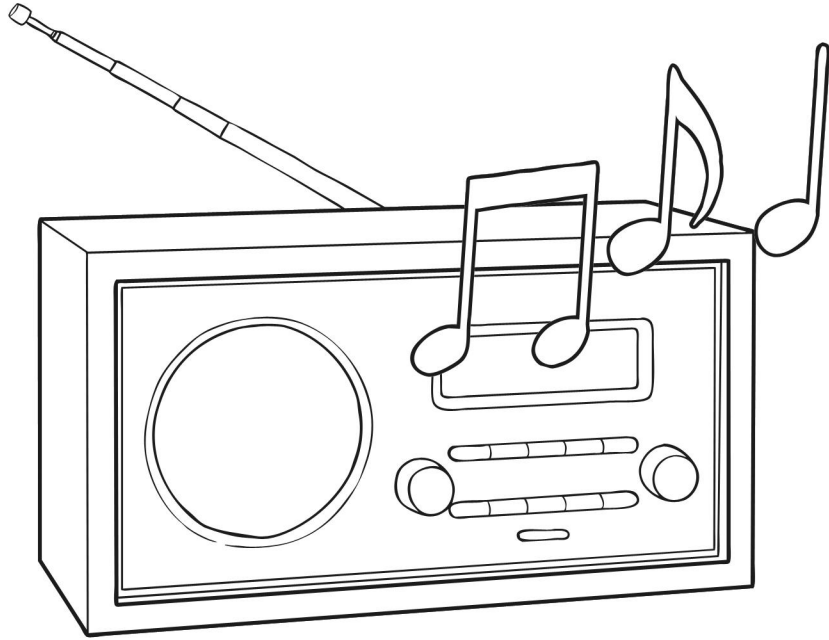





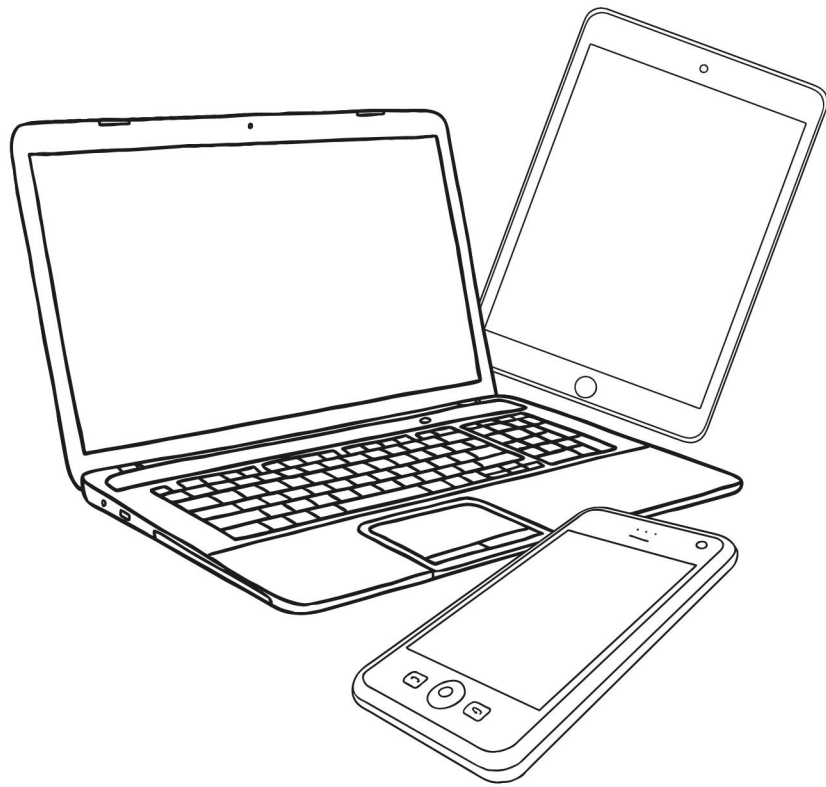





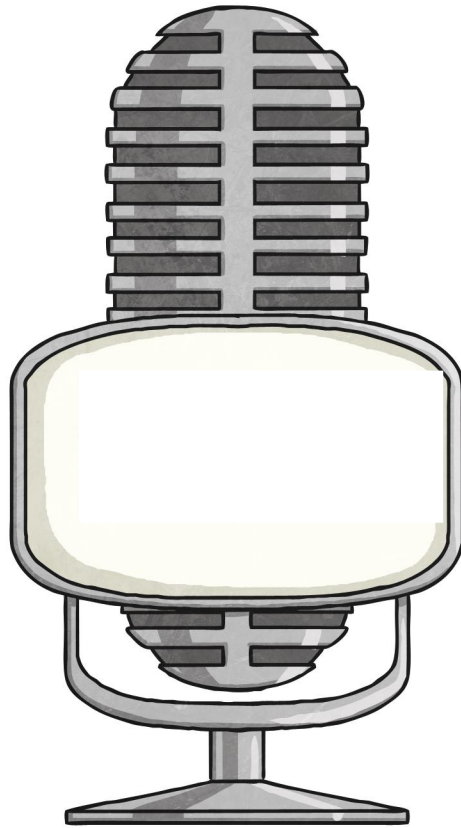











Insert text here



Insert text here

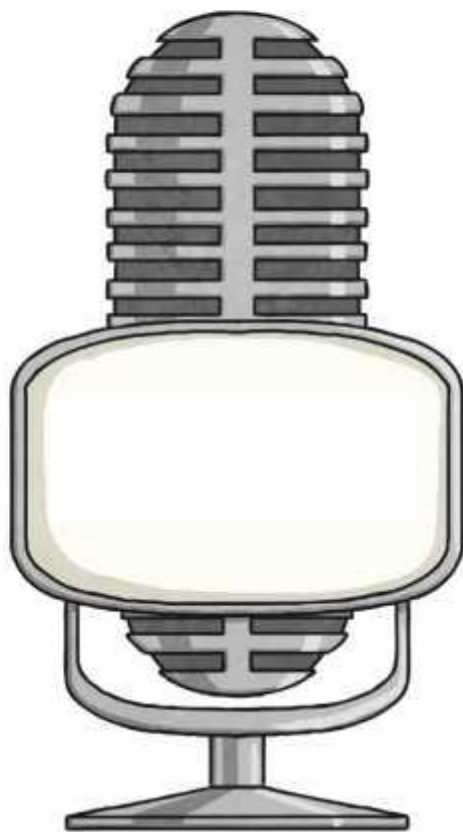

Insert text here



Insert text here



Insert text here



Insert text here



Insert text here





